

**ARCHITECTURAL FRONT PLATE INSTALLATION MANUAL**  
**ClassMate® and SchoolMate®**  
**Models CMD/CMP/CMS and SMW/SMG**

**Figure 1.1 - Architectural Front Plate**

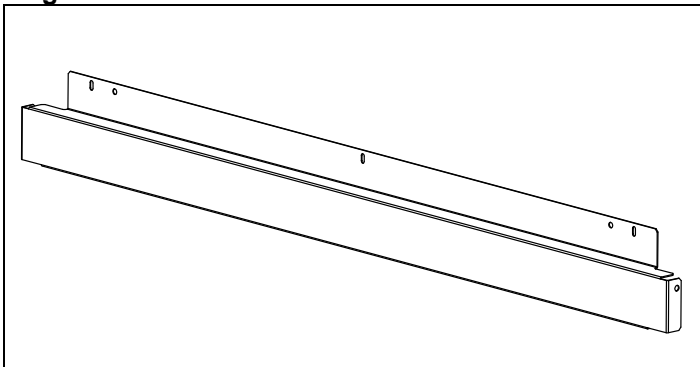

**Figure 1.2 – Remove Screws from Unit Casing**

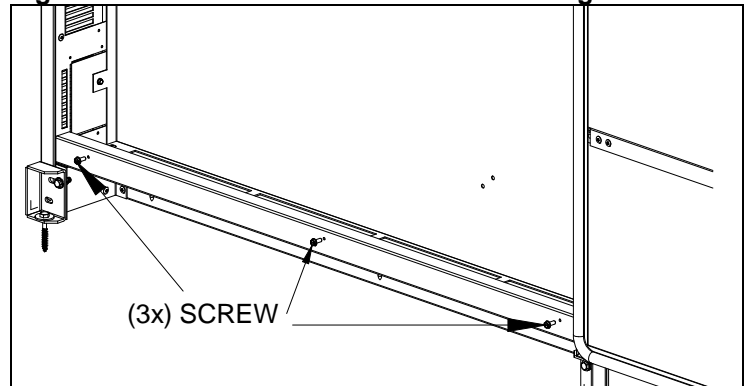

**IMPORTANT**

1. The use of this manual is specifically intended for a qualified installation and service agency. A qualified installation and service agency must perform all installation and service of these appliances.
2. The unit must be fully installed per the Installation and Service Manual before attaching the front plate.
3. These instructions must also be used in conjunction with the Installation and Service Manual originally shipped with the appliance, in addition to any other accompanying component supplier literature.

**INSTALLATION**

The instructions detailed below are for the installation of an architectural front plate (see Figure 1.1) to ensure a smooth and finished front exterior of the unit. The front plate is shipped loose for field installation and is located inside the cabinet casing.

1. Check to be sure unit is installed per the Installation and Service Manual.
2. Open the cabinet door to access (3) factory installed screws to be used to attach the front plate to the casing. The screws are located near the bottom of the unit casing, behind where the bottom of the door closes. See Figure 1.2. Remove the screws from the unit casing.

3. Insert the front plate into the cavity below the unit door. Align the (3) oval hole openings on the front plate with the (3) screw holes on the unit casing. See Figure 1.3. The oval clearance holes on the front plate allow for adjustment so the front plate can be flush with the floor.
4. Using the screws removed from step 2, attach the front plate to the unit casing.

**Figure 1.3 – Attach Front Plate to Unit Casing**

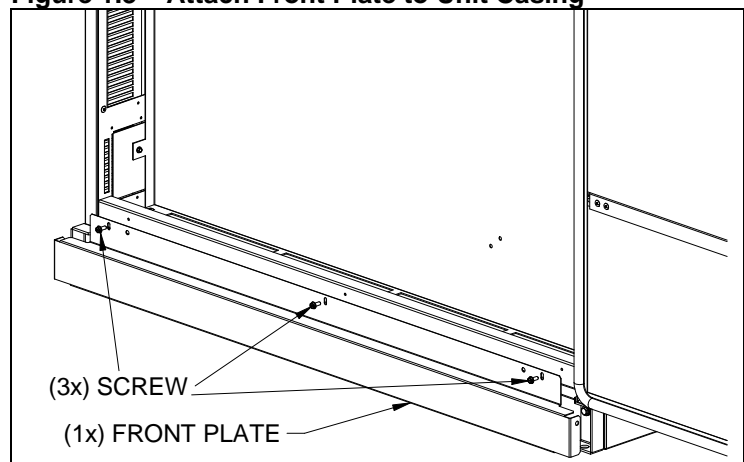

**Modine Manufacturing Company**

1500 DeKoven Avenue

Racine, WI 53403

Phone 1.866.823.1631

www.modinevac.com