

SELECTION AND INSTALLATION INSTRUCTIONS

conversion from natural gas to propane gas and high altitude operation models MT, RT



! WARNING

This conversion kit shall be installed by a qualified service agency in accordance with the manufacturer's instructions and all applicable codes and requirements of the authority having jurisdiction. If the information in these instructions is not followed exactly, a fire or explosion may result causing property damage, personal injury or loss of life. The qualified service agency performing this work assumes responsibility for the proper conversion of this appliance with this kit.

- The following field-conversions are described in this manual.
- Burner conversion from natural gas to propane gas operation (0-2000 feet elevation)
 - Burner conversion from natural gas or propane gas to high altitude operation (over 2000 feet elevation)

For Units being Converted from Natural Gas to Propane Gas at High Altitude Concurrently

IMPORTANT

For converting a unit from natural gas to propane gas at high altitude, both a propane conversion kit and a propane high altitude kit must be used.

! AVERTISSEMENT

Cet ensemble de conversion ne doit être installé que par le représentant d'un organisme qualifié et conformément aux instructions du fabricant et à tous les codes et exigences applicables de l'autorité compétente. Quiconque ne respecte pas à la lettre les instructions dans le présent manuel risque de déclencher un incendie ou une explosion entraînant des dommages matériels, des lésions corporelles ou la perte de vies humaines. L'organisme qualifié qui effectue les travaux est responsable de la conversion correcte de ce générateur d'air chaud à l'aide de cet ensemble.

For this conversion, two kits are required: one from Table 2.1 and one from Table 5.2. Both kits utilize this same manual for installation instructions. Follow the propane conversion instructions beginning on page 2 in this manual, using the orifices from the high altitude kit instead of the orifices included in the propane conversion kit.

For Units Being Converted to High Altitude Operation

Gas-fired equipment ratings in the United States are certified for elevations above 2000 feet to meet ANSI Z223.1, which requires ratings to be reduced 4% for each 1000 feet above sea level. Certification in Canada requires ratings to be reduced 10% for elevations above 2000 feet. All of the high altitude kits described in this manual comply with these requirements.

To accommodate high altitude operation (over 2000 feet elevation), the units must be converted by changing gas orifices as explained in this manual.

All gas-fired products produced by Modine Manufacturing Company are rated at 600 feet above sea level using gas values of either 1040 Btu/ft³ for natural gas or 2500 Btu/ft³ for propane gas. Since gas values vary from location to location, be sure to account for the local gas value when sizing and selecting these products.

IMPORTANT

This kit must be used in conjunction with literature number 9-500 or AIR9-500, latest revision, unit installation and service manual.

Table of Contents

Page(s)	
Model Identification	2
Natural Gas to Propane Gas Conversion (0-2000 ft.)	2-4
High Altitude Conversion (over 2000 ft.)	5
Check-Out Procedure	6

MODEL IDENTIFICATION / NATURAL GAS TO PROPANE GAS CONVERSION

Identifying the Model, MBH Input, and Control Code

Figure 2.1 explains the unit model number found on the unit's serial plate. Markings pertinent to verifying correct application of the conversion kits are identified and explained in detail. All of the following prerequisites must be satisfied before the unit is deemed convertible.

1. The first two characters in the model number must either be MT or RT.
2. The MBH Input must either be 30, 60, 90, 120, or 160.
3. The Control Code must be as follows, depending on the type of kit.
 - a. 47, 48, or 27 for natural gas to propane gas conversion (0-2000 feet)
 - b. 97, 75, 67 for propane conversion to high altitude (over 2000 feet.)
 - c. 47, 48, 04, 08, or 27 for natural gas conversion to high altitude (over 2000 feet.)

Figure 2.1
Model Number Designations

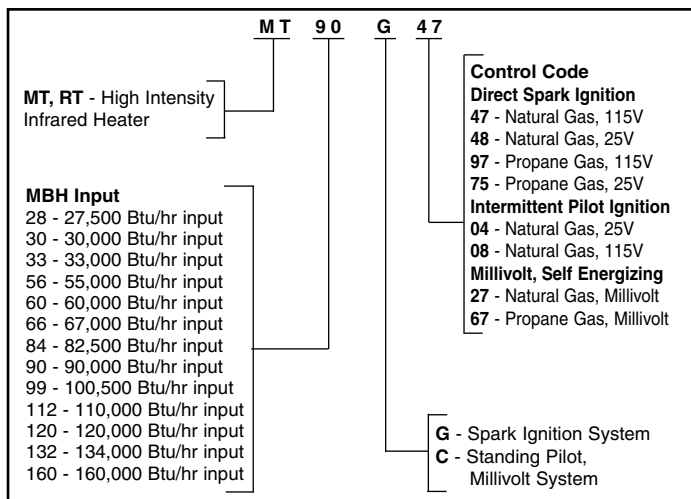

Natural Gas to Propane Gas Conversion (0-2000 feet elevation)

Control Codes 47, 48, or 27

Selection of the Proper Kit

Referring to the model number on the unit serial plate, select the appropriate kit from Table 2.1.

Example: To convert an MT 90 G 47 to propane gas operation, select Item Code #35932.

Table 2.1
Natural Gas to Propane Gas Conversion Kit Selection Guide and Parts List

Convertible Control Codes: 47, 48, 27

Description	Model Size				
	30	60	90	120	160
Kit Item Code	35930	35931	35932	35933	35934
Kit Part Number	3H35269-1	3H35269-2	3H35269-3	3H35269-4	3H35269-5
Regulator Kit for White-Rodgers 36E, 36C	92-0659	92-0659	92-0659	92-0659	92-0659
Regulator Kit for Honeywell VS820	391937	391937	391937	391937	-
Conversion Kit Rating Plate	5H73734A	5H73734A	5H73734A	5H73734A	5H73734A
Burner Orifice Size (Quantity)	52 (1)	52 (2)	52 (3)	52 (4)	49 (4)
Pilot Orifice ^①	31673	31673	31673	31673	-

^① Pilot orifice only used when converting millivolt systems (Control Code 27).

Installation of Kit

CAUTION

Gas supply shall be shut off prior to disconnecting the electrical power, before proceeding with the conversion. Failure to do so could result in fire, explosion or electrical shock.

Conversion of any unit is the responsibility of, and the risk of the person making the conversion.

General

The gas valve regulator kit contains the following.

- Cap screw (Honeywell kit)
- Adjustment screw (Honeywell kit)
- Spring
- Warning label
- Instructions

If also converting to high altitude operation during the natural gas to propane gas conversion, discard the propane burner orifice of the kit from Table 2.1. Replace it with the high altitude propane burner orifice from the appropriate kit from table 5.2.

NATURAL GAS TO PROPANE GAS CONVERSION

Control Codes 47, 48 (Direct Spark)

1. Ensure gas supply and electrical power disconnections have been made.
2. Remove main gas orifice(s). Refer to Figure 3.1.
3. Insert propane orifice into manifold assembly. Refer to Table 2.1 for correct gas orifice nipple size. Each gas orifice is stamped with the drill size as well. Verify correct size is being installed. Tighten gas orifice using a wrench and ensure that it is gas tight.
4. Modify the combination gas control to use propane gas by following the instructions in the regulator kit. Some conversion kits will have more than one regulator kit, specific to the manufacturer of the combination gas control (i.e. Honeywell, White-Rogers, etc.). Check the conversion kit parts list, Table 2.1, for application of the correct regulator kit. A second check can be made by finding the model number on the combination gas control and matching it with the correct kit. Do not attempt to substitute one regulator kit for another.
5. Discard pilot gas orifice as it is not used with direct spark ignition systems.
6. Affix the appropriate propane conversion label to the combination gas control. This label (see Figure 3.2) is supplied with the regulator conversion kit.
7. Affix the propane conversion rating plate (see Figure 3.3) adjacent to the unit's original rating plate. Be sure that all blanks on the label are completely filled in.
8. Verify that all controls and wiring have not been damaged.
9. Continue with Check-out Procedure on page 6 of this manual.

Figure 3.1
Main Gas Orifice

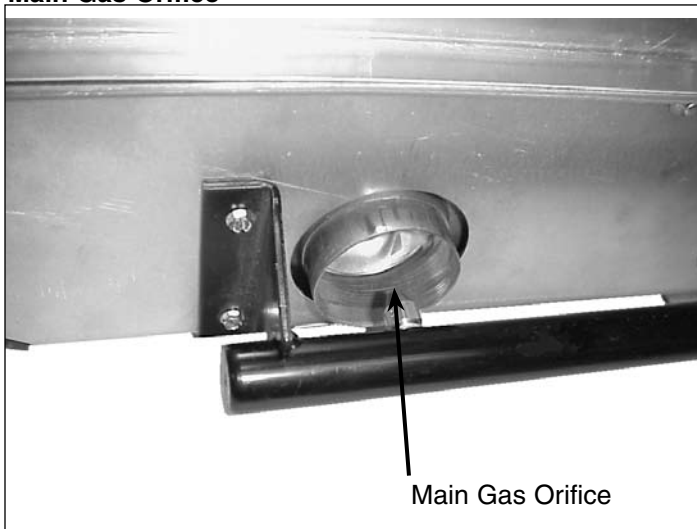

Figure 3.2
Typical Combination Gas Control Conversion Labels

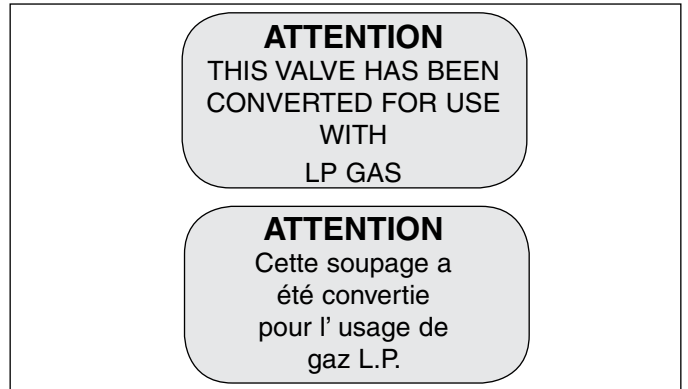

Figure 3.3
Conversion Rating Plate

**MODINE MANUFACTURING COMPANY
CONVERSION KIT RATING PLATE**

This appliance was converted on
to propane gas with kit no. _____
by: _____

which accepts the responsibility that this
conversion has been properly made. Use parts
supplied by Commercial HVAC&R Division of
Modine Manufacturing Company. Conversion to be
performed by a qualified service technician.

Appliance model number and input rating: See
existing rating plate.

Inlet gas pressure: Minimum 12" W.C.
 Maximum 14" W.C.

Manifold gas pressure: 10" W.C.

Burner orifice size: # _____ drill

Ce générateur d'air chaud a été converti le
_____ pour fonctionner au gaz propane à
l'aide de l'ensemble n° _____
par _____

(nom et adresse de l'organisme qui a effectué la
conversion), qui accepte l'entière responsabilité
de la conversion.

5H73734A

NATURAL GAS TO PROPANE GAS CONVERSION

Control Code 27 (Millivolt)

1. Disconnect the gas supply to the unit.
2. Remove main gas orifice(s). Refer to Figure 3.1.
3. Insert propane orifice into manifold assembly. Refer to Table 2.1 for correct gas orifice nipple size, which corresponds with drill size. Each gas orifice is stamped with the drill size as well. Verify correct size is being installed. Tighten gas orifice using a wrench to ensure that it is gas tight.
4. To change pilot orifice:
 1. Detach and rotate pilot assembly clear of unit allowing easy access to pilot orifice. Pilot tube may have to be loosened at gas valve to allow for rotation. Refer to Figure 4.1.
 2. Remove natural gas pilot orifice and replace with propane pilot orifice. Refer to Figure 4.2. Refer to Table 2.1 to verify proper pilot gas orifice number, which is stamped on the pilot orifice. Tighten pilot orifice with a wrench and ensure that it is gas-tight.
 3. Replace pilot assembly by rotating pilot-to-gas valve tubing. Fasten pilot assembly using a wrench and ensure that it is gas tight. Also ensure connection from pilot tube to gas valve is gas tight.
5. Modify the combination gas control regulator to use propane gas by following the instructions in the regulator kit. Some conversion kits will have more than one regulator kit, specific to the manufacturer of the combination gas control (i.e. Honeywell, White-Rogers, etc.). Check the conversion kit parts list, Table 2.1, for application of the correct regulator kit. A second check can be made by finding the model number on the combination gas control and matching it with the correct kit. Do not attempt to substitute one regulator kit for another.
6. Affix the appropriate propane conversion label (see Figure 3.2) to the combination gas control. This label is supplied with the regulator conversion kit.
7. Affix the propane conversion rating plate (see Figure 3.3) adjacent to the unit's original rating plate. Be sure that all blanks on the label are completely filled in.
8. Verify that all controls and wiring have not been damaged.
9. Continue with Check-out Procedure on page 6 of this manual.

Figure 4.1

Pilot Gas Orifice

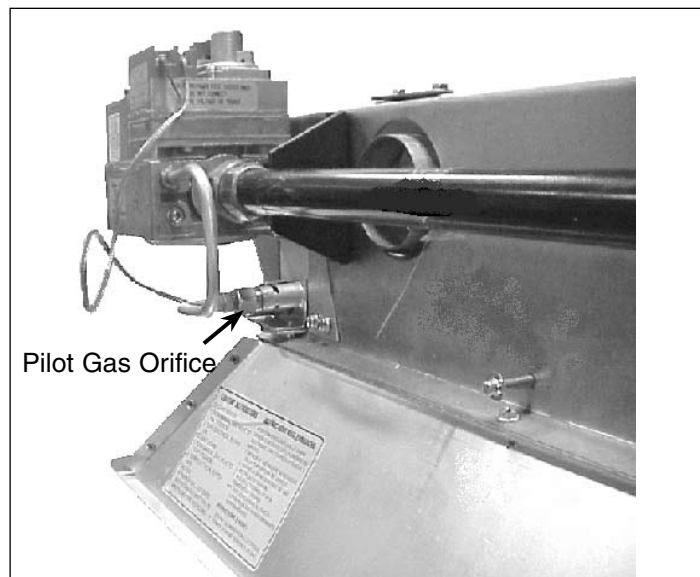
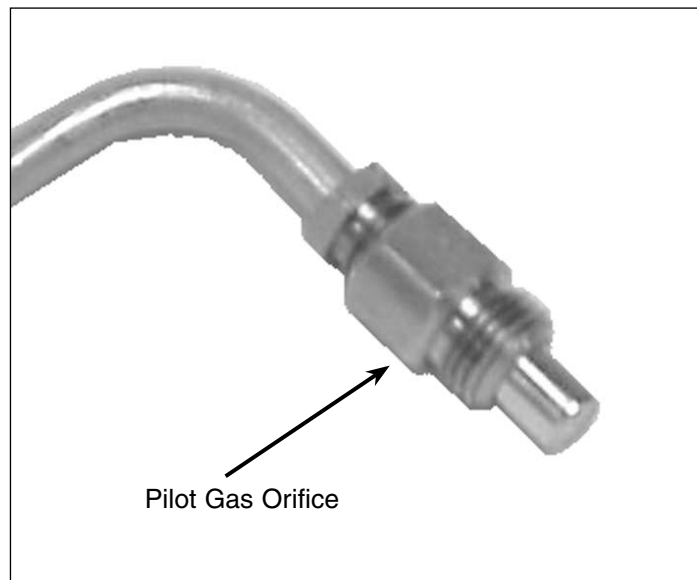

Figure 4.2

Pilot Gas Orifice



HIGH ALTITUDE CONVERSION

High Altitude Conversion (Over 2000 feet elevation) orifice(s) using a wrench and ensure that it is gas tight.

Table 5.1
High Altitude Orifice Kit Selection Guide and Parts List
(Natural Gas)

Convertible Control Codes: 47, 48, 04, 08, 27

	Elevation	2001 to 4500 ft.		4501 to 5500 ft.		5501 to 6500 ft.		6501 to 7500 ft.	
	Model	30/60/90/120	160	30/60/90/120	160	30/60/90/120	160	30/60/90/120	160
Kit Item Code		42561	42563	42561	42564	42562	42565	42562	42566
Kit Part Number		3H36790-1	3H36790-3	3H36790-1	3H36790-4	3H36790-2	3H36790-5	3H36790-2	3H36790-6
High Altitude Conversion Label		5H78225B	5H78225B	5H78225B	5H78225B	5H78225B	5H78225B	5H78225B	5H78225B
Burner Orifice Size (Quantity)		44 (4)	39 (4)	44 (4)	40 (4)	45 (4)	41 (4)	45 (4)	42 (4)

Table 5.2
High Altitude Orifice Kit Selection Guide and Parts List
(Propane Gas)

Convertible Control Codes: 97, 75, 67

	Elevation	2001 to 4500 ft.		4501 to 5500 ft.		5501 to 6500 ft.		6501 to 7500 ft.	
	Model	30/60/90/120	160	30/60/90/120	160	30/60/90/120	160	30/60/90/120	160
Kit Item Code		42567	42568	42567	42568	42567	42568	42567	42569
Kit Part Number		3H36791-1	3H36791-2	3H36791-1	3H36791-2	3H36791-1	3H36791-2	3H36791-1	3H36791-3
High Altitude Conversion Label		5H78225B	5H78225B	5H78225B	5H78225B	5H78225B	5H78225B	5H78225B	5H78225B
Burner Orifice Size (Quantity)		53 (4)	50 (4)	53 (4)	50 (4)	53 (4)	50 (4)	53 (4)	51 (4)

Selection of the Proper Kit

Referring to the model number on the unit serial plate, select the appropriate kit from either Table 5.1 (Natural Gas) or Table 5.2 (Propane Gas).

Example: To convert an MT 90 G 48 for operation at 5000 ft., select Item Code 42561.

- On the High Altitude Conversion label (see Figure 5.1) write the drill size, as stamped on orifice(s), with a permanent marker. Be sure to check correct orifice sizing using Table 5.1 or 5.2. Affix the high altitude conversion label adjacent to the unit's serial plate.

Figure 5.1
High Altitude Conversion Label



Installation of Kit

CAUTION

Gas supply shall be shut off prior to disconnecting the electrical power, before proceeding with the conversion. Failure to do so could result in fire, explosion or electrical shock.

Conversion of any unit is the responsibility of, and the risk of the person making the conversion.

If also converting from natural gas to propane gas during the high altitude conversion, follow the instructions for NATURAL GAS TO PROPANE GAS CONVERSION beginning on page 2. Discard the propane burner orifice of the kit from Table 2.1 and replace it with the high altitude propane burner orifice from the appropriate kit from Table 5.2

All Control Codes

- Ensure gas supply and electrical power disconnections have been made.
- Remove main gas orifice(s). Refer to Figure 3.1.
- Insert high altitude orifice(s) from either Table 5.1 (Natural Gas) or Table 5.2 (Propane Gas) into manifold assembly. Each gas orifice is stamped with the drill size. Discard any extra gas orifices included in the high altitude kit. Tighten gas

- Verify that all controls and wiring have not been damaged.
- Continue with Check-Out Procedure on page 6 of this manual.

CHECK-OUT PROCEDURE

Check-Out Procedure

This is an abbreviated check-out procedure. For additional detail, please see applicable installation and service manual for the appropriate unit.

1. Place pressure taps on both the inlet and outlet pressure taps of the gas valve.
2. Connect a pressure-measuring device capable of reading inches of water column on both the inlet and outlet pressure taps.
3. Restore both the fuel supply and the electrical supply to the unit. Verify the proper ignition sequence. The inlet pressure must be 7-14" WC for natural gas, or 11-14" WC for propane gas. The manifold pressure must be 6" WC for natural gas, or 10" WC for propane gas.
4. No adjustments can be made to the burner flame. Some yellow in the flame is acceptable as long as no carbon (black soot) is being formed. For high intensity units, the ceramic burner should glow bright orange after about 10 minutes of operation.
5. Verify the input rate by checking the correct main burner orifice size and manifold pressure. This information is presented on the conversion kit rating plate.
6. Turn the heater off and replace the inlet and outlet pressure tap plugs.
7. Turn the unit on.
8. Check for leaks at all joints, pressure tap plugs, and connections in the gas lines. This is most easily done with a soap and water solution. Simply brush or spray some of the solution on a joint or connection, and look for possible bubble formation.
9. If additional information is required, please refer to applicable installation and service manual for the specific infrared model.

(This page is intentionally left blank)

