



INSTALLATION INSTRUCTIONS

step-down transformer kit

Models HD/HDB, HDS/HDC, PTP/PTS/BTS, and PTC/BTC

Model PTS with Transformer Accessory Mounted



IMPORTANT

1. The use of this manual is specifically intended for a qualified installation and service agency. All installation and service of these kits must be performed by a qualified installation and service agency.
2. These instructions must also be used in conjunction with the Installation and Service manual originally shipped with the appliance being converted, in addition to any other accompanying component supplier literature.

Model Application

All HD/HDB, HDS/HDC, PTP/PTS, and PTC models utilize 115V propeller and blower motors (except PTP/PTS400 size units, which can be wired for 115V or 230V single phase). Additionally, the power exhaustor motor is 115V. Units come standard with a 115V to 24V factory installed transformer for the control circuit. If the units are to be used with a supply voltage greater than 115V, a field installed step-down transformer from the supply voltage to 115V is required.

For BTC/BTS models, when specified for use on a supply voltage greater than 115V, the unit can be configured with a blower motor that matches the supply voltage. However, the power exhaustor motor and control circuit step-down transformer remain as 115V, requiring a field installed step-down transformer.



WARNING

1. Disconnect power supply before making wiring connections to prevent electrical shock and equipment damage.
2. All appliances must be wired strictly in accordance with the wiring diagram furnished with the appliance. Any wiring different from the wiring diagram could result in a hazard to persons and property.
3. Any original factory wiring that requires replacement must be replaced with wiring material having a temperature rating of at least 105°C.
4. Ensure that the supply voltage to the appliance, as indicated on the serial plate, is not over the rated voltage by more than 5%.



CAUTION

Ensure that the supply voltage to the appliance, as indicated on the serial plate, is not under the rated voltage by more than 5%.

INSTALLATION – STEP-DOWN TRANSFORMER

Assembly/Installation

The recommended procedure for assembly and installation is described as follows:

1. Installation of wiring must conform with local building codes, or in the absence of local codes, with the National Electric Code ANSI/NFPA 70 - Latest Edition. Unit must be electrically grounded in conformance to this code. In Canada, wiring must comply with CSA C22.1, Part 1, Electrical Code.
2. Disconnect supply voltage.
3. Verify electrical system supply to ensure it matches the transformer primary voltage rating.
4. Verify that the unit supply power listed on the serial plate is 115V or 115/230V, 60 Hertz, 1 Phase.
5. Verify that the transformer is correctly sized for the unit type and size (see Table 3.1).
6. Mount the transformer to the mounting bracket using the #10-24x1/2" machine screws and nuts and/or the 1/4"-20 x 3/4" cap screws and 1/4" nuts provided depending on the transformer size. The 0.25kVA transformers mount with #10 machine screws only, while 0.5kVA and larger may use either or both types of fasteners. Cap screws must be inserted from the back of the mounting bracket and into the transformer mounting holes as shown in Figure 2.1, requiring that the transformer j-box cover be removed for assembly.

Figure 2.1
Transformer to Mounting Bracket Assembly

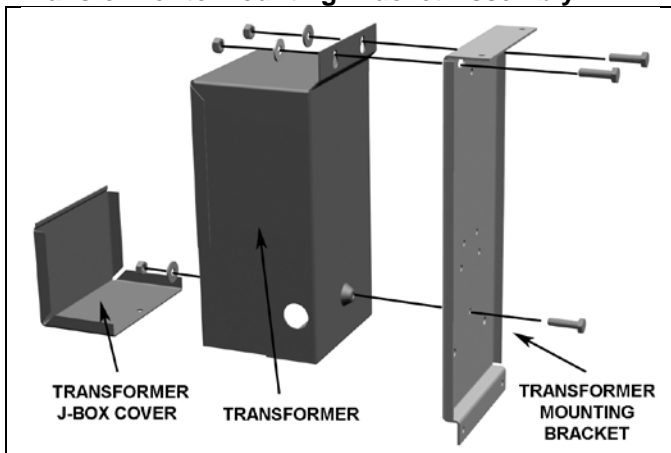

7. Mount the transformer/mounting bracket assembly on the non-access side (right side when looking into the discharge air opening), toward the back of the unit heater by placing the bracket over the top edge of the unit and attaching with self-drilling screws provided as shown in Figure 2.2.
8. Insert the foam pad between the bottom of the mounting bracket and the unit heater side panel as shown in Figure 2.2. Use two self-drilling screws to fasten the transformer mounting bracket to the side panel.

Figure 2.2
Transformer/Mounting Bracket to Unit Assembly

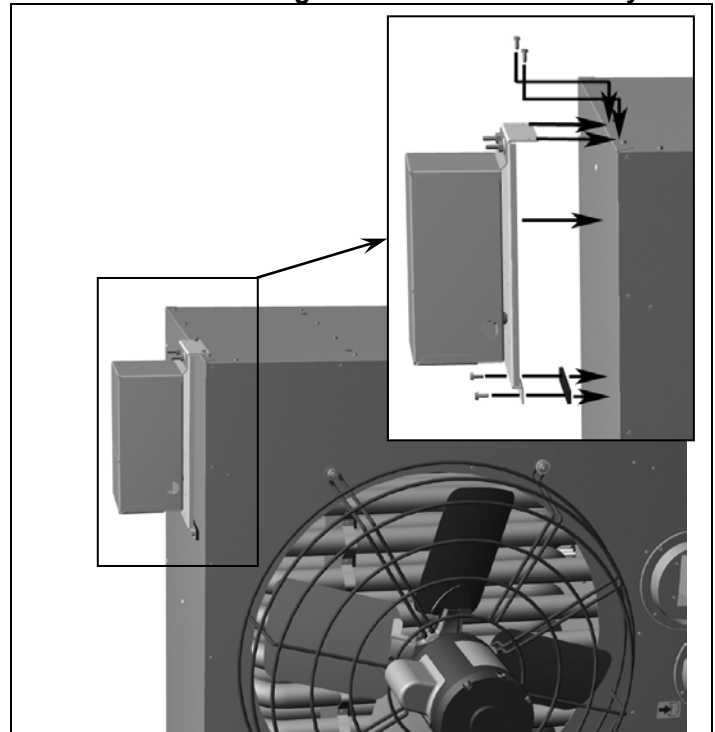

9. Connect the conduit wiring harness provided with the kit to the transformer and wire to the secondary side (labeled X1, X2, X3, and X4) of the transformer. Transformer secondary wires X1 and X3 are to be interconnected and wired to the black harness wire. Transformer secondary wires X2 and X4 are to be interconnected and wired to the white harness wire. See Table 3.2 for summary of connections.
10. For all models except BTC/PTC, route the conduit neatly down the side and across the lower back of the unit to the unit heater power connections, cutting to the desired length. For model BTC/PTC, route the conduit neatly across the upper back of the unit to the heater power connections in the external junction box, cutting the harness to the desired length. Use the clamps provided to hold conduit in place. Seal the connections where they enter the casing.
11. Connect the wiring harness ends in the unit heater as shown on the unit heater wiring diagram supplied with the unit. For 115V single-phase power units, all power is supplied through the transformer. For units with 115/230V motors powered from a 230V circuit, only the controls are powered through the transformer. Power for the 230V motor circuit is supplied to the internal relay via the red and blue harness wires.
12. Connect the incoming electrical power supply wiring to the transformer j-box with an appropriate connector.

INSTALLATION – STEP-DOWN TRANSFORMER

13. Connect the supply power wires to the transformer primary wires (labeled H1, H2, etc.). For units 115V/230V units used with 230V/1ph supply power, also connect the red and blue harness wires to these leads to supply power to motor relay inside the cabinet. Refer to the unit wiring diagram and connection charts in Table 3.2 that correspond to the supply voltage. Connection charts are also provided in the transformer casing.
14. Connect the building circuit ground to the transformer grounding lug.
15. Turn the power supply on to unit. Verify the voltage from the transfer to unit controls and, if so equipped, the motor relay. Also verify that the unit operates as detailed in the unit Installation and Service Manual.

Table 3.1 – Accessory Transformer Sizing and Selection

Model Type	Model	Supply Voltage:	208V		230V		460V		575V	
			1 or 3 ph		1 or 3 ph		3 ph		3 ph	
		Model Size	KVA	Item Code	KVA	Item Code	KVA	Item Code	KVA	Item Code
Propeller	HD/HDS	30-75	0.5	55843	0.5	55847	0.5	55847	0.5	55852
		100-125	1	55844	0.75	55848	0.75	55848	0.75	55853
	PTP/PTS	150-175	1	55844	0.75	55848	0.75	55848	0.75	55853
		250	1	55844	1	55849	1	55849	1	55854
		300-350	1.5	55845	1.5	55850	1.5	55850	1.5	55855
		400	1.5	55845	0.25 ①	55846	1.5	55850	1.5	55855
	PTC	85-180	1	55844	1	55849	1	55849	1	55854
215-310		1.5	55845	1.5	55850	1.5	55850	1.5	55855	
Blower	HDB/HDC	60-75	1	55844	1	55849	1	55849	1	55854
		100-125	1.5	55845	1.5	55850	1.5	55850	1.5	55855
	BTC/BTS	150-260 ②	0.5	55843	0.5	55847	0.5	55847	0.5	55852
		300-400 ②	0.5	55843	0.25	55846	0.25	55846	0.25	55851

① PTP/PTS units used on 230V/1ph, all models are equipped with 115V motors except the PTS400 which is equipped with a motor that can operate on 115V or 230V. Since the transformer does not need to be sized to include the propeller motor, the rating of the Step Down Transformer Accessory is sized smaller for the power exhaustor and gas control circuit only.

② BTC/BTS150-400 size units are supplied with a motor that can operate on the selected voltage without a transformer (all HDB & HDC sizes are 115V only), the rating of the Step Down Transformer Accessory is sized for the power exhaustor and gas control circuit only. For 230V and up on BTS300-400 size models, the transformer size is smaller than the 150-250 size because the power exhaustor motor is a PSC type, which has a lower amp draw.

Table 3.2 – Step Down Transformer Wiring Connections

Supply Voltage	208V			240V	480V	600V		
Supplier	Hevi-Duty		Jefferson	All	All	Hevi-Duty	Jefferson	
Transformer Size (kVA)	1.0	1.5	All	All	All	All	0.25 to 1.0	1.5
Interconnect Primary Connections:	H2 to H3	H2 to H7	None Required	H1 to H3 H2 to H4	H2 to H3	None Required	None Required	
Connect Primary Lines To Incoming Power:	H1 & H4	H1 & H8	H1 & H2	H1 & H4	H1 & H4	H1 & H2	H1 & H2	H1 & H6
Interconnect Secondary Connections:	X1 to X3 X2 to X4			X1 to X3 X2 to X4	X1 to X3 X2 to X4	X1 to X3 X2 to X4		
Connect Secondary Lines To Unit:	X1 & X4			X1 & X4	X1 & X4	X1 & X4		

Modine Manufacturing Company has a continuous product improvement program,
and therefore reserves the right to change design and specifications without notice.

Modine Manufacturing Company • 1500 DeKoven Avenue • Racine, Wisconsin, USA 53403-2552
Phone: 1.800.828.4328 (HEAT) • www.modinehvac.com

© Modine Manufacturing Company 2015

6-567.3