

INSTALLATION AND SERVICE MANUAL

separated combustion high efficiency gas-fired unit heaters models PSH & BSH



All models approved for use in California by the CEC (when equipped with IPI), in New York by the MEA division, and in Massachusetts. Unit heater is certified for non-residential applications.

Contents

	Page
Inspection on arrival	1
Installation	2
Performance data	10
Dimensional data	11
Operation	16
Checking input rate	16
Propeller heaters	19
Service instructions	21
Troubleshooting guide	22
Motor data	25
Control options	26
Rating plate identification	27
Warranty	Back cover

! WARNING

Improper installation, adjustment, alteration, service or maintenance can cause property damage, injury or death, and could cause exposure to substances which have been determined by various state agencies to cause cancer, birth defects or other reproductive harm. Read the installation, operating and maintenance instructions thoroughly before installing or servicing this equipment.

FOR YOUR SAFETY

The use and storage of gasoline or other flammable vapors and liquids in open containers in the vicinity of this appliance is hazardous.

! CAUTION

To prevent premature heat exchanger failure do not locate ANY gas-fired units in areas where chlorinated, halogenated or acid vapors are present in the atmosphere.

FOR YOUR SAFETY

If you smell gas:

- 1. Open windows**
- 2. Don't touch electrical switches.**
- 3. Extinguish any open flame.**
- 4. Immediately call your gas supplier.**

THIS MANUAL IS THE PROPERTY OF THE OWNER. PLEASE BE SURE TO LEAVE IT WITH THE OWNER WHEN YOU LEAVE THE JOB.

Inspection on Arrival

1. Inspect unit upon arrival. In case of damage, report immediately to transportation company and your local Modine sales representative.
2. Check rating plate on unit to verify that power supply meets available electric power at the point of installation.
3. Inspect unit received for conformance with description of product ordered (including specifications where applicable).

INSTALLATION

SPECIAL PRECAUTIONS

THE INSTALLATION AND MAINTENANCE INSTRUCTIONS IN THIS MANUAL MUST BE FOLLOWED TO PROVIDE SAFE, EFFICIENT AND TROUBLE-FREE OPERATION. IN ADDITION, PARTICULAR CARE MUST BE EXERCISED REGARDING THE SPECIAL PRECAUTIONS LISTED BELOW. FAILURE TO PROPERLY ADDRESS THESE CRITICAL AREAS COULD RESULT IN PROPERTY DAMAGE OR LOSS, PERSONAL INJURY, OR DEATH.

1. Disconnect power supply before making wiring connections to prevent electrical shock and equipment damage. All units must be wired strictly in accordance with wiring diagram furnished with the unit.
2. Turn off all gas before installing unit heaters.
3. Gas pressure to unit heater controls must never exceed 14" W.C. (1/2 psi).

When leak testing the gas supply piping system, the unit and its combination gas control must be isolated during any pressure testing in excess of 14" W.C. (1/2 psi).

The unit should be isolated from the gas supply piping system by closing its field installed manual shut-off valve.
4. Check gas inlet pressure at unit upstream from combination gas control. The inlet pressure should be 6" - 7" W.C. on natural gas or 11" - 14" W.C. on propane gas. Purging of gas piping should be performed as described in ANSI Z223.1 - Latest Edition or in Canada in CAN/CGA-B149 codes.
5. All units must be supplied with both combustion air and exhaust piping to the outdoors.
6. Do not install in potentially explosive or flammable atmospheres laden with grain dust, sawdust, or similar air-borne materials. In such applications, a blower type heater installed in a separate room with ducting, including appropriate back flow prevention dampers to the dust-laden room, is recommended.
7. Installation of units in high humidity or salt water atmospheres will cause accelerated corrosion resulting in a reduction of the normal life span of the units.
8. To prevent premature failure **do not located ANY gas-fired unit heaters in areas where chlorinated, halogenated or acid vapors are present in the atmosphere.**
9. Maintain separation between units so discharge from one unit will not be directed into the inlet of another.
10. Do not install unit outdoors.
11. Minimum clearance to combustibles is 12 inches from the bottom; 18 inches from the sides; 6 inches from the top and vent connector.
12. Allow at least 6" clearance at the sides and 12" clearance at rear (or 6" beyond end of fan motor at rear of unit, whichever is greater) to provide ample air for combustion and proper operation of fan.
13. The minimum distance from combustible material is based on the combustible material surface not exceeding 160°F. Clearance from the top of the unit may be required to be greater than 6" if heat damage, or other than fire, may occur to materials above the unit heater at the temperature described.
14. Do not install units below 7 feet, measured from the bottom of the unit to the floor, unless properly guarded to provide protection from moving parts.
15. Modine units are designed for use in heating applications with ambient temperatures between 32°F and 90°F. If an

application exists where ambient temperatures can be expected to fall outside of the is range, contact factory for recommendations.

16. Provide clearance for opening hinged bottom pan for servicing. See Figure 2. Do not set unit on its bottom.
17. To assure that flames do not impinge on heat exchanger surfaces, the unit must be suspended in a vertical and level position. Failure to suspend unit properly may shorten the life of the unit heater.
18. Do not life unit by power exhauster.
19. Be sure no obstructions block air intake and discharge of unit.
20. Do not attach duct work, air filters, or polytubes to any propeller (PSH) model unit.
21. In aircraft hangars, keep the bottom of the unit at least 10' from the highest surface of the wings or engine enclosure of the highest aircraft housed in the hanger and in accordance with the requirements of the enforcing authority and/or NFPA No. 409 — Latest Edition.
22. In garages or other sections of aircraft hangars such as offices and shops that communicate with areas used for servicing or storage, keep the bottom of the unit at least 7' above the floor unless the unit is properly guarded to provide user protection from moving parts. In parking garages, the unit must be installed in accordance with the standard for parking structures ANSI/NFPA 88A, and in repair garages the standard for repair garages NFPA #88B. In Canada, installation of unit heaters in airplane hangars must be in accordance with the requirements of the enforcing authority, and in public garages in accordance with the current CAN/CGA-B149 codes.
23. Consult piping, electrical, and venting instructions in this manual before final installation.
24. All literature shipped with your unit should be kept for future use for servicing or service diagnosis. Do not discard any literature shipped with your unit.
25. When servicing or repairing this equipment, use only Modine-approved service replacement parts. A complete replacement parts list may be obtained by contacting Modine Manufacturing Company. Refer to the rating plate on the unit for complete unit model number, serial number and company address. Any substitution of parts or controls not approved by Modine will be at owners risk.

Figure 2
Hinged Bottom for Burner Service
(See Dimension "C", page 19)



INSTALLATION

Product Description

Modine PSH and BSH model unit heaters are listed as separated combustion unit heaters and are defined as follows: A unit heater for installation in non-residential structures which, when connected to a sealed combustion air pipe and sealed exhaust vent, supplied by the installer, constructed so that when installed according to the manufacturer's instructions, air for combustion is derived from the outside atmosphere and the flue gases from the appliance are discharged to the outside atmosphere and the flue gases from the appliance are discharged to the outside atmosphere.

In the U.S., the installation of these units must comply with the "National Fuel Gas Code," ANSI Z223.1, latest edition (also known as NFPA 54) and other applicable local building codes.

In Canada, the installation of these units must comply with local plumbing or waste water codes and other applicable codes and with the current code CAN/CGA-B149.1, "Installation Code for Natural Gas Burning Appliances and Equipment" or CAN/CGA-B149.2, "Installation Code for Propane Burning Appliances and Equipment."

1. All installation and service of these units must be performed by a qualified installation and service agency only as defined in ANSI Z223.1, latest edition or in Canada by a licensed gas fitter.
2. This unit is certified by C.S.A., with the controls furnished. For replacement parts, submit the complete model, control code and serial number shown on rating plate on the unit, Modine reserves the right to substitute other authorized controls as replacements.
3. Unit is balanced for correct performance. Do not alter fan or operate motors at reduced speed.
4. Information on controls is supplied separately.
5. Modine unit heaters use the same burner for natural and propane gases.

Locating Unit Heaters

CAUTION

Units must not be installed in potentially explosive, flammable or corrosive atmosphere.

To prevent premature heat exchanger failure do not locate ANY gas-fired unit in areas where chlorinated, halogenated or acid vapors are present in the atmosphere.

In locating units, consider general space-heating requirements, availability of gas, and proximity to vent locations. Unit heaters should be located so heated air streams wipe exposed walls without blowing directly against them. In multiple unit installations, arrange units so that each supports the air stream from another, setting up circulatory air movement in the area. In buildings exposed to prevailing winds, a large portion of the heated air should be directed along with windward wall. Avoid interference of air streams as much as possible.

Mounting height (measured from bottom of unit) at which unit heaters are installed is critical. Maximum mounting heights for standard units are listed in Tables 7 and 8 on page 18. Alternate mounting heights for units with deflector hoods or nozzles are shown on pages 10 and 12. The maximum mounting heights for any unit is that heights above which the unit will not deliver heated air to the floor. The maximum mounting heights must not be exceeded in order to assure maximum comfort.

Motors and controls used on Modine unit heaters are designed for use in ambient temperatures between 32°F and 90°F. If an application exists where ambient temperatures can be expected to fall outside of this range, contact factory for recommendations.

Combustion Air Requirements

Modine models PSH and BSH separated combustion units are designed to receive air for combustion directly from the outside atmosphere via field installed combustion air piping between the unit and the outside atmosphere. **The combustion air inlet of the unit must be connected to the outside atmosphere.**

The maximum equivalent length of combustion air piping cannot exceed 30 feet. Keep this limitation in mind when locating units. See page 5 for combustion air piping instructions.

Unit Suspension

CAUTION

Minimum clearance to combustibles is 12 inches from the bottom; 18 inches from the sides; 6 inches from the top and vent connector.

Allow at least 12" at the rear of unit or 6" beyond the end of the motor (Whichever is greater) to provide ample air for proper operation of fan.

Provide clearance for opening hinged bottom of servicing. See Figure 2.

Be sure the means of suspension is adequate to support the weight of the unit. (See page 19 for unit weights.) For proper operation, the unit must be installed in a level horizontal position. Clearances to combustibles as specified above must be strictly maintained.

On all propeller units except the PSH280 and PSH340, two tapped holes (3/8 - 16) are located in the top of the unit to receive ceiling hangers. Units with two point suspension, models PSH130 through PSH225, incorporate a level hanging feature. Depending on what options and accessories are being used, the heater may not hang level as received from the factory. Do not hang heaters with deflector hoods until referring to the "installation manual for deflector hoods" and making the recommended preliminary adjustments on the heater. These preliminary adjustments need to be made with the heater resting on the floor.

PSH130 through PSH225 units without deflector hoods that do not hang level after being installed, can be corrected in place. Simply remove both outer side panels (screws to remove are on back flange of side panel) and you will see the (adjustable) mounting brackets (Figure 3). Loosen the set screws holding the mounting brackets in place and using a rubber mallet or something similar, tap the heater into a position where it does hang level. Re-tighten set screws and replace the outer side panels.

The PSH280 and PSH340 have four mounting holes. On all blower units, except the BSH280 and BSH340, two tapped holes are provided in the top of the unit and two holes in the blower support bracket. The BSH280 and BSH340 have four tapped holes in the top of the unit and two in the blower support bracket for mounting. **To assure that flames are directed into the center of heat exchanger tubes, unit must be supported in a vertical position, with suspension hangers "UP." Check with a level. This is important to the operation and life of unit.**

NOTE: Pipe hanger adapter kits, as shown in Figure 3, are available as accessories from Modine. The hardware allows for pipe caps to be secured into the top of the unit heater with machine screws (as illustrated - machine screws are 3/8 - 16 x 1.75 UNC-2A THD). The pipe caps can then accommodate 3/4" NPT pipe for mounting. Three different kits are available with either 2, 4, or 6 adapters per kit. See price sheet to determine proper kit.

INSTALLATION

Figure 2
Suspension Methods

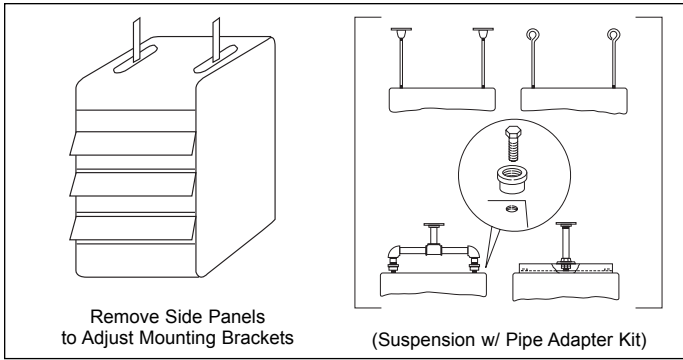

Venting

General Venting and Combustion Air Instructions

⚠ CAUTION

Gas-fired heating equipment must be vented — do not operate unvented.

A built-in power exhauster is provided — additional external draft hoods (diverters) or power exhausters are not required or permitted.

Installation must conform with local building codes or in the absence of local codes, with the National Fuel Gas Code, ANSI Z223.1 (NFPA 54) — Latest Edition. In Canada installation must be in accordance with CAN/CGA-B149.1 for natural gas appliances, and CAN/CGA-B149.2 for propane appliances.

Table 1
ANSI venting requirements

Appliance Category	Description	Venting Requirements
I	Negative vent pressure Non-condensing	Follow standard venting requirements.
II	Negative vent pressure Condensing	Condensate must be drained.
III	Positive vent pressure Non-condensing	Vent must be gastight.
IV	Positive vent pressure Condensing	Vent must be liquid and gastight. Condensate must be drained.

- Table 1 summarizes the ANSI venting requirements for the various appliance categories. All PSH/BSH models are category III appliances. The venting requirements for a category III appliance are included in these instructions.
- Select the size of vent and combustion air pipe that fits the power exhauster and combustion air intake on the rear of the appliance (see pages 14 and 15 for dimensions). Do not use a vent or combustion air pipe smaller than the size of the outlet or inlet on the appliance. The pipe should be single wall galvanized steel or other suitable corrosion resistant material. Follow the National Fuel Gas Code for minimum thickness of vent material. The minimum thickness for connectors varies depending on the pipe diameter.
- A minimum of 12 inches straight pipe is recommended from the power exhauster outlet before turns in the vent pipe.

- Install the vent and combustion air pipes with a downward slope from the appliance of 1/4 inch per foot and suspend securely from overhead structures at points no greater than 3 feet apart. Fasten individual lengths of vent together with at least three corrosion resistant sheet metal screws.
- Keep the vent pipe at least 6 inches from combustible material. The minimum distance from combustible material is based on the combustible material surface not exceeding 160F. Clearance from the vent pipe (or the top of the unit) may be required to be greater than 6 inches if heat damage other than fire (such as material distortion or discoloration) could result.
- Avoid venting through unheated space when possible. When venting does pass through an unheated space, insulate runs greater than 5 feet to minimize condensation. Inspect for leakage prior to insulating and use insulation that is noncombustible with a rating of not less than 350F. Install a tee fitting at the low point of the vent system and provide a drip let with a clean out cap as shown in figure 01. The drip leg should be cleaned annually.
- When the vent passes through an INTERIOR wall or floor, a metal thimble 4 inches greater than the vent diameter is necessary. If there is 6 feet or more of vent pipe in the open space between the unit heater and where the vent pipe passes through the wall or floor, the thimble need only be 2 inches greater than the diameter of the vent pipe. If a thimble is not used, all combustible material must be cut away to provide a 6 inches clearance. Any material used to close the opening must be noncombustible.
- Limit the total equivalent vent pipe length to a minimum of 5 feet and a maximum of 30 feet, making the vent system as straight as possible. (The equivalent length of a 4 inch elbow is 5 feet and a 6 inch elbow is 10 feet).
- Seal the joints with a metallic tape suitable for temperatures up to 350F. (3M tapes 433 or 363 are acceptable.) Wrap the tape two full turns around the vent pipe.
- Do NOT vent this appliance into a masonry chimney.
- Do NOT use dampers or other devices in the vent or combustion air pipes.
- The venting system must be exclusive to a single appliance, and to other appliance is allowed to be vented into it.
- Long runs of horizontal or vertical combustion air pipes may require insulation in very cold climates to prevent the buildup of condensation on the outside of the pipe where the pipe passes through conditioned spaces.
- Vertical combustion air pipes should be fitted with a tee with a drip leg and a clean out cap to prevent against the possibility of any moisture in the combustion air pipe from entering the unit. The drip leg should be inspected and cleaned periodically during the heating season.
- When condensation may be a problem, the vent system shall not terminate over public walkways or over an area where condensate or vapor could create a nuisance or hazard or could be detrimental to the operation of regulator, relief openings or other equipment.
- Precautions must be taken to prevent degradation of building materials by flue products.
- The vent cap for vertically vented appliances should extend above any portion of a building within a horizontal distance of 2 feet. Refer to figures 7 and 8.

INSTALLATION

Venting Instructions for Concentric Vent Options

The concentric vent concept allows for the vent pipe and the combustion air pipe to pass through one hole in an EXTERIOR wall or roof. The concentric vent kits offered are horizontal or vertical. Venting with 2 pipes; a combustion air pipe and flue product vent pipe remains an option, primarily for replacement heaters where two holes through the exterior of a building already exist.

When utilizing the concentric vent option, you have already pre-determined whether the unit heater will be horizontal vent or vertical vent and have received the appropriate kit. At this time, you need to verify that you have all the components required for the venting option chosen. The components for each kit are as follows:

Horizontal Concentric Vent Kit:

- concentric adapter assembly
- specially designed vent termination cap
- specially designed inlet air guard

Vertical Concentric Vent Kit:

- concentric adapter assembly
- standard Briedert Type L or Gary Steel 1092 vent termination cap
- specially designed inlet terminal

Although the first installation you will make will be the concentric adapter assembly, you should now “**read ahead**” the instructions for the type of venting option you’ve already chosen - i.e. horizontal concentric, vertical concentric, 2 pipe horizontal or 2 pipe vertical. These instructions can be found on pages 5, 6, or 7 of these installation instructions. After reading your specific instructions, come back to “Installing the Concentric Vent Adapter Box” section and begin.

Installing the Concentric Vent Adapter Box

CAUTION

The concentric vent adapter box must be installed inside of the structure or building. Do not install this box on the exterior of a building or structure.

1. Determine the location of the box. Refer to the instructions in the following sections for the method of venting to be used (vertical or horizontal). Maintain all clearances as listed in these instructions.
2. This box can be mounted flush to the wall or roof, or the box can be offset from the wall or roof by using field supplied brackets. When mounting the box, consider serviceability and access to the vent and combustion air pipes.
3. If the box is to be mounted using field supplied brackets, these brackets must be strong enough to rigidly secure the box to the wall or roof, and should be made from corrosion resistant material. After determining the length of the field supplied brackets, attach them to the sides of the box using several corrosion resistant sheet metal screws. See figure 3 for typical installation and brackets.

Adapter Box Dimensions					
Heater Sizes	A	B	C	Concentric Side	
				Exhaust	Combustion
130-225	8 ¹ / ₄ "	11 ³ / ₄ "	4"	4"	6"
280-340	10 ¹ / ₂ "	16"	4"	6"	8"

Figure 3

Adapter Box Assembly with Typical Field Supplied Mounting Brackets

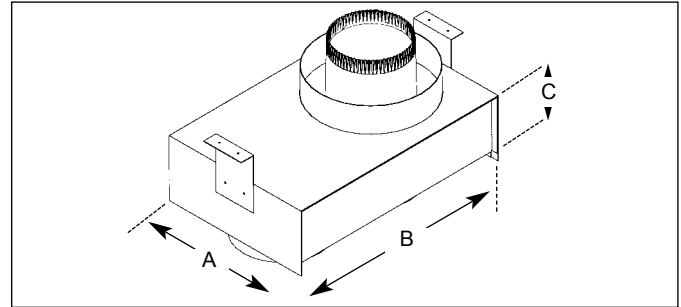

4. Determine the appropriate length of vent pipe that must be attached to the vent outlet (the concentric side) of the box. Refer to the following sections for the minimum length of vent pipe to be used for the method of venting (vertical or horizontal). Make sure to add the length of the field supplied brackets if used, and the thickness of the wall or roof.
5. Cut the vent pipe to the proper length and attach it to the vent outlet of the concentric vent adapter box using at least 3 corrosion resistant sheet metal screws. Seal this joint using metallic tape suitable for temperatures up to 350° F. Wrap the tape two full turns around the vent pipe. See figure 4.

Figure 4

Adapter Box Assembly with Vent Outlet Pipe Attached

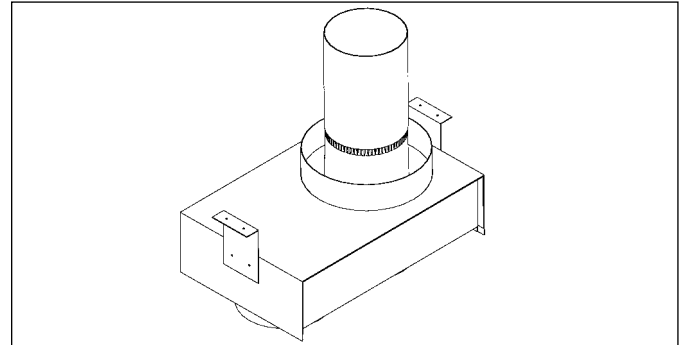

6. Determine the length of the combustion air pipe to extend through the wall. Refer to the following sections for the minimum length of combustion air pipe to be used for the method of venting being used, vertical or horizontal. Cut the pipe to the proper length.
7. Slide the combustion air pipe over the vent pipe. Attach the combustion air pipe to the adapter box using at least 3 non corrosive sheet metal screws. See figure 5.

Figure 5

Adapter Box Assembly with Combustion Air Pipe Attached

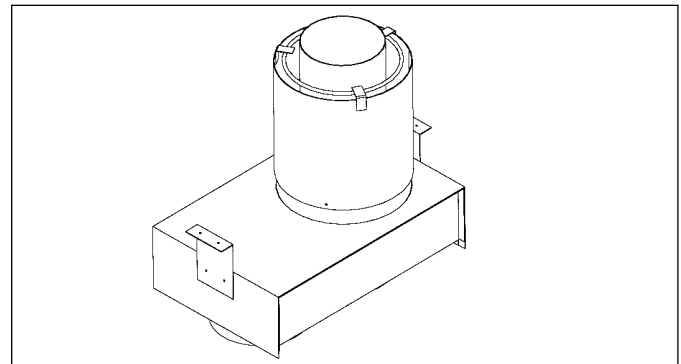

INSTALLATION

- Place this assembly (the adapter box, vent pipe and combustion air pipe) through the wall or roof and verify that the distance requirements as defined in the following sections are met. Securely attach the assembly (adapter box and vent and combustion air pipe) to the wall or roof using appropriate fasteners.

Horizontal Concentric Venting:

Figure 6

Horizontal Concentric Vent (rear pipe hidden)

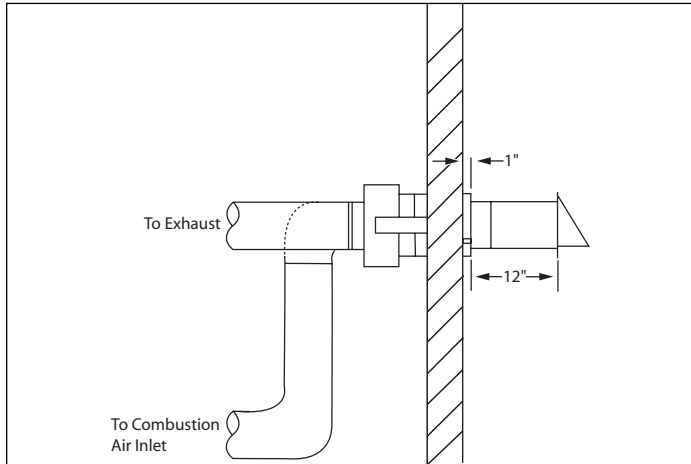

- The vent pipe must terminate with the terminal supplied by the manufacture for horizontal venting. Refer to the parts list on page 5 for the appropriate part.
- The combustion air pipe must terminate at least 1 inch from the wall. This will prevent water from running down the wall and into the pipe and allows for easy installation of the combustion air intake guard.
- Caulk between the wall and the air intake pipe.
- Maintain 12 inches from the combustion air inlet to the back of the vent terminal.
- Attach the combustion air intake guard using non corrosive screws as shown in figure 5. This guard must be placed at the end of the pipe on the exterior of the building. This guard helps to prevent animals and debris from entering the combustion air pipe.

Vertical Concentric Venting:

Figure 7

Vertical Concentric Vent (back view typical)

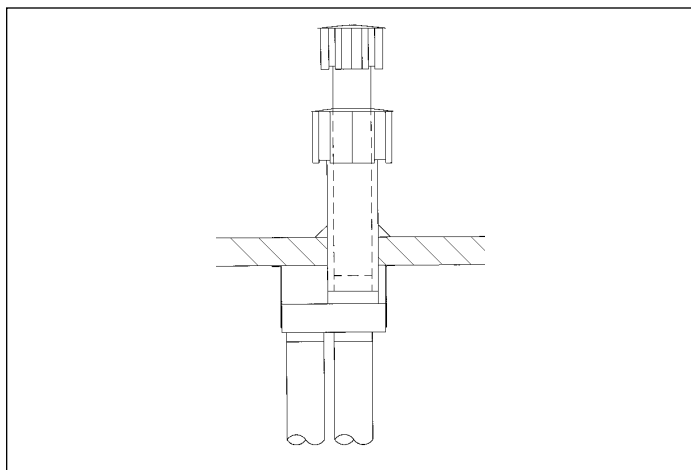

- The vent must terminate with a Gary Steel Model 1092 or Briedert Type L cap for the appropriate pipe size.
- The combustion air pipe must terminate with the cap supplied by the manufacturer. This cap is specially designed to work with the concentric vent system. Refer to the parts list on page 5 for the appropriate part.
- The bottom of the air intake pipe must terminate above the snow line, or at least 12 inches above the roof, which ever distance is greater.
- The bottom of the vent cap must terminate at least 6 inches above the top of the air intake cap.
- To attach the caps, slide the combustion air cap over the vent pipe and fasten it to the combustion air pipe with at least 3 non corrosive fasteners. Then, attach the vent cap to the vent pipe, also using at least 3 non corrosive fasteners.
- Caulk the gap between the combustion air cap and the vent pipe with silicone sealant, or other appropriate sealants suitable for metal to metal contact and for temperatures of 350° F.

Two Pipe Venting

Two pipe venting refers to using two penetrations through an exterior wall or roof. This method of venting is primarily used for replacement heaters where two holes through the exterior of a building exist. To vent using this method, either (2) Briedert Type L caps or (2) Gary Steel Model 1092 caps provided with your unit heater must be used. These caps are used for both vertical and horizontal venting of the heater.

Figure 8

Vertical Venting - Two Pipes

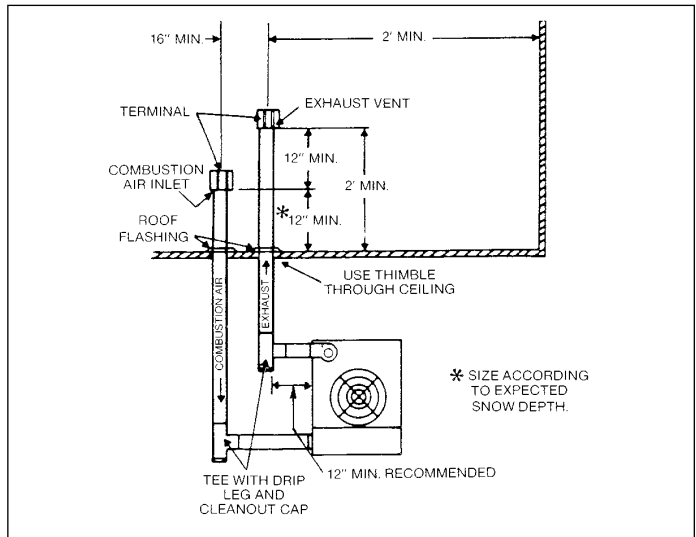

Vertical Two Pipe Venting

- The bottom of the combustion air cap must be located above the snow line or 12 inches above the roof, which ever is greater.
- The vent must terminate at least 1 foot above and 16 inches horizontally from the combustion air inlet.
- When the vent passes through a combustible roof, a metal thimble 4 inches greater than the vent diameter is necessary. If there is 6 feet or more of vertical vent pipe in the open space between the unit heater and where the vent pipe passes through the roof, the thimble need only be 2 inches greater than the diameter of the vent pipe. If a thimble is not used, all combustible material must be cut away to provide a 6 inch clearance. Any material used to close the opening must be noncombustible.

INSTALLATION

Figure 9
Horizontal Venting - Two Pipes

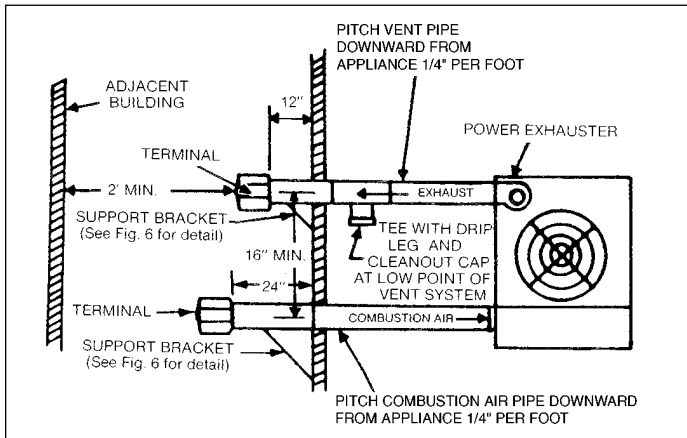

Horizontal Two Pipe Venting

1. When horizontal vents pass through a combustible wall (up to 8 inches thick), the vent passage must be constructed and insulated as shown in Figure 10.
2. The termination of horizontally vented system must extend 12 inches beyond the exterior surface of an exterior wall.
3. The combustion air pipe must be a minimum of 16 inches below the vent pipe, and 24 inches from the exterior wall.
4. Support the vent and combustion air pipe as shown in Figure 10.

Figure 10
Exhaust Vent Construction Through Combustible Walls and Support Bracket

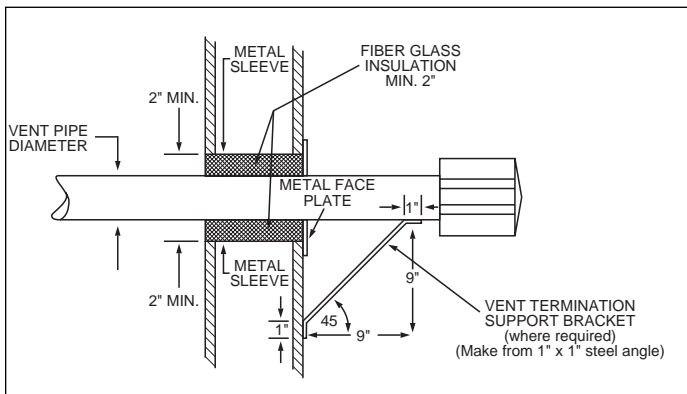

⚠ CAUTION

Gas pressure to unit heater controls must never exceed 14" W.C. (1/2 psi).

When leak testing the gas supply piping system, the appliance and its combination gas control must be isolated during any pressure testing in excess of 14" W.C. (1/2 psi).

The appliance should be isolated from the gas supply piping system by closing its field installed manual shut-off valve.

1. Installation of piping must be in accordance with local codes, and ANSI Z223.1, "National Fuel Gas Code," or CAN/CGA-B149 in Canada.
2. Piping to units should conform with local and national requirements for type and volume and gas handled, and pressure drop allowed in the line. Refer to Table 5, to

Table 2
Gas Pipe Capacities

In Cu. Ft. per Hour with Pressure Drop of 0.3 in W.C. with Specific Gravity 0.60.

Length of Pipe in Ft.	Diameter of Pipe — Inches				
	1/2	3/4	1	1-1/4	1-1/2
15	76	218	440	750	1220
30	73	152	285	590	890
45	44	124	260	435	700
60	50	105	190	400	610
75		97	200	345	545
90		88	160	320	490
105		80	168	285	450
120			158	270	420
150			120	242	380
180			128	225	350
210				205	320
240				190	300
270				178	285
300				170	270
450				140	226
600				119	192

Length of Pipe in Ft.	Diameter of Pipe — Inches				
	2	3	4	6	8
15	2480	6500	12880	38700	79000
30	1650	4700	9700	27370	55850
45	1475	3900	7900	23350	45600
60	1150	3250	6800	19330	39500
75	1120	3000	6000	17310	35300
90	930	2600	5400	15800	32250
105	920	2450	5100	14620	29650
120	860	2300	4800	15680	27920
150	710	2000	4100	12240	25000
180	720	1950	4000	11160	22800
210	660	1780	3700	10330	21100
240	620	1680	3490	9600	19740
270	580	1580	3250	9000	18610
300	545	1490	3000	8500	17660
450	450	1230	2500	7000	14420
600	380	1030	2130	6000	12480

determine the cubic feet per hour (cfh) for the type of gas and size of unit to be installed. Using this cfh value and the length of pipe necessary, determine the pipe diameter from Table 2. Where several units are served by the same main, the total capacity, cfh, and length of main must be considered. Avoid pipe sizes smaller than 1/2". Table 2 allows for the usual number of fittings with a 0.3; W.C. pressure drop. Where the gas supplied has a specific gravity other than 0.60, apply the multiplying factor as given in Table 3.

3. After threading and reaming the ends, inspect piping and remove loose dirt and chips.
4. Support piping so that no strains are imposed on unit or controls.

Table 3
Specific Gravity Conversion Factors

Multiplying factors to be used with Table 1 when the specific gravity of gas is other than 0.60.

Natural Gas		Propane Gas	
Specific Gravity	Factor	Specific Gravity	Factor
0.55	1.04	1.50	0.633
0.60	1.00	1.53	0.626
0.65	0.962	1.60	0.612

INSTALLATION

5. Use two wrenches when connecting piping to unit controls.
6. Provide a drip pocket before each unit and in the line where low spots cannot be avoided. (See Figure 7).
7. Take-off to unit should come from top or side of main to avoid trapping condensate.
8. Piping, subject to wide temperature variations, should be insulated.
9. Pitch piping up toward unit at least 1/4" per 15' of horizontal run.
10. Compounds used on threaded joints of gas piping must be resistant to action of liquefied petroleum gases.
11. Purge air before lighting unit by disconnecting pilot tubing at combination gas control. **In no case should line be purged into heat exchanger.**
12. After installation, check system for gas leaks, using a soap solution.
13. Install a ground joint union and a manual shut off valve immediately upstream of the unit including a 1/8" NPT plugged tapping accessible for test gage connection. (See Figure 7).
14. Allow at least 5 feet of piping between any high pressure regulator and unit control string.
15. When Pressure/Leak testing, pressures above 14" W.C. (1/2 psi), close the field installed shut-off valve, disconnect the appliance and its combination gas control from the gas supply line, and plug the supply line before testing. When testing pressures 14" W.C. (1/2 psi) or below, close the manual shut-off valve on the appliance before testing.

Figure 7
Recommended Piping to Controls

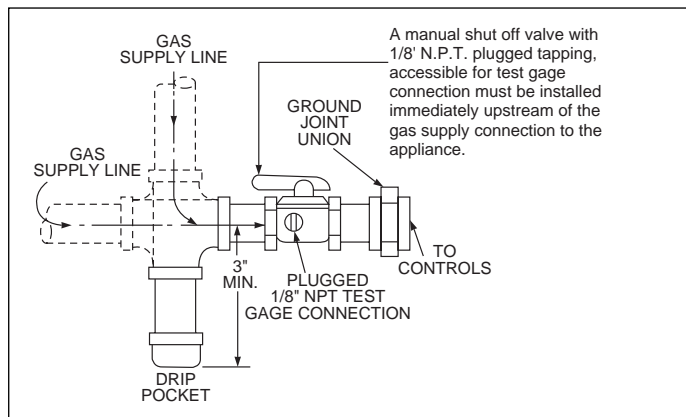

Wiring General

⚠ CAUTION

Disconnect power supply before making wiring connections to prevent electrical shock and equipment damage. ALL UNITS MUST BE WIRED STRICTLY IN ACCORDANCE WITH WIRING DIAGRAM FURNISHED WITH UNIT.

ANY WIRING DIFFERENT FROM WIRING DIAGRAM MAY BE HAZARDOUS TO PERSONS AND PROPERTY.

Any damage to or failure of Modine units caused by incorrect wiring of the units is not covered by MODINE'S STANDARD WARRANTY (see Back Cover).

All field installed wiring must be done in accordance with the National Electrical Code ANSI/NFPA 70 — Latest Edition or Canadian Electrical Code CSA C22.1 Part 1 or local codes. Unit must be electrically grounded according to these codes. See wiring diagram shipped with unit. For optional wiring

diagrams see Bulletin 6-453.

The power to these units should be protected with a fused disconnect. Units for use with three-phase electric power must be provided with a motor starter having properly sized overload protection.

Location of thermostat should be determined by heating requirements and be mounted on an inside wall about 5' above floor level . . . where it will not be affected by heat from the unit or other sources, or drafts from frequently opened doors. See instructions packed with thermostat.

Installation of Blower Models (BSH Units)

⚠ CAUTION

Proper air flow and distribution, across the heat exchanger must be provided to prevent early failure of the blower unit heater.

Attachment of Field Installed Ductwork, Blower BSH Models Only

⚠ CAUTION

Do not attempt to attach ductwork of any kind to propeller PSH models.

Burned-out heat exchanger and shorter equipment life will result from not providing uniform air distribution.

When installing unit, always follow good duct design practices for even distribution of the air across the heat exchanger. Recommended layouts are shown below. When installing blower units with ductwork, the following must be done.

1. **Provide uniform air distribution over the heat exchanger.** Use turning vanes where required. See figures below.
2. Provide removable access panels in the ductwork on the downstream side of the unit. These openings should be large enough to view smoke or reflect light inside the casing to indicate leaks in the heat exchanger and to check for hot spots on exchanger due to poor air distribution or lack of sufficient air (cfm).
3. If ductwork is connected to the rear of the unit, use Modine blower enclosure kit, or if using field designed enclosure, maintain dimensions of proper blower enclosure as shown on page 19.

⚠ CAUTION

Check for red heat exchanger tubes. If bottom of tubes become red while blower unit is in operation, check for proper air volume and air distribution. Adjust blower speed or correct discharge duct design to correct problem.

Installation of Blower Units (BSH)

Determining Blower Speed

The drive assembly and fan motor on all gas-fired blower units are factory assembled. The adjustable motor sheave has been pre-set to obtain maximum air flow without any external static pressure. The motor sheave should be adjusted as required when the unit is to be operated at other air flows and/or with external static pressures. Adjustment must always be within the performance range shown on pages 14 and 15 and the temperature rise range shown on the unit's rating plate.

To determine the proper blower speed and motor sheave turns open, the conditions under which the unit is to operate must be known. If the blower unit is to be used without duct work, nozzles or filters, the only criteria for determining the motor sheave turns open and blower speed is the amount of air flow to be delivered. The performance tables for blower models are shown

INSTALLATION

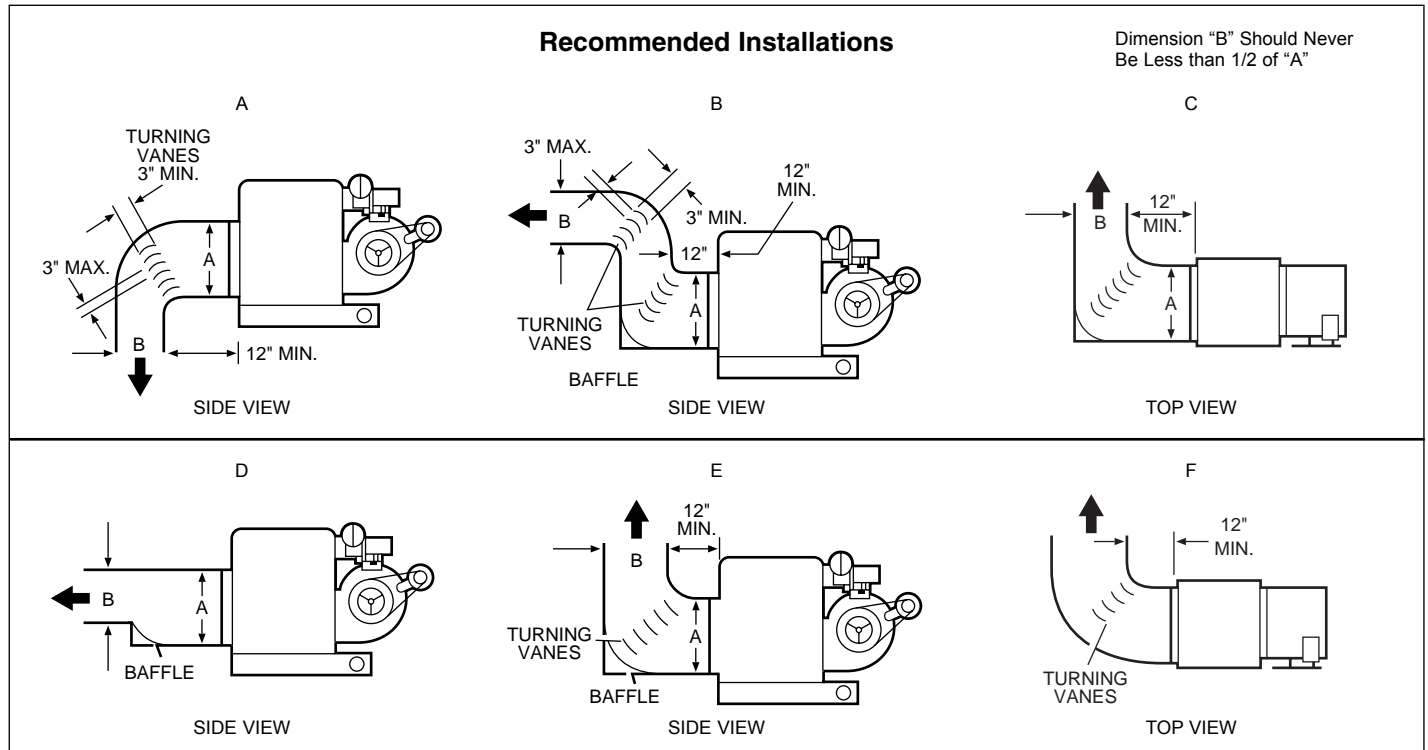

on pages 14 and 15. As an example, a model BSH150 unit without filters operating with one external static pressure, that is, no duct work, nozzles, etc., and is to deliver an air flow of 2071 cfm (cfm = cubic feet of air) requires that the unit be supplied with a 1/2 hp motor, a C25 drive and, the motor sheave set at 5 turns open to achieve a blower speed of 255 rpm (see performance table for units **without** blower enclosure, page 14). See "Blower Adjustments" for setting of motor sheave turns open.

If a blower unit is to be used with ductwork or nozzles, etc., the total external static pressure under which the unit is to operate, and the required air flow must be known before the unit can be properly adjusted. Any device added externally to the unit, and which the air must pass through, causes a resistance to air flow. This resistance is called pressure loss. The total of the pressure losses must be determined before adjusting the blower speed.

If Modine filters are used, the expected pressure loss through the filters is included in performance data on page 15. If Modine supplied discharge nozzles are used, the expected pressure loss of the nozzles can be found footnoted at the bottom of page 10. If filters, nozzles, or ductwork are to be used with the unit, and they are not supplied by Modine, the design engineer or installing contractor must determine the pressure loss for the externally added devices, or ductwork, to arrive at the total external static pressure under which the unit is to operate.

Once the total external static pressure and the required air flow are known, the operating speed of the blower can be determined and the correct motor sheave adjustments made. As an example, let's say a model BSH150 is to be used with a Modine supplied blower enclosure, Modine supplied filters, are to be attached to ductwork supplied by others, and the unit is to move 2071 cfm of air flow against an external static pressure of 0.2" W.C. static pressure, it is seen that the unit will require a 1/2 hp motor using a C22 drive, and the motor sheave should be set at 1 turn open to achieve a blower speed of 415 rpm. See "Blower Adjustments" for setting of motor sheave turns open.

To Install (Figure 8):

1. Remove and discard the tie down strap and the shipping block beneath the belt tension adjusting screw. (Not used on all models.)
2. Adjust belt tension adjusting screw for a belt deflection of

approximately 3/4" with five pounds of force applied midway between the sheaves (refer to Figure 9a). Since the belt tension will decrease dramatically after an initial run-in period, it is necessary to periodically re-check the tension. excessive tension will cause bearing wear and noise.

3. The blower bearings are lubricated for life; however, before initial unit operation the blower shaft should be lubricated at the bearings with SAE20 oil. This will reduce initial friction and start the plastic lubricant flowing.
4. Make electrical connections according to the wiring diagram.
5. Check rotation of the blower. Motor should be in clockwise rotation when facing motor pulley. If rotation is incorrect, correction should be made by interchanging wiring within the motor. See wiring diagram on the motor.
6. The actual current draw of the motor should be determined. Under no condition should the current draw exceed that shown on the motor rating plate.

**Figure 8
Blower Model Installation**

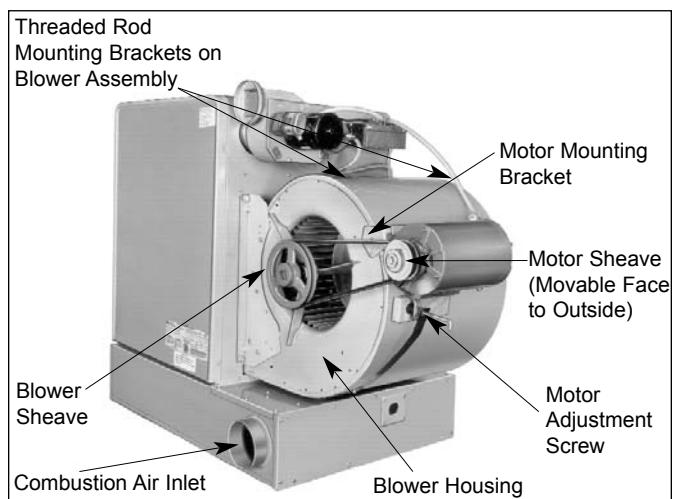

7. **It is the installer's responsibility to adjust the motor sheave to provide the specified blower performance as listed on pages 14 and 15, for blower settings different**

from the factory set performance. The drive number on the unit may be identified by referring to the Power Code number on the serial plate of the unit (see page 23 for model number nomenclature) and matching that number with those shown on page 25. From the listing the drive number can be determined.

- Blower sheave and motor sheave should be measured to assure correct drive is on unit. Refer to page 25 for drive sizes.

Blower Adjustments

Following electrical connections, check blower rotation to assure blow-through heating. If necessary, change wiring to reverse blower rotation. Start fan motor and check blower sheave RPM with a hand-held or strobe-type tachometer. RPM should check out with the speeds listed in Performance Data shown on pages 14 and 15 according to the job specifications. A single-speed motor with an adjustable motor sheave is supplied with these units. If blower speed changes are required, adjust motor sheave as follows:

NOTE: Do not fire unit blower adjustment has been made or unit may cycle on limit (overheat) control.

- Shut-off power before making blower speed adjustments.** Refer to Determining Blower Speed on page 8 and to Blower Drive Selection on pages 14 and 15 to determine proper blower RPM.
- Loosen and take belt off of motor sheave.
- Loosen set screw on outer side of adjustable motor sheave. (see Figure 9).
- To reduce the speed of the blower, turn outer side of motor sheave counterclockwise.
- To increase the speed of the blower, turn outer side of motor sheave clockwise.
- Retighten motor sheave set screw, replace belt and retighten motor base. Adjust belt tension adjusting screw such that there is 3/4" belt deflection when pressed with 5 pounds of force midway between the blower and motor sheaves (see Figure 9a). Since the belt tension will decrease dramatically after an initial run-in period, it is necessary to periodically re-check the tension to assure continual proper belt adjustment.
- Check to make certain motor sheave and blower sheave are aligned. Re-align if necessary.
- Re-check blower speed after adjustment.
- Check motor amps. Do not exceed amps shown on motor nameplate. Slow blower if necessary.
- Check air temperature rise across unit. Check temperature rise against values shown in Performance Tables on pages 14 and 15 to assure actual desired air flow is being achieved.
- If adjustments are required, re-check motor amps after final blower speed adjustment.

**Figure 9
Motor Sheave Adjustment**

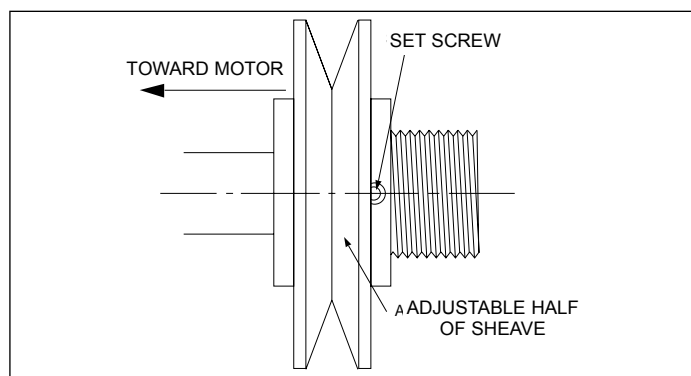

OPERATION

**Figure 9a
Belt Tension Adjustment**

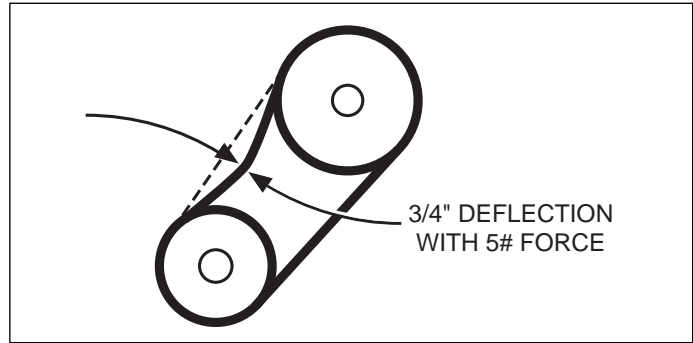

CAUTION

Start-up and adjustment procedures should be performed by a qualified serviceman.

Check the gas inlet pressure at the unit upstream of the combination gas control. The inlet pressure should be 6"-7" W.C. on natural gas or 11"-14" W.C. on propane. If inlet pressure is too high, install an additional pressure regulator upstream of the combination gas control.

The pilot flame must be adjusted as described below. Purging of air from gas lines, piping, and lighting the pilot should be performed as described in ANSI Z223.1-latest edition "National Fuel Gas Code" (CAN/CGA-B149 in Canada).

Be sure no obstructions block air intake and discharge of unit heater.

Prior to Operation

Although this unit has been assembled and fire-tested at the factory, the following pre-operational procedures should be performed to assure proper on-site operation.

- Turn off power.
- Check burner to insure proper alignment.
- Check fan clearance. Fan should not contact casing when spun by hand.
- Check all electrical connections to be sure they are secure.
- If you are not familiar with the unit's controls (i.e. combination gas control), refer to the control manufacturer's literature supplied with the unit.
- Check that all horizontal deflector blades are open a minimum of 30° as measured from vertical.

Lighting Instructions (Also on Unit)

- Turn off power. Turn thermostat down. Move gas control knob (or lever) to OFF and wait 5 minutes.
- Move gas control knob (or lever) to ON.
- Set thermostat at desired setting. (Pilot and main burner will light automatically when thermostat calls for heat).

Shut Down Instructions

Turn off power and close manual gas valve.

After Initial Start Up

- Check pilot flame adjustment as discussed below.
- Check gas piping for leaks with a soap bubble solution to insure safe operation.
- Check gas input rate, as described below, to assure proper gas flow and pressure.

Pilot Flame Adjustment

The pilot is orificed to burn properly with an inlet pressure of 6-7" W.C. on natural gas and 11-14" W.C. on propane gas, but final adjustment must be made after installation. Adjust to have a soft steady flame 3/4" to 1" long and encompassing 3/8"-1/2" of the tip of the thermocouple or flame sensing rod. Normally this flame will produce satisfactory results. To adjust the flame use pilot adjustment screw on combination gas control (for location, see the combination gas control literature supplied with unit). If the pilot flame is longer and larger than shown by Figure 7, it is possible that it may cause soot and/or impinge on the heat exchanger causing burnout. If the pilot flame is shorter than shown it may cause poor ignition and result in the controls not opening the combination gas control. A short flame can be caused by a dirty pilot orifice. Pilot flame conditions should be observed periodically to assure trouble-free operation.

Natural Gas Flame Control

Control of burner flames on units utilizing natural gas is achieved by moving the gas manifold to either increase or decrease primary combustion air. Prior to flame adjustment, operate unit with casing closed for about five minutes. Operation can be viewed through the sight glass on the rear of the unit (see Figure 11a).

Lack of primary air will cause soft yellow-tipped flames. Excess primary air produces whort, well-defined flames with a tendency to lift off the burner ports. Proper operation with natural gas provides a soft blue flame with a well-defined inner cone.

To increase primary air, remove the access panel (see Figure 11a and 11b). Next loosen the fastening screws holding the hinged bottom pan in place and lower the bottom pan (see Figure 14). With the bottom pan lowered, loosen the manifold mounting screws (see Figure 14) and tap the manifold away from the mixer tubes until the yellow flames disappear. To decrease the primary air, move the manifold closer to the mixer tubes until flames no longer lift from burner ports, but being careful not to cause yellow tipping. Retighten manifold mounting screws after adjustment.

Once adjustment has been made all around the bottom pan. Replace the access panel, again checking for a good tight seal around the entire perimeter of the access panel. Observe the burner flame through the sight glass to make sure proper flame adjustment has been achieved.

Propane Gas Flame Control

Adjustable primary air shutters are attached to the orifices on the gas manifold for units equipped for propane gas operation (see Figure 15). An optimum flame will show a slight yellow tip. Prior to flame adjustment, operate unit heater with casing closed for at least five minutes. If flame adjustment is necessary, remove the access panel (see Figure 11a and 11b) and adjust primary air shutters. Loosen wing screws and push shutters forward to reduce primary air until yellow flame tips appear. Then increase primary air until yellow tips diminish to just a slight yellow tip and a clean blue flame with a well-defined inner cone appears.

It may also be necessary to adjust the manifold position in addition to adjusting air shutters to obtain the proper flame. Follow the instructions under "Natural Gas Flame Control" for adjusting the manifold.

Replace the access panel making sure a good tight seal is achieved around the entire perimeter of the access panel. Observe the burner flame through the sight glass to make sure proper flame adjustment has been achieved.

CHECKING INPUT RATE

Input Adjustments

The gas pressure regulator (part of the combination gas control) is adjusted at the factory for average gas conditions. It is important that gas be supplied to the heater in accordance with the input rating stamped on the serial plate. Actual input rating stamped on the serial plate. Actual input should be checked and necessary adjustments made after the heater is installed. Over-firing, a result of too high an input, reduces the life of the unit, and increases maintenance. Under no circumstances should the input exceed that shown on the rating plate.

(A) Meter Timing Method

1. Shut off all other gas-burning equipment, including other pilot lights served by the gas meter.
2. Start the heater and determine the number of seconds it takes to consume 1 cu. ft. of gas. Two basic formulas are useful:

$$F1 = 3600 C/T$$
$$F2 = F1/C$$

Where

F1 = input to heater, Btuh.
F2 = input to heater, cu. ft. per hr.
C = heating value of gas, Btu per cu. ft.
T = time to consume 1 cu. ft. of gas in sec.

The heating value of gas may be determined from the local utility or gas dealer.

These are representative values:

<u>GAS</u>	<u>Btu per cu. ft.</u>
Natural	1000-1150
Propane	2500

3. If the seconds for 1 cu. ft. are more (input less) than shown in Table 5 for model being tested, remove the access panel (see Figure 11a). With access panel removed, locate the combination gas control and pressure regulator adjustment screw (see Figure 11b). Remove the cap screw from the pressure regulator and take one clockwise turn at a time on the adjustment screw until the correct time is obtained. If the seconds are less (input greater) than indicated in the table, follow the same procedure in a **counter-clockwise** direction.

If the correct number of seconds cannot be obtained check orifice size. Correct orifices can be obtained from Modine Manufacturing Company, Racine, Wisconsin. When requesting orifices, state type of gas, heating value, and its specific gravity. Also give model number of unit.

For example, if the input to the heater is 100,000 Btuh and the heating value of the gas is 1000 Btu per cu. ft., then, by the second formula, the input is 100 cu. ft. per hr. Table 4 indicates the time for one revolution of various size meter dials with various input rates. If a 1 cu. ft. meter dial is used, we proceed down the cu. ft. column to 100 cu. ft. per hr. and then horizontally to the left to determine a time of 36 seconds for one revolution of the dial. Similarly, if the 1/2 cu. ft. dial is used, we determine a time of 18 seconds for one revolution at the required input.

After proper firing rate has been achieved, replace regulator cap crew and replace access panel, making sure a good tight seal is achieved around the entire perimeter of the access panel.

CHECKING INPUT RATE

Table 4

Time for 1 Revolution, Sec.	Input, Cu. Ft. per Hour, When Meter Dial Size is:			
	1/2 cu. ft.	1 cu. ft.	2 cu. ft.	5 cu. ft.
10	180	360	720	1800
12	150	300	600	1500
14	129	257	514	1286
16	112	225	450	1125
18	100	200	400	1000
20	90	180	360	900
22	82	164	327	818
24	75	150	300	750
26	69	138	277	692
28	64	129	257	643
30	60	120	240	600
35	51	103	206	514
40	45	90	180	450
45	40	80	160	400
50	36	72	144	360
55	33	65	131	327
60	30	60	120	300
70	26	51	103	257
80	22	45	90	225
90	20	40	80	200
100	18	36	72	180
120	15	30	60	150

Meter-Timing Gas

(Time required for one revolution is charted for various size meter dials and various rates of gas input in cu. ft. per hour. To convert to Btuh, multiply by the heating value of the gas used.)

Figure 10
Dials of Typical Gas Meter



(B) Pressure Method

The pressure method determines input by measuring the pressure of the gas in the manifold in inches of water.

1. Determine correct manifold pressure from Table 5.
2. Remove access panel (see Figure 11a) and locate combination gas control.
3. Move gas control knob (or lever) to off.
4. Remove the 1/8" pipe plug in outlet pressure tap in combination gas control (see Figure 11b) and attach water manometer or "U" tube which is at least 12" high.
5. Follow lighting instructions and turn thermostat up to get unit to fire.

! CAUTION

Check the gas inlet pressure at the unit upstream of the combination gas control. The inlet pressure should be 6"-7" W.C. on natural gas or 11"-14" W.C. on propane. If inlet pressure is too high, install an additional pressure regulator upstream of the combination gas control.

Important —Inlet pressure and manifold pressure must be checked with unit in operation when making final adjustments.

6. If pressure as indicated by "U" tube is less than 1/2" higher or lower than indicated in Table 5, adjust regulator as described under "meter-Timing method," Step 3.

If pressure as indicated by "U" tube is more than 1/2" higher or lower than indicated in Table 5, check inlet pressure at unit. The inlet pressure should be 6"-7" W.C. pressure on natural gas and 11"-14" W.C. on propane gas.

After adjustment move gas control knob (or level) to off and replace 1/8" pipe plug. With plug in place move knob (or leave) to on.) Replace the access panel, making use a good tight seal is achieved around the entire perimeter of the access panel.

Figure 11a

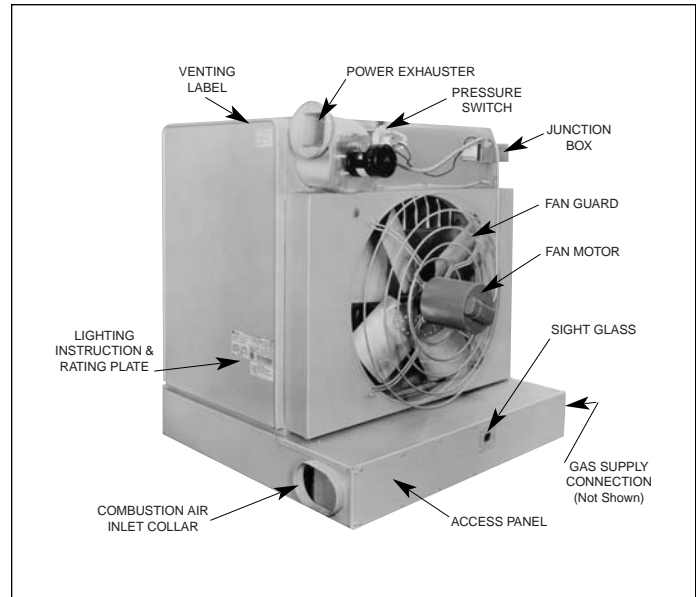
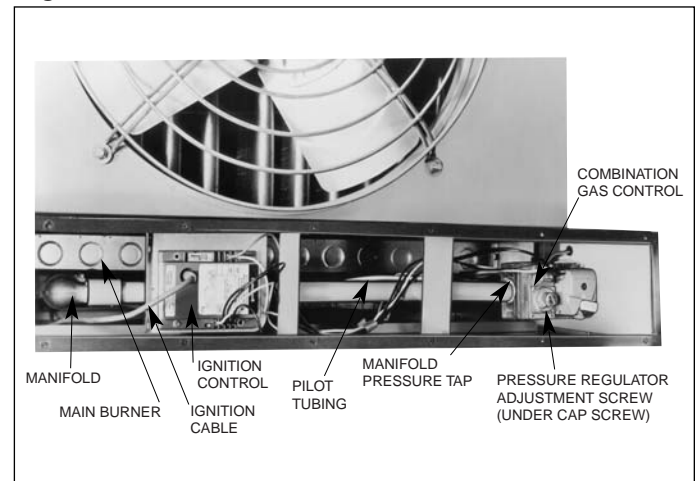

Figure 11b



CHECKING INPUT RATE

Table 5
Manifold Pressure & Gas Consumption^①

Model	Typical Heating Value (BTU/Cu.Ft.) Specific Gravity	Natural	Propane	No. of Orifices
		1040 0.60	2500 1.53	
Manifold Pressure inches w.c.		3.5	10.0	
PSH130 BSH130	Cfh	125	52	2
	Gal/Hr. Propane	—	1.42	
	Sec/cu.ft.	29	69	
	Orifice Drill Size	24	41	
PSH150 BSH150	Cfh	144	60	3
	Gal/Hr. Propane	—	1.64	
	Sec/cu.ft.	25	60	
	Orifice Drill Size	29	44	
PSH170 BSH170	Cfh	163	68	3
	Gal/Hr. Propane	—	1.86	
	Sec/cu. ft.	25	60	
	Orifice Drill Size	27	43	
PSH225 BSH225	Cfh	216	90	3
	Gal/Hr. Propane	—	2.46	
	Sec/cu.ft.	17	40	
	Orifice Drill Size	19	37	
PSH280 BSH280	Cfh	269	112	4
	Gal/Hr. Propane	—	3.06	
	Sec/cu. ft.	13	32	
	Orifice Drill Size	21	39	
PSH340 BSH340	Cfh	327	136	5
	Gal/Hr. Propane	—	3.72	
	Sec/cu. ft.	11	26	
	Orifice Drill Size	22	40	

^① Above gases based on average standards. Units can be furnished for gases of different values and specific gravities. (Gas/Hr. Propane based on 60°F, 30" Hg, 91,500 Btu/Gal.

Table 6
Orifice Drill sizes with Decimal Equivalents
Main Burner Orifices

Drill Size	Dia. Decimal Equivalent	Drill Size	Dia. Decimal Equivalent
19	.1660	37	.1040
21	.1590	39	.0995
22	.1570	40	.0980
24	.1520	41	.0960
27	.1440	43	.0890
29	.1360	44	.0860

Pilot Orifice Identity Numbers

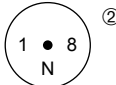
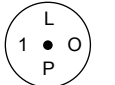
Pilot Burner Manufacturer	Identity No. Natural Gas	Identity No. Propane Gas
Honeywell	BCR-18	BCR-11 or -12
Robertshaw	 ^②	 ^②
Johnson	7715	4710

^② As number appears on top of pilot orifice.

SEPARATED COMBUSTION PROPELLER UNIT HEATERS

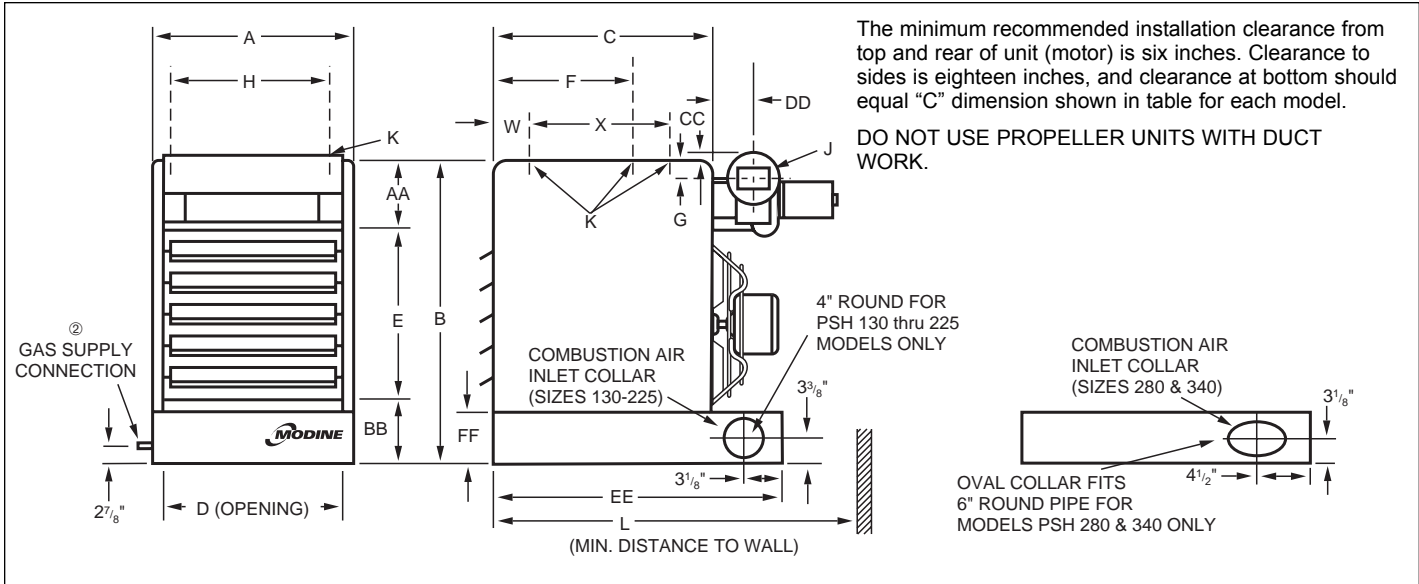

Dimensions (in inches) — PSH

Dimension	PSH 130	PSH 150	PSH 170	PSH 225	PSH 280	PSH 340
A	23-1/2	25-5/8	25-5/8	28-5/8	33-5/8	40
B	35-1/2	40-1/2	40-1/2	40-1/2	40-1/2	40-1/2
C	22	25	25	25	25	25
D	21-1/16	23-3/16	23-3/16	26-3/16	31-3/16	37-1/2
E	20	24	24	24	24	24
F	12-1/2	14-1/2	14-1/2	14-1/2	—	—
G	1	2	2	2	1-5/8	1-5/8
H	19-7/8	22	22	25	30	36-3/8
AA	8	9	9	9	9	9
BB	7 1/2	7-1/2	7-1/2	7-1/2	7-1/2	7-1/2
CC	1	1/8	1/8	1/8	1-3/8	1-3/8
DD	3-1/4	3-1/4	3-1/4	3-1/4	3-5/8	3-5/8
EE	32-9/16	36	36	36	36-1/16	36-1/16
FF	6-1/2	6-1/2	6-1/2	6-1/2	5-7/8	5-7/8
J (Round)	4	4	4	4	6	6
K ①	3/8-16	3/8-16	3/8-16	3/8-16	3/8-16	3/8-16
Natural Gas Connections ③	1/2	1/2	1/2	1/2	3/4	3/4
W	—	—	—	—	5	5
X	—	—	—	—	16	16
L	38-3/8	42	42	42	42	48
Fan Diameters	18	20	20	22	22	24
Approx. Ship. Wt.	198	244	246	272	328	422

① PSH 130 through PSH 225 — 2 holes.

PSH 280 & PSH 340 — 4 holes.

② Dimension from rear of unit burner box to center line of gas pipe connection is 6-23/32" for PSH 130 and 6-1/2" for all other models.

③ For natural gas.

Performance—PSH

Model	Btu/Hr Input ⑤	Btu/Hr Output	CFM @ 70°F	Outlet Velocity	Air Temp. Rise	Max. Mtg. Height (Ft.) ④	Heat Throw (Ft.) ④	Standard Motor Data ⑥			
								HP	Amps	RPM	Type
PSH 130	130,000	106,600	2540	940	39	12	50	1/6	2.8	1075	PSC
PSH 150	150,000	123,000	2900	810	39	16	50	1/6	2.8	1075	PSC
PSH 170	170,000	139,400	2900	820	45	16	50	1/6	2.8	1075	PSC
PSH 225	225,000	184,000	4275	1060	40	20	65	1/3	5.4	1075	PSC
PSH 280	280,000	229,600	4400	960	48	20	65	1/2	6.8	1075	PSC
PSH 340	340,000	275,400	5300	980	48	20	65	1/2	6.8	1075	PSC

④ At 65°F ambient and unit fired at full rated input. Max mounting height as measured from bottom of unit, and without deflector hoods.

⑤ Note: Ratings shown are for elevations up to 2,000 feet. For elevations above 2,000 feet, ratings should be reduced at the rate of 4% for each 1,000 feet above sea level. (In Canada see Rating Plate.) Reduction of ratings requires use of high altitude kit.

⑥ Data listed is for standard 115-volt, 60-Hertz, single-phase motors. All single phase motors are totally enclosed and thermal overload protected.

SEPARATED COMBUSTION BLOWER UNIT HEATERS

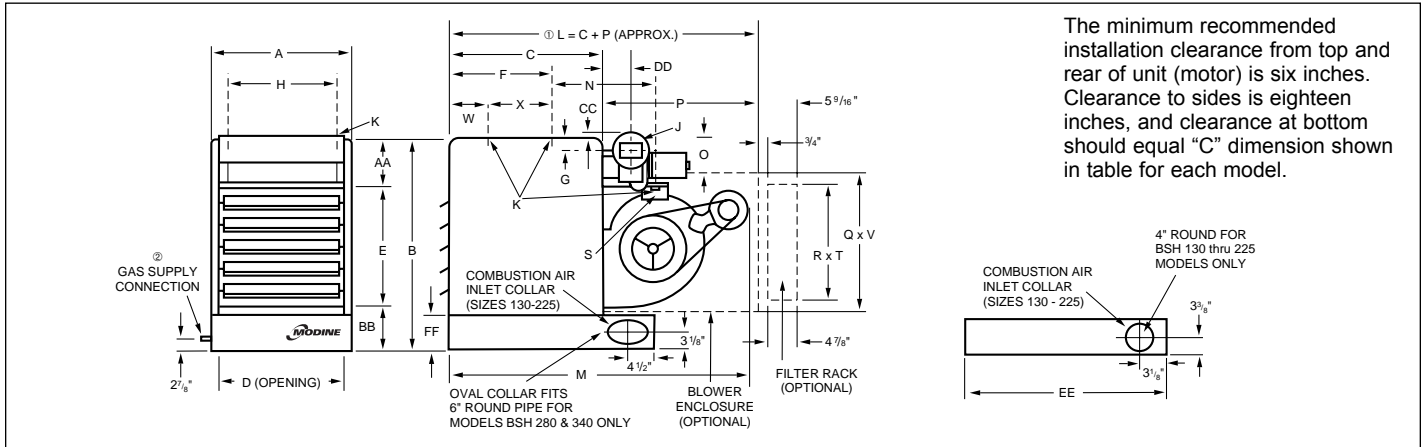

The minimum recommended installation clearance from top and rear of unit (motor) is six inches. Clearance to sides is eighteen inches, and clearance at bottom should equal "C" dimension shown in table for each model.

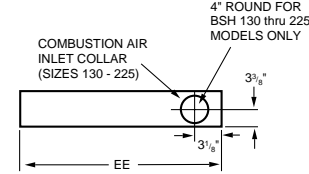

Dimensions (in inches) — BSH

Dimension	BSH 130	BSH 150	BSH 170	BSH 225	BSH 280	BSH 340	
A	23-1/2	25-5/8	25-5/8	25-5/8	33-5/8	40	
B	35-1/2	40-1/2	40-1/2	40-1/2	40-1/2	40-1/2	
C	22	25	25	25	25	25	
D	21-1/16	23-3/16	23-3/16	26-3/16	31-3/16	37-1/2	
E	20	24	24	24	24	24	
F	12-1/2	14-1/2	14-1/2	14-1/2	—	—	
G	1	2	2	2	1-5/8	1-5/8	
H	19-7/8	22	22	25	30	36-3/8	
AA	8	9	9	9	9	9	
BB	7-1/2	7-1/2	7-1/2	7-1/2	7-1/2	7-1/2	
CC	1	1/8	1/8	1/8	1 3/8	1 3/8	
DD	3-1/4	3-1/4	3-1/4	3-1/4	3-5/8	3-5/8	
EE	32-9/16	36	36	36	36-1/16	36-1/16	
FF	6-1/2	6-1/2	6-1/2	6-1/2	5-7/8	5-7/8	
J (Round)	4	4	4	4	6	6	
K ③	3/8-16	3/8-16	3/8-16	3/8-16	3/8-16	3/8-16	
Natural Gas Connections	1/2	1/2	1/2	1/2	3/4	3/4	
W	—	—	—	—	5	5	
X	—	—	—	—	16	16	
M	47-3/4	52-3/8	52-3/8	52-3/8	52-3/8	58-1/2	
N ④	21	24-1/2	24-1/2	24-1/2	17-15/16	22-1/16	
O	7-1/4	8-1/2	8-1/2	8-1/2	8-1/2	8-1/2	
Blower Enclosure (Accessory)	P	30	34	34	36	36	
	Q (Height)	21-3/8	25	25	25	25	
	Inlet Duct/R (Height)	20	23-3/4	23-5/8	23-5/8	23-5/8	23-5/8
	Filter Rack Width T	27-1/2	32-3/4	32-3/4	32-3/4	42-7/8	42-7/8
Width V	29	34	34	34	44-1/4	44-1/4	
S (Ctr. to Ctr. of Blower Mtg. Holes)	17-3/8	20-3/8	20-3/8	20-3/8	20-3/8	20-3/8	
Motor Pulley Diameter ⑤	3	3	3	3	3	3	
Standard Blower Pulley Diameter	13	13	13	13	9	9	
Approx. Shipping Weight	240	322	322	344	436	510	

- ① On blower units L = C + P is distance from front of unit to back of blower enclosure and minimum of distance to wall.
- ② Dimension from rear of unit burner box to center line of gas pipe connection is 6-23/32" for BSH 130 and 6-1/2" for all other models.
- ③ BSH 130 through BSH 225 – 4 holes. BSH 280 and BSH 340 – 6 holes.
- ④ Distance between mounting hole in unit casing and mounting hole on blower, except on 280 and 340, then distance from rear mounting hole in casing.
- ⑤ Motor pulley is adjustable.

Note: Mounting heights and throws for BSH models, without ductwork or nozzles, and at a cfm yielding a 55°F temperature rise are the same as those listed for equivalent size PSH units.

Performance — BSH

Model	Btu/Hr Input ⑦	Btu/Hr Output	CFM @ 55°F Temp. Rise	Outlet Velocity @ 55°F Temp. Rise	CFM Range	Air Temp. Rise Range	Max. Mtg. Height (Ft.) @ 55°F Temp. Rise ⑥	Heat Throw (Ft.) @ 55°F Temp. Rise ⑥	Standard Motor Data ⑧			
									HP	Amps	RPM	Type
BSH 130	130,000	106,600	1795	682	1161-1795	55-85	11	30	1/4	5.4	1725	SP
BSH 150	150,000	123,000	2071	596	1340-2071	55-85	10	25	1/2	7.8	1725	SP
BSH 170	170,000	139,400	2347	675	1519-2347	55-85	11	30	1/2	7.8	1725	SP
BSH 225	225,000	182,250	3068	781	1985-3068	55-85	13	35	3/4	10.2	1725	SP
BSH 280	280,000	229,600	3865	852	2501-3865	55-85	14	40	1	13.2	1725	CP
BSH 340	340,000	275,400	4636	869	3000-4636	55-85	15	40	1	13.2	1725	CP

- ⑥ At 65°F ambient and unit fired at full rated input. Max mounting height as measured from bottom of unit, and without deflector hoods.
- ⑦ Note: Ratings shown are for elevations up to 2,000 feet. For elevations above 2,000 feet, ratings should be reduced at the rate of 4% for each 1,000 feet above sea level. (In Canada see Rating Plate.) Reduction of ratings requires use of high altitude kit.
- ⑧ Data listed is for standard 115-volt, 60-Hertz, single-phase motors. All single phase motors are totally enclosed and thermal overload protected.

PERFORMANCE DATA — BLOWER UNIT HEATERS

Blower Models With or Without Blower Enclosures ① ②

Model Number	Air Flow CFM	Outlet Velocity FPM	Air Temp. Rise F	0.0 Static Pressure				0.1 Static Pressure				0.2 Static Pressure				0.3 Static Pressure				0.4 Static Pressure			
				RPM	HP	Drive No.	Pulley Turns Open	RPM	HP	Drive No.	Pulley Turns Open	RPM	HP	Drive No.	Pulley Turns Open	RPM	HP	Drive No.	Pulley Turns Open	RPM	HP	Drive No.	Pulley Turns Open
BSH 130	1795	682	55	385			0	460			1	520			1	570	—	—	—	620			2
	1645	630	60	355			1	435	1/3	-57	2	500			1-1/2	550	1/2	-96	3	605	1/2	-96	2
	1519	587	65	325			2	415			2-1/2	480			2	535			1/2	590			2.5
	1410	549	70	305	1/4	-97	3	395			3	465	1/3	-15	2-1/2	520	1/3	-15	1	580			2.5
	1316	517	75	285			3-1/2	380			0	450			3	510			1	570	1/3	-13	1-1/2
	1234	489	80	270			4-1/2	365	1/4	-97	1/2	440			3	500			1-1/2	560			1-1/2
	1161	464	85	250			5	350			1-1/2	430			3-1/2	490			2	550			2
BSH 150	2071	596	55	255	1/2	-25	5	330			2	390			0	445			0	500	3/4	-18	1-1/2
	1898	551	60	235	—	—	—	310			3	375			1/2	430			1/2	485			2
	1752	513	65	220	—	—	—	295			3-1/2	360			1	415	1/2	-22	1	475			2
	1627	480	70	205	—	—	—	280	1/2	-25	4	245	1/2	-25	1-1/2	405			1-1/2	470			2
	1519	452	75	190	—	—	—	270			4-1/2	335			2	395			2	460			2-1/2
	1424	427	80	180	—	—	—	260			4-1/2	325			2	390	1/2	-25	0	455	1/2	-22	0
	1340	405	85	170	—	—	—	250			5	315			2-1/2	380			0	450			0
BSH 170	2347	675	55	290			3-1/2	360			1	420	1/2	-22	1	470	3/4	-18	2	520			1
	2151	624	60	265	1/2	-25	4-1/2	335			2	400			1-1/2	455			0	505			1-1/2
	1986	581	65	245			5	305			2-1/2	385			0	440			1/2	495	3/4	-18	1-1/2
	1844	544	70	230	—	—	—	290	1/2	-25	3	370			1/2	425			1	485			2
	1721	512	75	215	—	—	—	280			3-1/2	355	1/2	-25	1	415			1	475			2
	1613	484	80	200	—	—	—	270			4	345			1-1/2	405	1/2	-22	1-1/2	465			2-1/2
	1519	459	85	190	—	—	—	250			4-1/2	335			2	395			2	460	1/2	-22	0
BSH 225	3068	781	55	385			0	440	3/4	-22	1/2	490			1-1/2	535			1/2	575	1	-16	1
	2813	722	60	345			1-1/2	415			1	465			2-1/2	510			1	555			0
	2596	672	65	315	3/4	-25	2-1/2	390			0	440	3/4	-18	3	485			2	535			1/2
	2411	630	70	285			3-1/2	365	3/4	-25	1/2	420			3-1/2	470	3/4	-18	2-1/2	520			1
	2250	592	75	260			4-1/2	350			1	405			4	455			2-1/2	510	3/4	-18	1
	2109	560	80	240	—	—	—	330			2	390	3/4	-25	0	440			3	495			1-1/2
	1985	531	85	220	—	—	—	315			2-1/2	375			1/2	425			3-1/2	485			2
BSH 280	3865	725	55	530			1/2	575	1-1/2	-23	3-1/2	615	1-1/2	-23	2-1/2	645			1-1/2	670	1-1/2	-23	1/2
	3543	670	60	490			1-1/2	535			1/2	580			3-1/2	615	1-1/2	-23	2-1/2	640			1-1/2
	3271	624	65	450			3	500			1-1/2	545			1/2	585			3-1/2	620			2
	3037	584	70	420	1	-18	3-1/2	470			2-1/2	520			1	565			0	595	1	-16	1/2
	2835	550	75	395			4	445	1	-18	3	495	1	-18	1-1/2	540	1	-18	1/2	580			1
	2657	519	80	370			5	425			3-1/2	475			2	525			1	560	1	-18	0
	2501	493	85	350	—	—	—	405			4	455			2-1/2	510			1	545			1/2
BSH 340	4636	869	55	610	1-1/2	-16	1/2	655	2	-32	1	690	2	-32	0	725	—	—	—	750	—	—	—
	4250	804	60	550			0	605	1-1/2	-16	1/2	645			1-1/2	685	2	-32	0	710	—	—	—
	3923	748	65	500			1-1/2	560			0	605	1-1/2	-16	1/2	645			1-1/2	680	2	-32	0
	3643	701	70	460			2-1/2	525			1	575			1	615			0	650			1
	3400	659	75	420	1	-219	3-1/2	490	1	-219	1-1/2	545			1/2	590	1-1/2	-16	1	625			0
	3188	623	80	390			4-1/2	465			2-1/2	520	1	-219	1	570			1-1/2	605	1-1/2	-16	1/2
	3000	591	85	360			5	440			3	500			1-1/2	550	1	-219	0	585			1

① Ratings shown are for elevations up to 2,000 feet. For elevations above 2,000 feet, ratings should be reduced at the rate of 4% for each 1,000 feet above sea level. (Does not apply in Canada — See Rating Plate.)

② Pulley turns open are approximate. For proper operation, check blower rpm.

Important: Note for 575V Only ③

Model Number	From this Catalog		For 575V ④	
	HP	Drive	HP	Drive
BSH130	1/3	-13	1/3	-14
	1/4	-97	1/4	-165
	1/3	-15	1/3	-166
	1/3	-57	1/4	-167
BSH280	1-1/2	-23	1-1/2	-177
BSH340	1-1/2	-16	1-1/2	-178

③ Models not shown use same HP and drive number as cataloged.

④ Performance is the same; motor sheave can accommodate larger shaft.

Blower Models With Filter ① ②

Model Number	Air Flow CFM	Outlet Velocity FPM	Air Temp. Rise F	0.0 Static Pressure				0.1 Static Pressure				0.2 Static Pressure				0.3 Static Pressure				0.4 Static Pressure			
				RPM	HP	Drive No.	Pulley Turns Open	RPM	HP	Drive No.	Pulley Turns Open	RPM	HP	Drive No.	Pulley Turns Open	RPM	HP	Drive No.	Pulley Turns Open	RPM	HP	Drive No.	Pulley Turns Open
BSH 130	1795	682	55	445	1/3	-57	1-1/2	520	1/3	-15	1	575	—	—	—	615	—	—	—	660	—	—	—
	1645	630	60	410			2-1/2	485			1/2	545			1/2	595	—	—	—	640	—	—	—
	1519	587	65	375			1/2	460			1	520			1	575	—	—	—	625			2
	1410	549	70	345			1-1/2	435	1/3	-57	2	500	1/3	-15	1-1/2	560			0	610	1/2	-96	2
	1316	517	75	325	1/4	-97	2	415			2-1/2	480			2	545			1/2	600			2
	1234	489	80	300			3	395			3	460			2-1/2	535	1/3	-15	1/2	585	1/3	-13	1
	1161	464	85	285			3-1/2	380	1/4	-97	0	450			3	525			1	575			1
BSH 150	2071	596	55	285	1/2	-25	3-1/2	350			1	415	1/2	-22	1	460			0	530			1/2
	1898	551	60	260			4-1/2	325			2	395			2	445			0	515			1
	1752	513	65	235	—	—	—	305			3	380			0	430	1/2	-22	1/2	505			1-1/2
	1627	480	70	220	—	—	—	290	1/2	-25	3-1/2	365			1/2	420			1	495	3/4	-18	1-1/2
	1519	452	75	205	—	—	—	280			4	355	1/2	-25	1	405			1-1/2	485			2
	1424	427	80	190	—	—	—	265			4 1/2	345			1-1/2	400			1-1/2	480			2
	1340	405	85	180	—	—	—	255			5	335			2	390	1/2	-25	0	475			2
BSH 170	2347	675	55	325			2	385			0	445			0	490	3/4	-18	1-1/2	550			0
	2151	624	60	295	1/2	-25	3-1/2	360			1	425	1/2	-22	1	470			2	535			1/2
	1986	581	65	270			4-1/2	340			1-1/2	405			1-1/2	455			0	520	3/4	-18	1
	1844	544	70	250			5	320	1/2	-25	2-1/2	390			0	440			1/2	510			1
	1721	512	75	235	—	—	—	305			3	375	1/2	-25	1/2	425	1/2	-22	1	500			1-1/2
	1613	484	80	215	—	—	—	290			3-1/2	365			1/2	415			1	495			1-1/2
	1519	459	85	205	—	—	—	275			4	355			1	405			1-1/2	485			2
BSH 225	3068	781	55	465	3/4	-18	2 1/2	515			1	550			0	600	1	-16	1/2	635			0
	2813	722	60	420			3 1/2	485			2	515			1	565			1-1/2	610	1	-16	1/2
	2596	672	65	385			0	455			2-1/2	490			1 1/2	540			1/2	590			1
	2411	630	70	350			1	430	3/4	-18	3-1/2	465	3/4	-18	2 1/2	515			1	575			1
	2250	592	75	325	3/4	-25	2	410			4	440			3	495	3/4	-18	1-1/2	560			0
	2109	560	80	300			3	390			4-1/2	425			3-1/2	480			2	545	3/4	-18	1/2
	1985	531	85	280			4	375	3/4	-25	1/2	405			4	465			2-1/4	535			1/2
BSH 280	3865	725	55	595	1-1/2	-23	3	645			1-1/2	680	1-1/2	-23	0	705	—	—	—	725	—	—	—
	3543	670	60	545			1/2	600	1-1/2	-23	3	640			1-1/2	665	1-1/2	-23	1/2	690			0
	3271	624	65	505			1 1/2	565			4	605	1	-16	1/2	635			1-1/2	660	1-1/2	-23	1
	3037	584	70	470			2 1/2	530			1/2	575			1	610			1/2	635			1-1/2
	2835	550	75	440	1	-18	3	500	1	-18	1-1/2	550			0	585	1	-16	1	615			0
	2657	519	80	415			3 1/2	475			2	525	1	-18	1	565			1-1/2	595	1	-16	1/2
	2501	493	85	390			4 1/2	455			2-1/2	505			1-1/2	545	1	-18	1/2	580			1
BSH 340	4636	869	55	685	2	-32	0	715	—	—	—	740	—	—	—	765	—	—	—	795	—	—	—
	4250	804	60	615	1-1/2	-16	0	655	2	-32	1	685	2	-32	0	720	—	—	—	745	—	—	—
	3923	748	65	560			0	605	1-1/2	-16	1/2	640			1-1/2	680	2	-32	0	705	—	—	—
	3643	701	70	515			1	560			0	600	1-1/2	-16	1/2	645			1-1/2	670	2	-32	1/2
	3400	659	75	470	1	-219	2	525	1	-219	1	570			1-1/2	615			0	640			1-1/2
	3188	623	80	435			3	490			1-1/2	540	1	-219	1/2	590	1-1/2	-16	1	615	1-1/2	-16	0
	3000	591	85	405			4	465			2-1/2	515			1	565			1-1/2	595			1/2

① Ratings shown are for elevations up to 2,000 feet. For elevations above 2,000 feet, ratings should be reduced at the rate of 4% for each 1,000 feet above sea level. (Does not apply in Canada — See Rating Plate.)

② Pulley turns open are approximate. For proper operation, check blower rpm.

Important: Note for 575V Only ③

Model Number	From this Catalog		For 575V ④	
	HP	Drive	HP	Drive
BSH130	1/3	-13	1/3	-14
	1/4	-97	1/4	-165
	1/3	-15	1/3	-166
	1/3	-57	1/4	-167
BSH280	1-1/2	-23	1-1/2	-177
BSH340	1-1/2	-16	1-1/2	-178

③ Models not shown use same HP and drive number as cataloged.

④ Performance is the same; motor sheave can accommodate larger shaft.

MOTOR DATA

Power Code Description — PSH Models ① ③ ④

Power Code	Model Electric Power	PSH130	PSH150	PSH170	PSH225	PSH280	PSH340
		Horsepower					
01	115/60/1	1/6	1/6	1/6	1/3	1/2	1/2
02	230/60/1	1/6	1/6	1/6	1/3	1/2	1/2
04	200/60/3	1/3	1/3	1/3	1/3	1/2	1/2
05	200/460/60/3	1/3	1/3	1/3	1/3	1/2	1/2

Motor Data and Total Unit Power Requirements — PSH Models

Voltage	115/60/1				230/60/1				200-208/60/3				230/460/3				
	HP	Motor Amps	Motor Rpm	Total Amps	Total Watts	Motor Amps	Motor Rpm	Total Amps	Total Watts	Motor Amps	Motor Rpm	Total Amps	Total Watts	Motor Amps	Motor Rpm	Total Amps	Total Watts
1/6	2.8	1075	4.6	400	1.5	1075	2.5	400									
1/3	5.4	1075	7.2	610	2.5	1075	3.5	610	1.9	1140	2.8	560	2.2/1.1	1140	3.2/1.6	560	
1/2	7.5	1075	9.3	800	3.5	1075	4.5	800	2.6	1140	3.5	850	3.0/1.5	1140	4.0/2.0	850	

Power Code Description — BSH Models ② ③ ④ ⑤

Power Code	Model Electric Power	BSH130		BSH150		BSH170		BSH225		BSH280		BSH340	
		HP	Drive	HP	Drive	HP	Drive	HP	Drive	HP	Drive	HP	Drive
01	115/60/1	1/3	-13	3/4	-18	3/4	-18	3/4	-18	1	-16	1-1/2	-16
02	230/60/1	1/3	-13	3/4	-18	3/4	-18	3/4	-18	1	-16	1-1/2	-16
03	200-208/60/3	1/3	-13	3/4	-18	3/4	-18	3/4	-18	1	-16	1-1/2	-16
04	230/460/60/3	1/3	-13	3/4	-18	3/4	-18	3/4	-18	1	-16	1-1/2	-16
81	575/60/3	1/3	-14	3/4	-18	3/4	-18	3/4	-18	1	-16	1-1/2	-178
05	115/60/1	1/4	-97	1/2	-25	1/2	-25	3/4	-22	1	-18	1	-29
06	230/60/1	1/4	-97	1/2	-25	1/2	-25	3/4	-22	1	-18	1	-29
07	200-208/60/3	1/4	-97	1/2	-25	1/2	-25	3/4	-22	1	-18	1	-29
08	230/460/60/3	1/4	-97	1/2	-25	1/2	-25	3/4	-22	1	-18	1	-29
82	575/60/3	1/4	-165	1/2	-25	1/2	-25	3/4	-22	1	-18	1	-29
09	115/60/1	1/3	-15	1/2	-22	1/2	-22	1	-16	1-1/2	-23		
10	230/60/1	1/3	-15	1/2	-22	1/2	-22	1	-16	1-1/2	-23		
11	200-208/60/3	1/3	-15	1/2	-22	1/2	-22	1	-16	1-1/2	-23	2	-32
12	230/460/60/3	1/3	-15	1/2	-22	1/2	-22	1	-16	1-1/2	-23	2	-32
83	575/60/3	1/3	-166	1/2	-22	1/2	-22	1	-16	1-1/2	-177	2	-32
13	115/60/1	1/3	-57	1/2	-18	1/2	-18	3/4	-25			1	-16
14	230/60/1	1/3	-57	1/2	-18	1/2	-18	3/4	-25			1	-16
15	200-208/60/3	1/3	-57	1/2	-18	1/2	-18	3/4	-25			1	-16
16	230/460/60/3	1/3	-57	1/2	-18	1/2	-18	3/4	-25			1	-16
84	575/60/3	1/3	-167	1/2	-18	1/2	-18	3/4	-25			1	-16
17	115/60/1	1/2	-96									1-1/2	-156
18	230/60/1	1/2	-96									1-1/2	-156
19	200-208/60/3	1/2	-96									1-1/2	-156
20	200/460/60/3	1/2	-96									1-1/2	-156
85	575/60/3	1/2	-96									1-1/2	-157

Unit Power Requirements - Blower BSH Models

HP	Voltage									
	115/60/1		230/60/1		200-208/60/3		230/460/60/3		575/60/3 ⑤	
	Total Amps	Total Watts	Total Amps	Total Watts	Total Amps	Total Watts	Total Amps	Total Watts	Total Amps	Total Watts
1/4	7.2	520	3.7	520	2.5	500	2.4/1.2	500	0.9	500
1/3	6.4	515	3.3	515	2.7	530	2.6/1.3	530	1.1	530
1/2	10.3	730	4.8	730	3.4	730	3.6/1.8	730	1.3	730
3/4	12.8	1000	6.5	1000	4.1	970	3.8/1.9	970	1.5	970
1	15.2	1210	7.7	1210	4.9	1230	4.8/2.4	1230	1.9	1230
1-1/2	16.8	1690	8.5	1690	6.5	1630	6.2/3.1	1630	2.3	1630
2	-	-	-	-	8.6	2080	7.6/3.8	2080	2.7	2080

① Permanent split capacitor motors on models PSH130 through PSH340.

② Split phase motors for 1/4 through 3/4 hp motors. Capacitor start motors are 1 through 2 hp.

③ Whenever 230V/1 ϕ or 230V/3 ϕ power is used, it is necessary to specify 230V/25V controls. Whenever 460V/3 ϕ power is used, it is necessary to specify 230V/25V controls and in addition, a 460V/230V 75VA step-down transformer (by others) is required. On 230V/3 ϕ or 460V/3 ϕ systems, the motor starter coil voltage (motor starter by others) must be 230V. For 200V/3 ϕ systems, the motor starter coil voltage (motor starter by others) must be 200V.

④ All motors used are produced, rated and tested by reputable manufacturers in accordance with NEMA standards and carry the standard warranty of both the motor manufacturer and Modine. All motors are totally enclosed. Single phase motors have built-in thermal overload protection.

⑤ 575V motor available on blower units only.

MOTOR DATA

Blower Drive Numbers

Sheave Drive No.	Belt No. Browning	Blower Sheave		Motor		Sheave Drive No.	Belt No. Browning	Blower Sheave		Motor	
		Pitch Dia.	Bore	Min/Max Pitch Dia.	Bore			Pitch Dia.	Bore	Min/Max Pitch Dia.	Bore
13	A43	8	0.750	1.9/2.9	0.500	32	A55	11	1.000	3.4/4.4	0.875
14	A44	8	0.750	1.9/2.9	0.625	57	A46	10	0.750	1.9/2.9	0.500
15	A44	9	0.750	1.9/2.9	0.500	97	A53	13	0.750	1.9/2.9	0.500
16	A48	8	1.000	1.9/2.9	0.625	165	A53	13	0.750	1.9/2.9	0.625
18	A49	9	1.000	1.9/2.9	0.625	166	A45	9	0.750	1.9/2.9	0.625
21	A52	13	0.750	1.9/2.9	0.500	167	A47	10	0.750	1.9/2.9	0.625
22	A53	11	1.000	1.9/2.9	0.625	177	A56	11	1.000	3.4/4.4	0.875
23	A56	11	1.000	3.4/4.4	0.625	178	A48	8	1.000	1.9/2.9	0.875
25	A58	13	1.000	1.9/2.9	0.625						

CONTROL OPTIONS

Propeller and Blower Unit Heaters — PSH and BSH Models ① ② ③ ④

Control System Description	Control Code No.	Service Voltage	Thermostat Voltage	Type of Gas
Single-Stage, Intermittent Pilot Ignition, 100% Shut-off with Continuous Retry — Utilizes a single-stage combination gas control and an ignition control (continuous retry). Pilot is automatically lit on call for heat.	30	115V	25V	natural
	31	200-208/230V	25V	natural
	③ 32	460V	25V	natural
	③ ④ 33	575V	25V	natural
	85	115V	25V	propane
	86	200-208/230V	25V	propane
	③ 93	460v	25V	propane
	③ ④ 94	575v	25V	propane

- ① Shaded prices - Standard units in stock; all others 2-3 weeks delivery.
- ② Stainless steel burner option - see page 5 for part number and list price.
- ③ CGA approved 460V and 575V available on blower units only.
- ④ 575V motor available on blower units only.

Control Operating Sequence

Upon a call for heat from the thermostat, power is supplied to the time delay relay for the power exhaustor motor. The power exhaustor motor will come on in 1 to 25 seconds. In 45 to 90 seconds (from the call for heat) the ignition control will be turned on. This delay allows for a pre-purge of the unit and the vent. Sparking will start at the igniter at the same time the first operator of the combination gas control opens to allow gas to flow to the pilot burner. The pilot flame should light and be sensed (proven) in a few seconds. As soon as the pilot flame is sensed the sparking will stop and the second operator of the combination gas control will open to allow gas to flow to the main burner. In 10 to 45 seconds from the time the ignition control was energized (1 to 2 minutes from the call for heat from the thermostat) the fan motor will start.

On units with control codes 08 and 09, when the ignition control is turned on it will attempt to light the pilot flame. If the pilot flame is not sensed for any reason, the sparking will continue indefinitely until the pilot flame is sensed or until power is interrupted to the ignition control. On units with control codes 30, 31, 85 and 86, the sequence is similar, except that when the

ignition control is turned on it will attempt to light the pilot flame for 70 seconds. If the pilot flame is not sensed for any reason, the ignition control will wait for a predetermined time with the combination gas control closed and no sparking. After the pre-determined time lapses, the cycle will begin again. The time that lapses between cycles is at preprogrammed intervals (approximately 6 minutes). This will continue indefinitely until the pilot flame is sensed or until power is interrupted to the ignition control.

When the thermostat has been satisfied, power is turned off to the ignition control (and therefore the combination gas control), so both the main gas and pilot gas are turned off. The fan motor will continue to operate for 20 to 60 seconds to allow the heat exchanger to cool down. Finally, the power exhaustor motor is turned off 1 to 2 minutes after the thermostat is satisfied. This allows the products of combustion to be cleared from the unit and the vent. The system is now ready for another call for heat from the thermostat.

PERFORMANCE DATA

30°, 60° and 90° Downward Deflector Hoods - Propeller PSH Models

Mounting Height to Bottom of Heater	30° Downward Deflector Hood		Propeller Models ^① (See Figures A and B)																	
			PSH 130			PSH 150			PSH 170			PSH 225			PSH 280			PSH 340		
			X	Y	Z	X	Y	Z	X	Y	Z	X	Y	Z	X	Y	Z	X	Y	Z
8'	21	44	60	19	39	53	17	37	50	26	53	73	21	43	59	22	46	62		
10'	20	43	59	17	38	52	16	35	48	25	53	72	20	42	58	21	56	61		
12'	19	42	58	16	37	50	15	34	46	24	52	70	18	41	56	10	43	59		
14'	18	41	56	15	35	48	13	32	44	23	50	69	17	39	65	18	42	57		
16'	16	38	53	13	32	44	11	28	39	21	49	67	15	37	51	17	40	55		
18'	14	36	50	10	28	39	7	20	29	20	47	64	14	34	47	15	37	52		
20'	21	31	44	8	23	33	—	—	—	18	44	61	11	29	41	13	33	47		
22'	8	24	35	—	—	—	—	—	—	16	41	58	8	23	34	8	24	36		

Mounting Height to Bottom of Heater	60° Downward Deflector Hood		Propeller Models ^① (See Figures A and B)																	
			PSH 130			PSH 150			PSH 170			PSH 225			PSH 280			PSH 340		
			X	Y	Z	X	Y	Z	X	Y	Z	X	Y	Z	X	Y	Z	X	Y	Z
8'	0	47	65	0	42	57	0	39	54	0	57	78	0	46	63	0	49	66		
10'	0	46	63	0	40	55	0	37	50	0	56	76	0	44	61	0	47	64		
12'	0	44	60	0	38	52	0	34	47	0	54	74	0	43	58	0	45	62		
14'	0	42	57	0	35	48	0	31	43	0	52	72	0	40	55	0	43	59		
16'	0	39	53	0	31	43	0	27	37	0	50	69	0	37	51	0	40	55		
18'	0	35	48	0	25	35	0	17	23	0	47	65	0	33	45	0	36	50		
20'	0	29	40	0	19	27	—	—	—	0	44	60	0	26	36	0	31	43		
22'	0	16	23	—	—	—	—	—	—	0	39	54	0	19	26	0	21	29		

Mounting Height to Bottom of Heater	90° Downward Deflector Hood		Propeller Models ^① (See Figures C and D)					
			PSH 130	PSH 150	PSH 170	PSH 225	PSH 280	PSH 340
			S	S	S	S	S	S
8'	56	50	46	77	59	65		
10'	50	45	41	69	53	59		
12'	46	41	37	63	48	53		
14'	43	38	35	58	45	50		
16'	40	35	32	54	42	46		
18'	38	33	31	51	40	44		
20'	36	32	29	49	38	42		
22'	34	30	28	46	36	40		
24'	—	—	—	45	34	38		

① Data based on units fired at full input rate and with an entering air temperature of 80° F.

30° and 60° Deflector Hoods — Propeller and Blower Models

Figure A

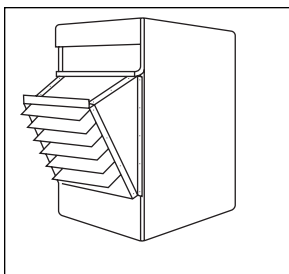

30° Hood

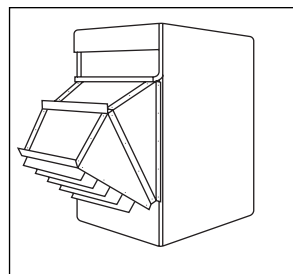

60° Hood

Figure B — Throw/Floor Coverage

Note:

O-X = Feet from heater to start of floor coverage.

O-Y = Feet to end of floor coverage.

O-Z = Feet to end of throw.

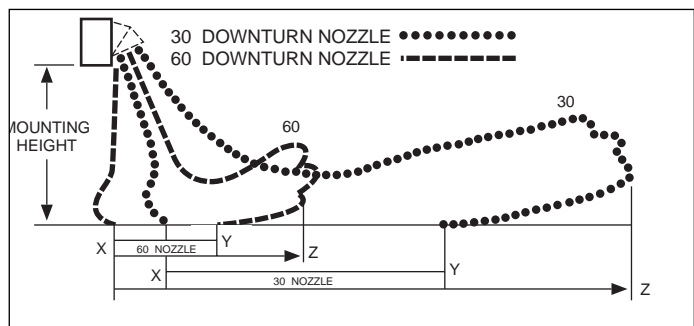

PERFORMANCE DATA

30°, 60° and 90° Downward Deflector Hoods - Propeller BSH Models

Mounting Height to Bottom of Heater	30° Downward Deflector Hood	Propeller Models ^① (See Figures A and B)																	
		BSH 130			BSH 150			BSH 170			BSH 225			BSH 280			BSH 340		
Model	X	Y	Z	X	Y	Z	X	Y	Z	X	Y	Z	X	Y	Z	X	Y	Z	
8'	11	25	34	9	22	30	11	25	35	14	31	43	16	35	48	17	37	50	
10'	9	22	31	8	19	26	10	23	32	13	30	41	15	34	44	15	34	48	
12'	7	19	26	6	16	23	8	20	28	12	28	38	14	32	44	15	34	46	
14'	5	15	21	4	13	19	6	16	23	10	24	34	12	29	41	13	23	44	
16'	—	—	—	—	—	—	—	—	—	8	22	31	10	25	36	11	28	40	
18'	—	—	—	—	—	—	—	—	—	6	18	26	8	22	31	10	26	36	
20'	—	—	—	—	—	—	—	—	—	—	—	—	—	—	—	7	20	29	

Mounting Height to Bottom of Heater	60° Downward Deflector Hood	Propeller Models ^① (See Figures A and B)																	
		BSH 130			BSH 150			BSH 170			BSH 225			BSH 280			BSH 340		
Model	X	Y	Z	X	Y	Z	X	Y	Z	X	Y	Z	X	Y	Z	X	Y	Z	
8'	0	25	35	0	22	30	0	26	36	0	33	45	0	37	50	0	39	53	
10'	0	22	30	0	18	25	0	23	32	0	31	42	0	35	48	0	37	51	
12'	0	17	23	0	9	13	0	18	25	0	27	38	0	32	44	0	35	47	
14'	0	10	14	—	—	—	0	13	19	0	23	32	0	29	40	0	31	43	
16'	—	—	—	—	—	—	—	—	—	0	12	17	0	23	32	0	27	37	
18'	—	—	—	—	—	—	—	—	—	—	—	—	0	18	26	0	17	24	
20'	—	—	—	—	—	—	—	—	—	—	—	—	0	13	19	0	14	19	

Mounting Height to Bottom of Heater	90° Downward Deflector Hood	Propeller Models ^① (See Figures C and D)											
		BSH 130		BSH 150		BSH 170		BSH 225		BSH 280		BSH 340	
Model	S	S	S	S	S	S	S	S	S	S	S		
8'	26	23	28	32	35	37							
10'	25	22	27	31	34	36							
12'	24	21	26	30	33	35							
14'	23	20	25	29	32	34							
16'	22	19	24	28	31	33							
18'	21	18	23	27	30	32							
20'	20	—	22	26	29	31							
22'	—	—	21	25	28	30							
24'	—	—	—	24	27	29							
26	—	—	—	—	26	28							
28'	—	—	—	—	26	27							

① Data based on units fired at full input rate and with an entering air temperature of 80° F.

90° Downward Deflector Hood — Propeller and Blower Models

Figure C

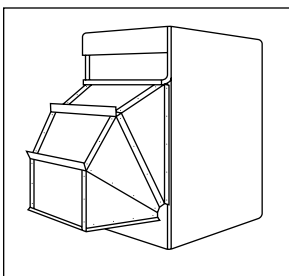

90° Hood

Figure D

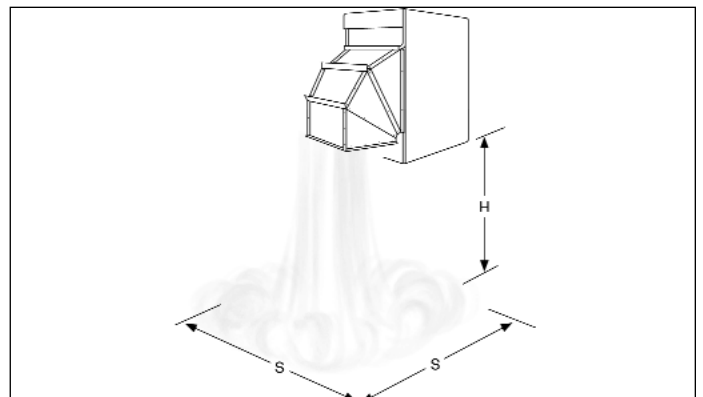

PERFORMANCE DATA

Nozzles - Performance

A choice of four air discharge nozzles accommodate various heat throw patterns illustrated. Equipped with adjustable louver blades, nozzles are fabricated from galvanized steel and are offered either unpainted or painted to match the finish of the blower unit heaters. Nozzles are flanged for easy attachment over the air discharge opening of the blower unit heater.

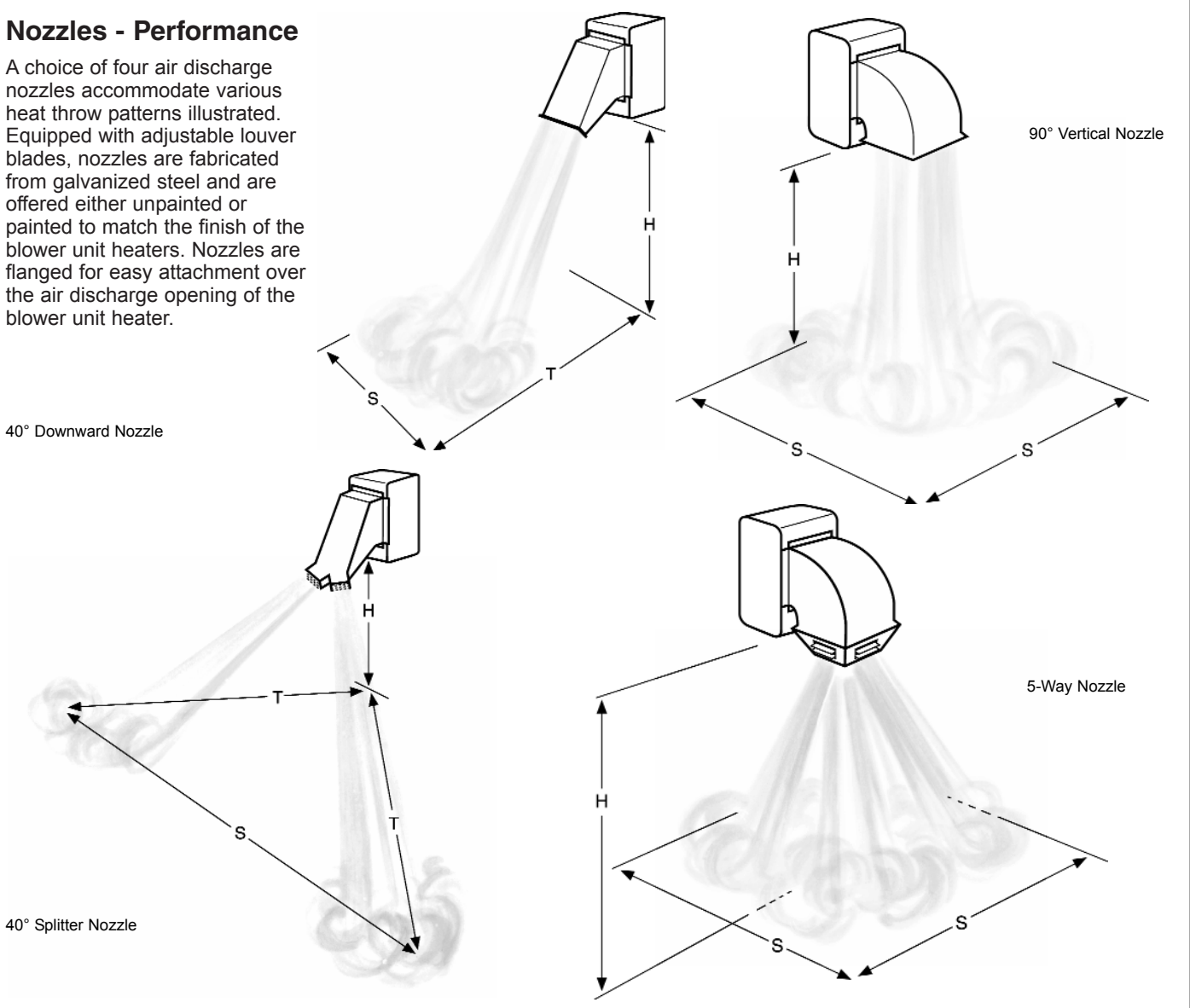

Nozzle Performance Mounting Height, Heat Throw, Heat Spread (in feet)

Nozzle Type		Model Number					
		BSH 130	BSH 150	BSH 170	BSH 225	BSH 280	BSH 340
40° Downward Nozzle	† Max. Mounting Ht. (ft.)	20	21	24	24	26	28
	Heat Throw (ft.)	58	62	71	71	79	83
	Heat Spread (ft.)	20	21	24	24	26	28
90° Vertical Nozzle	† Max. Mounting Ht. (ft.)	20	18	21	24	26	27
	Heat Spread (ft.)	20	18	21	24	26	27
40° Splitter Nozzle	† Max. Mounting Ht. (ft.)	18	18	20	21	25	28
	Heat Throw (ft.)	45	45	51	53	62	69
	Heat Spread (ft.)	90	90	102	106	123	137
5-Way Nozzle	† Max. Mounting Ht. (ft.)	16	16	18	20	19	23
	Heat Spread (ft.)	22	22	25	27	26	31

The above table is based on an inlet air temperature of 70°F and an air temperature rise of 55°F. Air deflectors on 40° and 90° discharge nozzles set perpendicular to the face of the air discharge opening. On 5-way nozzles, bottom air deflectors set perpendicular to floor, all other deflectors at 30° to floor. Static pressure measured at 0.1 W. C. for 90° nozzle 0.2 W. C. for 40° downward and 5-way nozzle and 0.3 W. C. for 40° splitter nozzle. Outlet velocities are approximately 1850 fpm for the 40° nozzle, 900 fpm for the 90° nozzle and 900 fpm for 5-way nozzle. For motor size, drive and blower rpm refer to pages 10 and 11. Mounting Height measured from bottom of unit.

DIMENSIONAL DATA

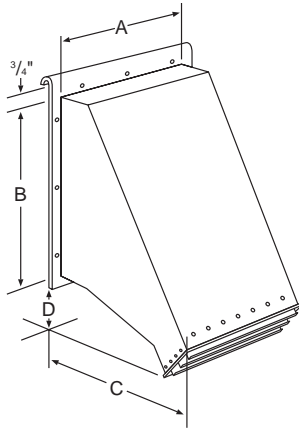

40° Downward Nozzle

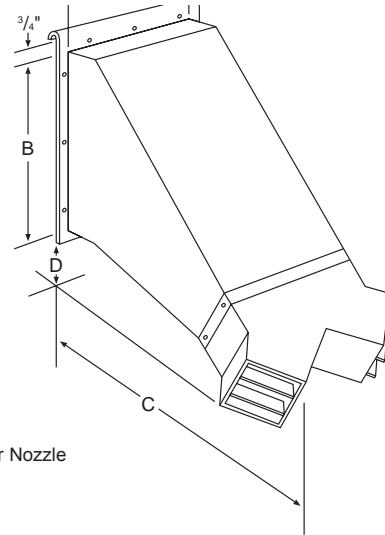

40° Splitter Nozzle

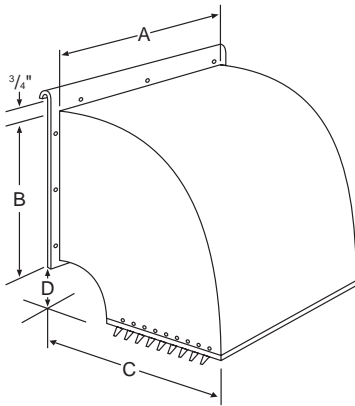

40° Vertical Nozzle

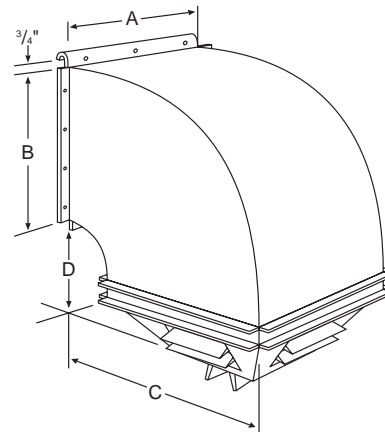

5-Way Nozzle

Dimensions (in feet)

Nozzle Type	Dimension Symbol	Model Number					
		BSH 130	BSH 150	BSH 170	BSH 225	BSH 280	BSH 340
40° Downward Nozzle	A	21-1/16	23-3/16	23-3/16	26-3/16	31-1/8	37-1/2
	B	20	24	24	24	24	24
	C	25	30	30	30	36	36
	D	4	4	4	6	11	11
90° Vertical Nozzle	A	21-1/16	23-3/16	23-3/16	26-3/16	31-1/8	37-1/2
	B	20	24	24	24	24	24
	C	23	29	29	30	34	34
	D	8	10	10	10	14	14
40° Splitter Nozzle	A	21-1/16	23-3/16	23-3/16	26-3/16	31-1/8	37-1/2
	B	20	24	24	24	24	24
	C	33-1/2	39	39	40	46	47
	D	11	12	12	14	19	20-1/2
5-Way Nozzle	A	21	23-3/16	23-3/16	26-3/16	31-1/8	37-1/2
	B	20	24	24	24	24	24
	C	27	29	29	32	37	43-1/2
	D	14	15	15	16	18	18

SERVICE INSTRUCTIONS — SAFETY DEVICES

Figure 13
Rear View Propeller Type Unit

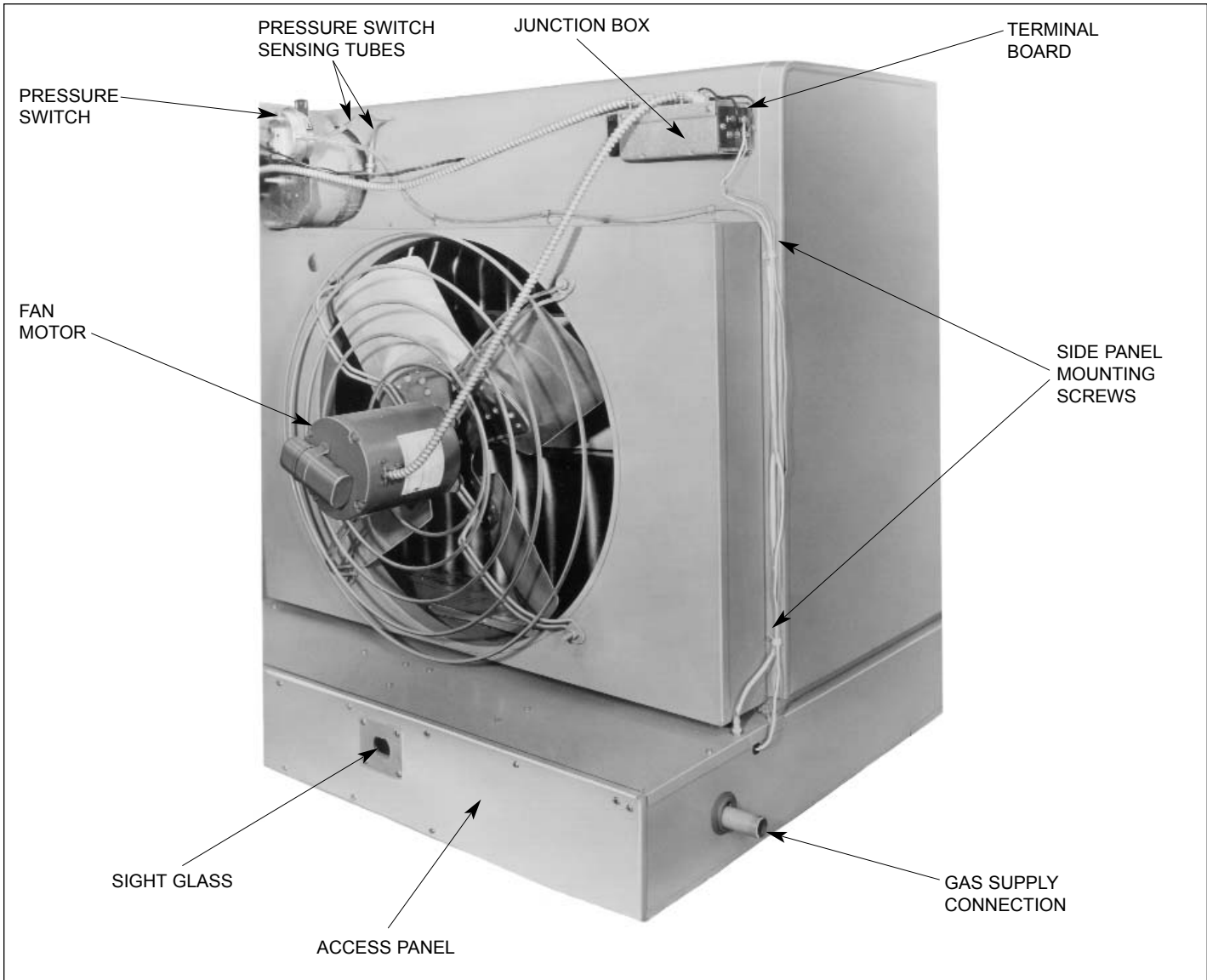

Limit Control (Overheat Switch)

The limit control, mounted on the left inner side panel (when facing front of unit), will shut off the gas supply to the main burner in the event of overheating. It is a single pole single throw switch. The contacts open to shut the combination gas control off in the event the unit should overheat. This limit control should operate only when something is seriously wrong with the unit. Anytime this control operates, correct the difficulty immediately or serious damage may result. If the limit control cuts off the gas supply during normal operation:

1. See that front louvers are open and that there are not any obstructions in the air inlet or outlet.
2. Check actual input to unit against rated input.
3. Check to be sure fan motor is operating.
4. On propeller unit check that fan is not loose on motor shaft. On blower unit check belt and sheave for tightness or damage.
5. On propeller units check fan speed against speed on motor nameplate. On blower units check blower speed against Performance Tables on pages 14 and 15; check for restrictions in ducts and for dirty filters.
6. Check to make sure the venting system and combustion air piping is not damaged or blocked. Also check to be sure unit is venting normally.
7. Clean heat exchanger tubes inside and out if necessary.
8. If items 1-7 do not solve the problem, check limit control and replace if necessary. The control is accessible by removing the left outer side panel, held in place by screws at the rear of the unit.

SERVICE INSTRUCTIONS — GENERAL

Only people trained and familiar with the operation of unit heaters and their controls should service this unit.

General Maintenance

1. Service air moving components annually.
 - a. On propeller units this includes checking motor for lubrication if motor is not there permanently lubricated type and check fan for fit on motor shaft and for damage to blades.
 - b. On blower units this should include:
 - (1) checking motor and blower bearings for lubrication
 - (2) checking belt and sheaves for proper alignment and adjustment
 - (3) checking cleanliness of blower wheel and filters
2. Keep unit free from dust, dirt, grease and foreign matter, paying particular attention to:
 - a. Combustion air inlet terminal.
 - b. Main burner ports, pilot burner, and main burner orifices (avoid use of hard, sharp instruments capable of damaging surfaces, for cleaning these ports). If air pressure is available, use air hose to blow dirt and other foreign matter from within the burner. Also main burner orifices should be checked for blockage due to spider webs, etc.

- c. Primary air shutters (when used).
- d. Clean heat exchanger tubes from bottom with stiff brush after removing burner. (Do not use wire brush.)
- e. Fan blades.

To Remove Main Burner

1. Turn off electricity and gas to unit.
2. Remove access panel (see Figure 13).
3. Remove all fastening screws holding hinged bottom pan in place and lower bottom pan (see Figure 2).
4. Disconnect pilot tubing and ignition cable from the combination gas control and ignition control.
5. Remove the two burner retaining pins holding the burner in place. The burner can then be easily lowered from the unit. In replacing the burner, be certain that the slots at the front of the burner are located properly on their shoulder rivets and that the burner retaining pins are put back into their proper locations.

Replace bottom pan and access panel, making sure a good tight seal is achieved along the entire perimeter of both panels.

TROUBLESHOOTING GUIDE

Figure 14
Manifold Adjustment

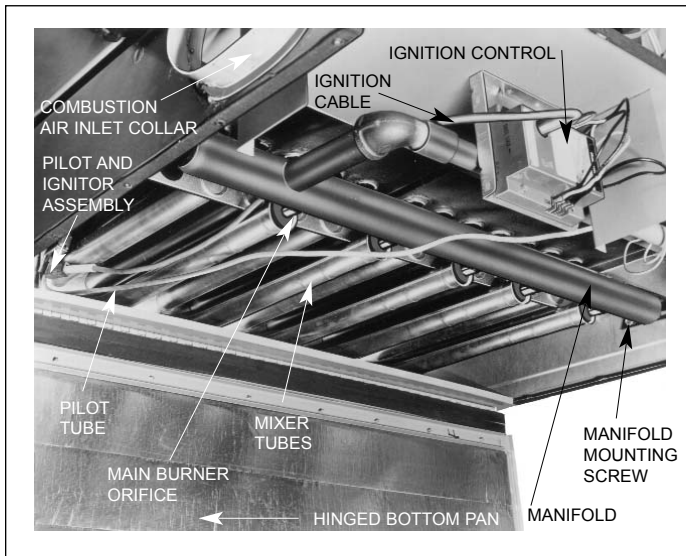

Combustion Diagnosis

To realize full gas heating value requires periodic inspections with proper combustion control corrections as outlined and illustrated here.

1. **Lifting Flames.** Lifting flames rise unevenly above the burner port and may occur on few or all the ports. Sometimes the flames drop and lift intermittently. Lifting can be eliminated by reducing primary air. If flame cannot be adjusted properly, check input rate to heater and manifold gas pressure; reduce if necessary. Check the main burner orifice size with those listed in Table 5 to be sure the unit is not operating over rated input.

Figure 15
Air Shutter Adjustment, Propane Gas

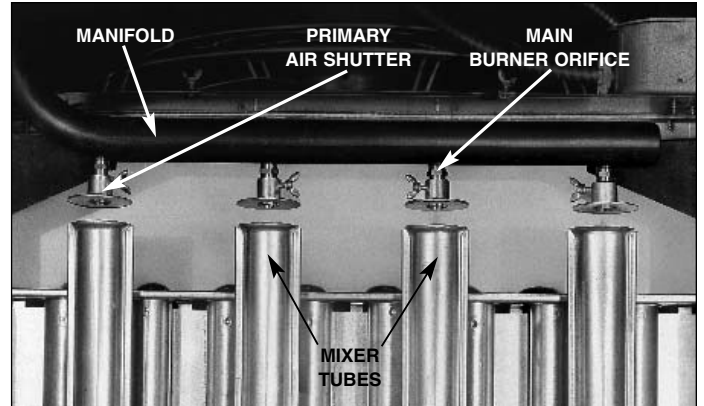
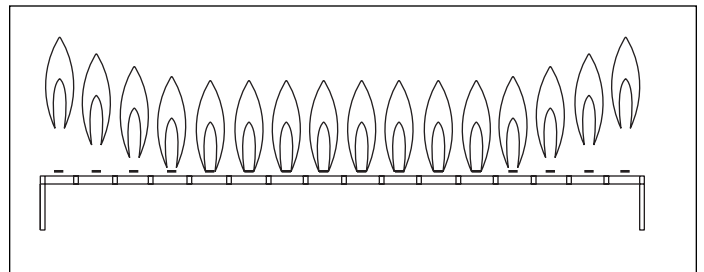

Figure 16
Lifting Flame Condition



TROUBLESHOOTING GUIDE

2. **Yellow Tipping.** Yellow tipping of a normally blue flame is caused by insufficient primary air, and indicates incomplete combustion producing carbon monoxide ethylene, aldehyde, and free carbon (soot). A dirty orifice or one that is out of line, can also reduce primary air and cause yellow tipping. Check main burner orifices, clean, realign, or replace if necessary. With propane gas, some yellow tipping is always present, but is not objectionable.
3. **Flashback.** Flashback occurs when air-gas mixture ignites inside the mixer tube to burn near the orifice. Flashback on ignition or during burner operation usually can be eliminated by reducing primary air. The burner may also be operating below its rated capacity. Check input rate and adjust to correct value by increasing orifice size or manifold gas pressure.

Figure 17
Wavering Flame or Misalignment

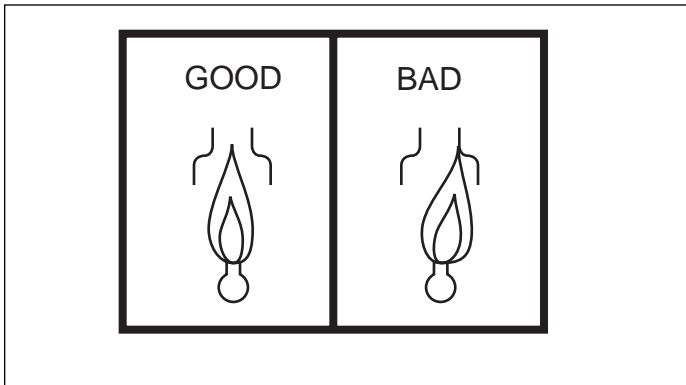

4. **Wavering Flames.** Drafts across burners may cause flames to appear unstable. Wavering flames can lead to incomplete combustion if flames impinge on cool surfaces. Wavering can be caused by air drafts into the burner compartment or by misalignment of the burner. Draft-blown flames may indicate a cracked heat exchanger.

Figure 18
Floating Flame Condition

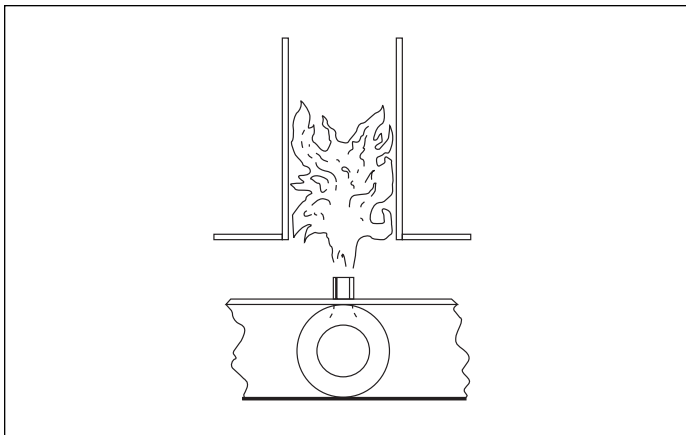

5. **Floating Flames.** Floating flames are long — do not have well-defined cones, roll around in the combustion chamber, sometimes completely off the main burner ports. Usually an aldehyde odor is present to indicate incomplete combustion. If combustion air supply is reduced too far, burner flames will float. Often the pilot flame goes out. Lack of combustion air causes burner flames to float. The unit may be overfired so its flue outlet area may be too small for the increased firing rate. Check input rate and reduce if necessary. Soot

or dust may be blocking the heat exchanger. Check and clear any blockage. Adjust primary air to get rid of yellow tipping that may produce soot to block heat exchanger. Make sure combustion air piping is not blocked.

Intermittent Pilot Ignition Systems

⚠ CAUTION

Do not attempt to reuse an ignition control which has been replaced. Replace defective control.

1. Pilot will not light or stay lit.

Possible Cause	Possible Remedy
1a. No spark at ignitor.	1a. Check connections. Check for proper spark gap, cracked or broken electrode ceramic, blown controller fuse or brittle, cracked or loose high tension cable. Check power exhaust pressure switch. Replace if defective.
1b. Defective flame sensor or loose connections to flame sensor.	1b. Check milli-amps of sensor. Tighten loose connections. Replace flame sensor if necessary.
1c. Pilot valve electrical connections loose.	1c. Tighten connections.
1d. Defective pilot valve.	1d. Replace.
1e. Poor ground connections.	1e. Check grounding means.
1f. No power from control transformer.	1f. Check transformer voltage on secondary side for 25v.
1g. Spark not located in pilot gas stream.	1g. Correct or replace pilot.
1h. Dirty or plugged pilot orifice.	1h. Clean or replace.
1i. Pilot line kinked or obstructed.	1i. Correct or replace pilot line.
1j. Pilot flame too low.	1j. Check pilot flame and adjust per manufacturer's recommendations.
1k. Flame sensor out of position.	1k. Reposition.
1l. Defective ignition controller.	1l. Replace.

TROUBLESHOOTING GUIDE

2. Pilot lights, main burner will not light.

Possible Cause	Possible Remedy
2a. Gas valve in off off position.	2a. Turn to on position.
2b. System in lock-out mode.	2b. Reset system.
2c. Cracked or broken sensor ceramic.	2c. Replace sensor.
2d. Defective or loose connections to flame sensor or flame sensor lead.	2d. Correct or replace.
2e. Incorrect gas pressure.	2e. Check and adjust if necessary to manufacturer's recommendations and replace if necessary.
2f. Insufficient current signal from flame sensor.	2f. Check current according to manufacturer's recommendations and replace if necessary.
2g. Incorrect or loose wiring.	2g. Check wiring.
2h. Poor ground to ignition control.	2h. Check grounding means.
2i. No power to ignition controller or gas valve.	2i. Check voltage to controller and gas valve.
2j. Loose limit control connections or defective unit.	2j. Check connections. Replace limit control if necessary.
2k. Defective or plugged gas valve regulator.	2k. Inspect gas valve regulator. Replace if necessary.
2l. Defective thermostat or thermostat out of calibration.	2l. Calibrate thermostat or replace if necessary.
2m. Thermostat heat anticipator incorrectly set.	2m. Check anticipator setting and correct if necessary.
2n. Defective ignition controller.	2n. Replace.

3. Burner shuts down before thermostat is satisfied.

Possible Cause	Possible Remedy
3a. Flame sensing circuit failure.	3a. Check flame sensing rod, sensor ceramic, sensor lead and connections for damage or loss of continuity. Replace defective elements.
3b. Soot on sensing rod.	3b. Clean off soot and adjust pilot to smaller size.
3c. Blockage in heat exchanger.	3c. Clean heat exchanger. Determine cause and correct.
3d. Blockage in main burner orifice.	3d. Clean or replace orifice.

4. Burner fails to shut off after thermostat is satisfied.

Possible Cause	Possible Remedy
4a. Faulty thermostat or improper heat anticipator setting.	4a. Check thermostat and anticipator setting. Replace if defective.
4b. Defective ignition controller.	4b. Replace.
4c. Defective gas control.	4c. Replace.

For Service . . .

If a qualified service person cannot solve the problem, consult your local gas company or local Modine representative.

When servicing, repairing or replacing parts on these units always give the complete Model Number (which includes power code/control code) and Serial Number from the unit rating plate.

RATING PLATE IDENTIFICATION

When servicing, repairing or replacing parts on these units always give the complete Model Number, Power Code Number, Control Code Number and Serial Number from the unit rating plate. The sample below shows what these numbers mean.

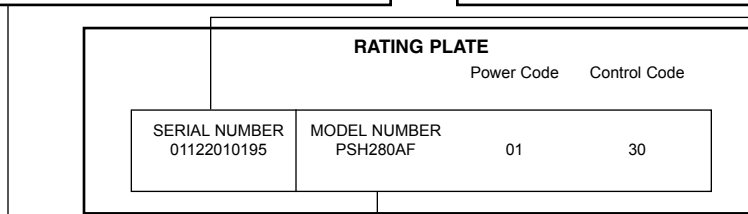
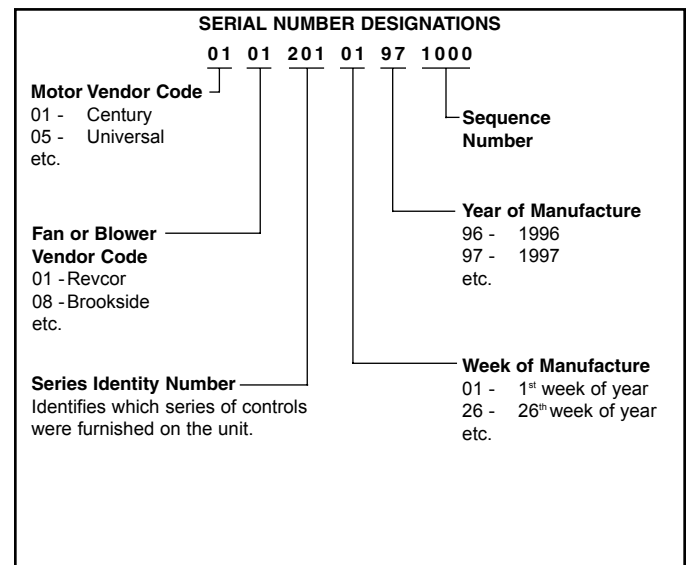
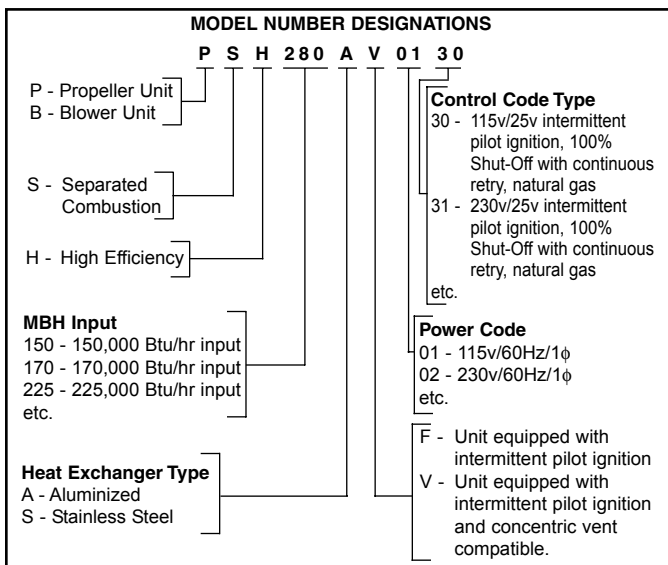

WARRANTY

Seller warrants its products to be free from defects in material and workmanship, EXCLUSIVE, HOWEVER, of failures attributable to the use of materials substituted under emergency conditions for materials normally employed. This warranty covers replacement of any parts furnished from the factory of Seller, but does not cover labor of any kind and materials not furnished by Seller, or any charges for any such labor or materials, whether such labor, materials or charges thereon are due to replacement of parts, adjustments, repairs, or any other work done. This warranty does not apply to any equipment which shall have been repaired or altered outside the factory of Seller in any way so as, in the judgment of Seller, to affect its stability, nor which has been subjected to misuse, negligence, or operating conditions in excess of those for which such equipment was designed. This warranty does not cover the effects of physical or chemical properties of water or steam or other liquids or gases used in the equipment.

BUYER AGREES THAT SELLER'S WARRANTY OF ITS PRODUCTS TO BE FREE FROM DEFECT IN MATERIAL AND WORKMANSHIP, AS LIMITED HEREIN, SHALL BE IN LIEU OF AND EXCLUSIVE OF ALL OTHER WARRANTIES, EITHER EXPRESS OR IMPLIED, WHETHER ARISING FROM LAW, COURSE OF DEALING, USAGE OF TRADE, OR OTHERWISE, **THERE ARE NO OTHER WARRANTIES, INCLUDING WARRANTY OF MERCHANTABILITY OR FITNESS FOR PURPOSE, WHICH EXTEND BEYOND THE PRODUCT DESCRIPTION CONFIRMED BY BUYER AND SELLER AS OF THE DATE OF FINAL AGREEMENT.**

This warranty is void if the input to the product exceeds the rated input as indicated on the product serial plate by more than 5% on gas-fired and oil-fired units, or if the product in the judgment of SELLER has been installed in a corrosive atmosphere, or subjected to corrosive fluids or gases, been subjected to misuse, negligence, accident, excessive thermal shock, excessive humidity, physical damage, impact, abrasion, unauthorized alterations, or operation contrary to SELLER'S printed instructions, or if the serial number has been altered, defaced or removed.

Heat Exchangers

For Seller's non-separated combustion Gas-Fired Unit Heaters BUYER'S REMEDY FOR BREACH OF WARRANTY, EXCLUSIVE OF ALL OTHER REMEDIES PROVIDED BY LAW, IS LIMITED TO REPAIR OR REPLACEMENT AT THE FACTORY OF SELLER, ANY HEAT EXCHANGER WHICH SHALL, WITHIN TEN YEARS FROM DATE OF FIRST BENEFICIAL USE BY BUYER OR ANY OTHER USER, WITHIN TEN YEARS FROM DATE OF RESALE BY BUYER OR ANY OTHER USER, WITHIN TEN YEARS FROM DATE OF RESALE BY BUYER IN ANY UNCHANGED CONDITION, OR WITHIN ONE HUNDRED TWENTY-SIX MONTHS FROM DATE OF SHIPMENT FROM SELLER, WHICHEVER OCCURS FIRST, BE RETURNED TO SELLER WITH TRANSPORTATION CHARGES PREPAID AND WHICH THE EXAMINATION OF SELLER SHALL DISCLOSE TO HAVE BEEN DEFECTIVE; EXCEPT THAT WHEN THE PRODUCT IS TO BE USED BY BUYER AS A COMPONENT PART OF EQUIPMENT MANUFACTURED BY BUYER, BUYER'S REMEDY FOR BREACH, AS LIMITED HEREIN, SHALL BE LIMITED TO ONE YEAR FROM DATE OF SHIPMENT FROM SELLER. FOR GAS-FIRED PRODUCTS INSTALLED IN HIGH HUMIDITY APPLICATIONS AND UTILIZING STAINLESS STEEL HEAT EXCHANGERS, BUYER'S REMEDY FOR BREACH, AS LIMITED HEREIN, SHALL BE LIMITED TO TEN YEARS FROM DATE OF SHIPMENT FROM SELLER.

For Seller's Low Intensity Gas-Fired Infrared Heaters BUYER'S REMEDY FOR BREACH OF WARRANTY, EXCLUSIVE OF ALL OTHER REMEDIES PROVIDED BY LAW, IS LIMITED TO REPAIR OR REPLACEMENT AT THE FACTORY OF SELLER, ANY HEAT EXCHANGER WHICH SHALL, WITHIN FIVE YEARS FROM DATE OF FIRST BENEFICIAL USE BY BUYER OR ANY OTHER USER, WITHIN FIVE YEARS FROM DATE OF RESALE BY BUYER OR ANY OTHER USER, WITHIN FIVE YEARS FROM DATE OF RESALE BY BUYER IN ANY UNCHANGED CONDITION, OR WITHIN 66 MONTHS FROM DATE OF SHIPMENT FROM SELLER, WHICHEVER OCCURS FIRST, BE RETURNED TO SELLER WITH TRANSPORTATION CHARGES PREPAID AND WHICH THE EXAMINATION OF SELLER SHALL DISCLOSE TO HAVE BEEN DEFECTIVE; EXCEPT THAT WHEN THE PRODUCT IS TO BE USED BY BUYER AS A COMPONENT PART OF EQUIPMENT MANUFACTURED BY BUYER, BUYER'S REMEDY FOR BREACH, AS LIMITED HEREIN, SHALL BE LIMITED TO ONE YEAR FROM DATE OF SHIPMENT FROM SELLER.

Heat Exchanger (Condensers) for all Seller's products except non-separated combustion Gas-Fired Unit Heaters and Infrared Heaters, all Burners except Infrared Heaters, and Sheet Metal for all Seller's products BUYER'S REMEDY FOR BREACH OF WARRANTY, EXCLUSIVE OF ALL OTHER REMEDIES PROVIDED BY LAW, IS LIMITED TO REPAIR OR REPLACEMENT AT THE FACTORY OF SELLER, ANY HEAT EXCHANGER (CONDENSER) OR BURNER WHICH SHALL, WITHIN ONE YEAR FROM DATE OF FIRST BENEFICIAL USE BY BUYER OR ANY OTHER USER, WITHIN ONE YEAR FROM DATE OF RESALE BY BUYER IN ANY

UNCHANGED CONDITION, OR WITHIN EIGHTEEN MONTHS FROM DATE OF SHIPMENT FROM SELLER, WHICHEVER OCCURS FIRST, BE RETURNED TO SELLER WITH TRANSPORTATION CHARGES PREPAID AND WHICH THE EXAMINATION OF SELLER SHALL DISCLOSE TO HAVE BEEN DEFECTIVE; EXCEPT THAT WHEN THE PRODUCT IS TO BE USED BY BUYER AS A COMPONENT PART OF EQUIPMENT MANUFACTURED BY BUYER, BUYER'S REMEDY FOR BREACH, AS LIMITED HEREIN, SHALL BE LIMITED TO ONE YEAR FROM DATE OF SHIPMENT FROM SELLER.

Burners

For Seller's Low Intensity Gas-Fired Infrared Heaters BUYER'S REMEDY FOR BREACH OF WARRANTY, EXCLUSIVE OF ALL OTHER REMEDIES PROVIDED BY LAW, IS LIMITED TO REPAIR OR REPLACEMENT AT THE FACTORY OF SELLER, ANY BURNER WHICH SHALL, WITHIN TWO YEARS FROM DATE OF FIRST BENEFICIAL USE BY BUYER OR ANY OTHER USER, WITHIN TWO YEARS FROM DATE OF RESALE BY BUYER IN ANY UNCHANGED CONDITION, OR WITHIN 30 MONTHS FROM DATE OF SHIPMENT FROM SELLER, WHICHEVER OCCURS FIRST, BE RETURNED TO SELLER WITH TRANSPORTATION CHARGES PREPAID AND WHICH THE EXAMINATION OF SELLER SHALL DISCLOSE TO HAVE BEEN DEFECTIVE; EXCEPT THAT WHEN THE PRODUCT IS TO BE USED BY BUYER AS A COMPONENT PART OF EQUIPMENT MANUFACTURED BY BUYER, BUYER'S REMEDY FOR BREACH, AS LIMITED HEREIN, SHALL BE LIMITED TO ONE YEAR FROM DATE OF SHIPMENT FROM SELLER.

For Seller's High Intensity Gas-Fired Infrared Heaters BUYER'S REMEDY FOR BREACH OF WARRANTY, EXCLUSIVE OF ALL OTHER REMEDIES PROVIDED BY LAW, IS LIMITED TO REPAIR OR REPLACEMENT AT THE FACTORY OF SELLER, ANY BURNER WHICH SHALL, WITHIN TEN YEARS FROM DATE OF FIRST BENEFICIAL USE BY BUYER OR ANY OTHER USER, WITHIN TEN YEARS FROM DATE OF RESALE BY BUYER IN ANY UNCHANGED CONDITION, OR WITHIN 126 MONTHS FROM DATE OF SHIPMENT FROM SELLER, WHICHEVER OCCURS FIRST, BE RETURNED TO SELLER WITH TRANSPORTATION CHARGES PREPAID AND WHICH THE EXAMINATION OF SELLER SHALL DISCLOSE TO HAVE BEEN DEFECTIVE; EXCEPT THAT WHEN THE PRODUCT IS TO BE USED BY BUYER AS A COMPONENT PART OF EQUIPMENT MANUFACTURED BY BUYER, BUYER'S REMEDY FOR BREACH, AS LIMITED HEREIN, SHALL BE LIMITED TO ONE YEAR FROM DATE OF SHIPMENT FROM SELLER.

All Other Components Excluding Heat Exchanger (Condenser), Burner, and Sheet Metal

For all Seller's products except Direct-Fired Heaters and High Intensity Gas-Fired Infrared Heaters BUYER'S REMEDY FOR BREACH OF WARRANTY, EXCLUSIVE OF ALL OTHER REMEDIES PROVIDED BY LAW, IS LIMITED TO REPAIR OR REPLACEMENT AT THE FACTORY OF SELLER, ANY PART OR PARTS WHICH SHALL, WITHIN TWO YEARS FROM DATE OF FIRST BENEFICIAL USE BY BUYER OR ANY OTHER USER, WITHIN TWO YEARS FROM DATE OF RESALE BY BUYER IN ANY UNCHANGED CONDITION, OR WITHIN THIRTY MONTHS FROM DATE OF SHIPMENT FROM SELLER, WHICHEVER OCCURS FIRST, BE RETURNED TO SELLER WITH TRANSPORTATION CHARGES PREPAID AND WHICH THE EXAMINATION OF SELLER SHALL DISCLOSE TO HAVE BEEN DEFECTIVE; EXCEPT THAT WHEN THE PRODUCT IS TO BE USED BY BUYER AS A COMPONENT PART OF EQUIPMENT MANUFACTURED BY BUYER, BUYER'S REMEDY FOR BREACH, AS LIMITED HEREIN, SHALL BE LIMITED TO ONE YEAR FROM DATE OF SHIPMENT FROM SELLER.

For Seller's Direct-Fired Heaters and High Intensity Gas-Fired Infrared Heaters BUYER'S REMEDY FOR BREACH OF WARRANTY EXCLUSIVE OF ALL OTHER REMEDIES PROVIDED BY LAW IS LIMITED TO REPAIR OR REPLACEMENT AT THE SELLER'S OPTION ANY PART OR PARTS WHICH SHALL WITHIN A PERIOD OF ONE YEAR FROM DATE OF FIRST BENEFICIAL USE BY BUYER OR ANY OTHER USER, WITHIN ONE YEAR FROM DATE OF RESALE BY BUYER IN ANY UNCHANGED CONDITION, OR WITHIN 18 MONTHS FROM DATE OF SHIPMENT FROM SELLER, WHICHEVER OCCURS FIRST, BE RETURNED TO SELLER WITH TRANSPORTATION CHARGES PREPAID AND WHICH THE EXAMINATION OF THE SELLER SHALL DISCLOSE TO HAVE BEEN DEFECTIVE. BUYER AGREES THAT IN NO EVENT WILL SELLER BE LIABLE FOR COSTS OF PROCESSING, LOST PROFITS, INJURY TO GOODWILL, OR ANY OTHER CONSEQUENTIAL OR INCIDENTAL DAMAGES OF ANY KIND RESULTING FROM THE ORDER OR USE OF ITS PRODUCT, WHETHER ARISING FROM BREACH OF WARRANTY, NONCONFORMITY TO ORDERED SPECIFICATIONS, DELAY IN DELIVERY, OR ANY LOSS SUSTAINED BY THE BUYER.

Modine Manufacturing Company has a continuous product improvement program; it reserves the right to change design and specifications without notice.



6-558

Commercial HVAC&R Division

Modine Manufacturing Company
1221 Magnolia Avenue
Buena Vista, VA 24416
Phone: 1.800.828.4328 (HEAT)
FAX: 1.540.261.1903 (Service & Parts)
www.modine.com