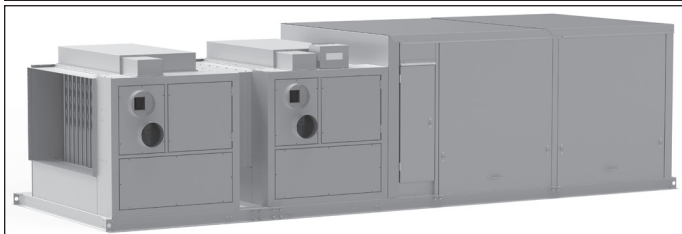
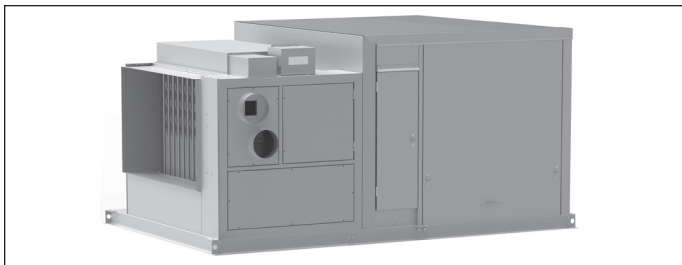

INSTALLATION AND SERVICE MANUAL

indirect gas-fired indoor separated combustion make-up air units

Models DBS/DCS IBS/ICS

**Intertek**

Models approved for use in California by the CEC

⚠️ WARNING

1. Improper installation, adjustment, alteration, service or maintenance can cause property damage, injury or death, and could cause exposure to substances which have been determined by various state agencies to cause cancer, birth defects or other reproductive harm. Read the installation, operating and maintenance instructions thoroughly before installing or servicing this equipment.
2. To prevent premature heat exchanger failure, do not locate ANY gas-fired appliances in areas where corrosive vapors (i.e. chlorinated, halogenated or acid) are present in the atmosphere.

⚠️ AVERTISSEMENT

1. Une installation, un réglage, une altération, une réparation ou une maintenance impropre risque de causer des dommages, des blessures ou la mort, et d'engendrer une exposition à des substances dont certains États ont déterminé qu'elles étaient cancérigènes ou pouvaient causer des malformations à la naissance et des problèmes de reproduction. Lisez bien les instructions d'installation, d'utilisation et de maintenance avant d'installer ou de réparer cet appareil.

⚠️ AVERTISSEMENT

2. Pour éviter la panne prématurée de l'échangeur thermique, ne placez AUCUN appareil à gaz à des endroits où les vapeurs corrosives (chlorées, halogénées ou acides) sont présentes dans l'atmosphère.

FOR YOUR SAFETY

IF YOU SMELL GAS:

1. Open windows.
2. Do not try to light any appliance.
3. Don't touch electrical switches.
4. Extinguish any open flame.
5. Immediately call your gas supplier.

POUR VOTRE SÉCURITÉ

Si vous sentez une odeur de gaz:

1. Ouvrez les fenêtres.
2. Ne tentez d'allumer aucun autre appareil.
3. Ne touchez pas aux interrupteurs électriques.
4. Éteignez toute flamme nue.
5. Appelez immédiatement votre compagnie de gaz.

FOR YOUR SAFETY

The use and storage of gasoline or other flammable vapors and liquids in open containers in the vicinity of this appliance is hazardous.

POUR VOTRE SÉCURITÉ

L'utilisation et le stockage d'essence ou d'autres vapeurs et liquides inflammables dans des récipients ouverts à proximité de cet appareil sont dangereux.

IMPORTANT

1. The use of this manual is specifically intended for a qualified installation and service agency. A qualified installation and service agency must perform all installation and service of these appliances.
2. This appliance is not intended for use by persons (including children) with reduced physical, sensory, or mental capabilities, or lack of experience and knowledge, unless they have been given supervision or instruction concerning use of the appliance by a person responsible for their safety.
3. Children should be supervised to ensure that they do not play with the appliance.

IMPORTANT

1. Ce manuel est spécifiquement destiné au personnel d'une entreprise qualifiée d'installation et d'entretien. Toutes les opérations d'installation et d'entretien doivent être confiées à une entreprise qualifiée.
2. Cet appareil n'est pas conçu pour être utilisé ou entretenu par des personnes (y compris des enfants) dont les capacités physiques, sensorielles ou mentales sont réduites, ou qui n'ont pas l'expérience et les connaissances suffisantes, à moins d'être supervisées ou d'avoir obtenu des directives concernant l'utilisation de l'appareil par une personne responsable de leur sécurité.
3. Les enfants doivent être supervisés pour s'assurer qu'ils ne jouent pas avec l'appareil.

INSPECTION ON ARRIVAL

1. Inspect unit upon arrival. In case of damage, report it immediately to transportation company and your local factory sales representative.
2. Check rating plate on unit to verify that power supply meets available electric power at the point of installation.
3. Inspect unit received for conformance with description of product ordered (including specifications where applicable)

TABLE OF CONTENTS

Inspection On Arrival	2
Special Precautions	3
Hazard Intensity Levels	3
SI (Metric) Conversion Factors	5
Unit Location	6
Unit Suspension	7
Floor Mounted Units	8
Unit Lifting	10
Duct Connections / Utility Connections	11
Installation - Venting	12
Section A - General Instructions - All Units	12
Section B - Vertical 2-Pipe Vent System Installation	14
Section C - Horizontal 2-Pipe Vent Installation	15
Section D - Concentric Vent System Installation	15
Installation - Gas Connections	18
Installation - Electrical Connections	21
Installation - Cooling Coil Units	24
Start-Up Procedure	26
Pilot Burner Adjustment	27
Main Burner Adjustment	27
Air Shutter Adjustment	29
Blower Adjustments	29
Lubrication Recommendations	30
Damper Linkage Adjustment	30
Furnace Control Operating Sequence	30
Variable Air Volume Applications	32
Component Locations	33
Component Descriptions	34
General Performance Data	42
Option & Accessory Pressure Drop Data	44
Blower Performance Data	45
Blower Sheave Assembly Data	48
Dimensions - Unit	50
Dimensions - Cooling Coils	53
Weights	54
Maintenance	55
Electrical Wiring	55
Blower Assembly	55
Filters	55
Cooling Coil Maintenance	56
Duct Furnace	56
Gas Piping & Controls	56
Manifold Assembly Removal	56
Burner and Pilot Assembly Removal	57
Service & Troubleshooting	58
Start-Up Checklist	61
Model Designations	62
Model Identification	62
Model Nomenclature For System Units	63

SPECIAL PRECAUTIONS

SPECIAL PRECAUTIONS

THE INSTALLATION AND MAINTENANCE INSTRUCTIONS IN THIS MANUAL MUST BE FOLLOWED TO PROVIDE SAFE, EFFICIENT, AND TROUBLE-FREE OPERATION. IN ADDITION, PARTICULAR CARE MUST BE EXERCISED REGARDING THE SPECIAL PRECAUTIONS LISTED BELOW. FAILURE TO PROPERLY ADDRESS THESE CRITICAL AREAS COULD RESULT IN PROPERTY DAMAGE OR LOSS, PERSONAL INJURY, OR DEATH. THESE INSTRUCTIONS ARE SUBJECT TO ANY MORE RESTRICTIVE LOCAL OR NATIONAL CODES.

HAZARD INTENSITY LEVELS

1. **DANGER:** Indicates an imminently hazardous situation which, if not avoided, WILL result in death or serious injury.
2. **WARNING:** Indicates a potentially hazardous situation which, if not avoided, COULD result in death or serious injury.
3. **CAUTION:** Indicates a potentially hazardous situation which, if not avoided, MAY result in minor or moderate injury.
4. **IMPORTANT:** Indicates a situation which, if not avoided, MAY result in a potential safety concern.

PRÉCAUTIONS PARTICULIÈRES

LES INSTRUCTIONS D'INSTALLATION ET D'ENTRETIEN DE CE MANUEL DOIVENT ÊTRE OBSERVÉES POUR ASSURER UN FONCTIONNEMENT SÉCURITAIRE, EFFICACE ET FIABLE. DE PLUS, LES PRÉCAUTIONS PARTICULIÈRES CI-APRÈS DOIVENT ÊTRE RIGOREUSEMENT RESPECTÉES. SINON, IL Y AURAIT RISQUE DE DÉGÂTS MATÉRIELS OU DE PERTE, DE BLESSURE PERSONNELLE OU DE MORT D'HOMME. CES INSTRUCTIONS SONT SUJETTES À TOUTE DISPOSITION PLUS RESTRICTIVE DES CODES PROVINCIAL OU NATIONAL.

HIÉRARCHIE DES NIVEAUX DE RISQUES

1. **DANGER :** Indique un danger imminent qui, s'il n'est pas évité, entraînera INÉVITABLEMENT des blessures graves, voire mortelles.
2. **AVERTISSEMENT :** Indique un danger potentiel qui, s'il n'est pas évité, RISQUE d'entraîner des blessures graves, voire mortelles.
3. **ATTENTION :** Indique un danger potentiel qui, s'il n'est pas évité, PEUT entraîner des blessures mineures ou modérées.
4. **IMPORTANT :** Indique une situation qui, si elle se matérialise, PEUT entraîner des risques pour la sécurité des personnes.

DANGER

Appliances must not be installed where they may be exposed to potentially explosive or flammable atmosphere.

DANGER

Les appareils ne doivent pas être installés à un endroit où ils risquent d'être exposés à une atmosphère potentiellement explosive ou inflammable.

WARNING

1. To prevent premature heat exchanger failure, do not locate ANY gas-fired appliances in areas where corrosive vapors (i.e. chlorinated, halogenated or acid) are present in the atmosphere.
2. Ensure that the supply voltage to the appliance, as indicated on the serial plate, is not 5% greater than the rated voltage.
3. When servicing or repairing this equipment, use only Modine-approved service replacement parts. A complete replacement parts list may be obtained by contacting Modine Manufacturing Company. Refer to the rating plate on the appliance for complete appliance model number, serial number, and company address. Any substitution of parts or controls not approved by Modine will be at the owners risk.

AVERTISSEMENT

1. Pour éviter la panne prématurée de l'échangeur thermique, ne placez AUCUN appareil à gaz à des endroits où les vapeurs corrosives (chlorées, halogénées ou acides) sont présentes dans l'atmosphère.
2. Assurez-vous que la tension d'alimentation de l'appareil, comme indiqué sur la plaque de série, n'est pas de 5 % supérieure à la tension nominale.
3. Pour l'entretien et les réparations de cet appareil, utilisez uniquement des pièces d'origine certifiées. Pour la liste complète des pièces de rechange, consultez Modine Manufacturing Company. Le numéro de modèle complet, le numéro de série et l'adresse du fabricant figurent sur la plaque signalétique fixée à l'appareil. Toute substitution de pièce ou de commande non approuvée par le fabricant sera aux risques du propriétaire.

SPECIAL PRECAUTIONS

WARNING

1. Failure to follow proper lifting instructions and applicable safety procedures could result in property damage, serious injury, or death. Lifting should only be done by a qualified rigging company. Use ALL lifting points. Test lift to ensure proper balance and rigging.
2. Gas fired heating equipment must be vented - do not operate unvented.
3. Units have a built-in power exhauster-additional external power exhausters are not required or permitted.
4. All field gas piping must be pressure/leak tested prior to operation. Never use an open flame. Use a soap solution or equivalent for testing.
5. If you are replacing an existing heater, it may be necessary to resize the venting systems. Improperly sized venting systems can result in vent gas leakage or the formation of condensate. Refer to the National Fuel Gas Code ANSI Z223.1 or CSA B149.1 latest edition. Failure to follow these instructions can result in serious injury or death.
6. Under no circumstances should two sections of double wall vent pipe be joined together within one horizontal vent system due to the inability to verify complete seal of inner pipes.
7. The concentric vent adapter box must be installed inside of the structure or building. Do not install this box on the exterior of a building or structure.
8. Gas pressure to appliance controls must never exceed 3.4kPa (14"W.C. or 1/2 psi)
9. To reduce the opportunity for condensation, the minimum sea level input to the appliance, as indicated on the serial plate, must not be less than 5% below the rated input, or 5% below the minimum rated input of dual rated units.
10. Disconnect power supply before making wiring connections or working on this equipment. Follow all applicable safety procedures to prevent accidental power up. Failure to do so can result in injury or death from electrical shock or moving parts and may cause equipment damage.
11. All appliances must be wired strictly in accordance with wiring diagram furnished with the appliance. Any wiring different from the wiring diagram could result in a hazard to persons and property.
12. Any original factory wiring that requires replacement must be replaced with wiring material having a temperature rating of at least 105°C.

AVERTISSEMENT

1. Le non-respect d'une bonne procédure de levage et des procédures de sécurité qui s'appliquent pourrait mener à des dommages matériels ou à des blessures graves, voire mortelles. Le levage doit être effectué uniquement par une entreprise spécialisée dans le gréage. Utilisez TOUS les points de levage. Testez le levage pour assurer un bon équilibre et un bon gréage.
2. Les équipements de chauffage au gaz doivent avoir un système de ventilation – ne les faites pas fonctionner sans évacuation des gaz.
3. Les unités sont munies d'un extracteur électrique intégré – des extracteurs électriques externes supplémentaires ne sont pas requis ni permis.
4. Toutes les canalisations de gaz sur site doivent être testées (pression/fuites) avant usage. Ne recherchez jamais les fuites avec une flamme nue. Utilisez plutôt de l'eau savonneuse ou un produit équivalent.
5. Si vous remplacez un appareil de chauffage existant, vous aurez peut-être à modifier les systèmes de ventilation. Des systèmes de ventilation de diamètre insuffisant peuvent causer des fuites de gaz ou la formation de condensat. Reportez-vous au code National Fuel Gas ANSI Z223.1 ou à la dernière édition de la norme CSA B149.1. Le non-respect de ces directives pourrait entraîner des blessures graves, voire mortelles.
6. Il est interdit d'accoupler deux longueurs de tuyau à double paroi dans une même installation d'évacuation horizontale étant donné l'impossibilité de vérifier l'étanchéité des raccords du tuyau intérieur.
7. La boîte adaptatrice concentrique doit être installée à l'intérieur de la structure ou du bâtiment. Elle n'est pas conçue pour être installée à l'extérieur d'un bâtiment ou d'une structure.
8. La pression de gaz aux commandes de l'appareil ne doit jamais dépasser 3.4 kPa (35,5 cm C.E. ou 1/2 psi).
9. Débranchez l'alimentation électrique avant d'effectuer des connexions ou de travailler sur l'appareil. Respectez toutes les procédures de sécurité qui s'appliquent pour éviter toute mise en marche accidentelle. Le non-respect de cette directive peut entraîner des blessures ou la mort causées par un choc électrique ou des pièces mobiles, en plus d'endommager l'appareil.
10. Tous les appareils doivent être branchés de manière strictement conforme au diagramme fourni. Tout câblage différent de celui du schéma peut créer des risques de dommages matériels ou de blessures
11. Tout câblage usine d'origine exigeant un remplacement doit être remplacé par un câble d'indice thermique nominal de 105 °C.
12. Pour réduire le risque de condensation, l'entrée minimum dans l'appareil au niveau de la mer, telle qu'indiquée sur la plaque de série, ne doit pas être moins de 5 % inférieure à la valeur d'entrée nominale des appareils à double valeur nominale.

SPECIAL PRECAUTIONS / SI (METRIC) CONVERSION FACTORS

⚠ CAUTION

1. Installation must conform with local building codes or in the absence of local codes, with Part 7, Venting of Equipment, of the National Fuel Gas Code, ANSI Z223.1 (NFPA 54)-latest edition. In Canada installation must be in accordance with CSA B149.1.
2. Purging of air from gas lines should be performed as described in ANSI Z223.1 - latest edition "National Fuel Gas Code", or in Canada in CAN/CGA-B149 codes.
3. Ensure that the supply voltage to the appliance, as indicated on the serial plate, is not less than the rated voltage.
4. Do not reuse any mechanical or electrical component which has been wet. Such components must be replaced.

⚠ ATTENTION

1. L'installation doit se faire conformément aux codes locaux de la construction ou, à défaut de tels codes, conformément à la Partie 7 « Venting of Equipment » du National Fuel Gas Code, ANSI Z223.1 (NFPA 54) – dernière édition. Au Canada, l'installation doit se faire conformément à la norme CSA B149.1.
2. La purge de l'air des tuyauteries de gaz doit se faire selon la procédure ANSI Z223.1 de la dernière édition du « National Fuel Gas Code » ou des codes CAN/CGA-B149 du Canada.
3. Vérifiez que la tension d'alimentation de l'appareil n'est pas inférieure de plus de 5 % à la tension nominale inscrite sur la plaque de série.
4. Ne tentez pas de réutiliser un composant mécanique ou électrique qui a été mouillé. Ces composants doivent être remplacés.

IMPORTANT

1. For installation only in locations not accessible to the general public.
2. Unit can be operated up to a maximum of 10,000 feet (3048 m).
3. To prevent premature heat exchanger failure, the input to the appliance, as indicated on the serial plate, must not exceed the rated input by more than 5%.
4. To prevent premature heat exchanger failure, observe heat exchanger tubes by looking at the heat exchanger through the field installed access openings in connecting ductwork in cooling package units or the unit access doors in blower package units. If the bottom of the tubes become red while blower and duct furnace are in operation, check to be sure the blower has been set to the proper rpm for the application. Refer to page 29 for Blower Adjustments.
5. Start up and adjustment procedures, installation, and service of these appliances must be performed by a qualified installation and service agency.
6. To prevent premature heat exchanger failure, with all control systems, a blower starting mechanism must be provided so that the blower is running or energized within 45 seconds of the gas control operation.
7. To check most of the Possible Remedies in the troubleshooting guide listed in Table 58.1 refer to the applicable sections of the manual.

IMPORTANT

1. Pour installation uniquement dans des endroits non accessibles au public.
2. Pour installation uniquement dans des endroits non accessibles au public.
3. Pour éviter une défaillance prématurée de l'échangeur de chaleur, le pouvoir calorifique du gaz utilisé ne doit pas excéder de plus de 5 % la valeur nominale inscrite sur la plaque signalétique de l'appareil.
4. Pour éviter la défaillance prématurée de l'échangeur de chaleur, examinez les tubes de l'échangeur de chaleur en le regardant à travers les ouvertures d'accès installées sur les lieux lors de la connexion des tuyaux ou les portes d'accès à l'unité où il est possible de voir l'échangeur de chaleur. Si le bas des tubes devient rouge lorsque la soufflante et la chaudière canalisée sont en marche, vérifiez que le régime de la soufflante est approprié pour l'application. Pour le réglage de la soufflante, reportez-vous à la page 29.
5. Les procédures de démarrage et de réglage, l'installation et le service de ces appareils doivent être confiés à un centre d'installation et de service qualifié.
6. Pour éviter la panne prématurée de l'échangeur thermique, avec tous les systèmes de commande, un mécanisme de démarrage de la soufflerie doit être fourni pour que la soufflerie démarre dans les 45 secondes qui suivent l'activation de la commande de gaz.
7. Pour essayer la plupart des solutions possibles suggérées dans le guide de dépannage du Table 58.1, reportez-vous aux sections correspondantes du manuel.

Figure 5.1 - SI (Metric) Conversion Factors

To Convert	Multiply By	To Obtain	To Convert	Multiply By	To Obtain
"W.C.	0.24	kPa	CFH	1.699	m ³ /min
psig	6.893	kPa	Btu/ft ³	0.0374	mJ/m ³
°F	(°F-32) x 0.555	°C	pound	0.453	kg
inches	25.4	mm	Btu/hr	0.000293	kW
feet	0.305	meters	gallons	3.785	liters
CFM	0.028	m ³ /min	psig	27.7	"W.C.

SPECIAL DESIGN REQUESTS

Units are sometimes built with special features as requested by the customer. This manual only covers standard features and does not include any changes made for special feature requests by the customer. Units built with special features are noted with a 5-digit SPO (Special Product Order) Number on the Serial Plate.

STORAGE PRIOR TO INSTALLATION

If the unit is stored outside prior to installation, the unit should be covered.

UNIT LOCATION

UNIT LOCATION

DANGER

Appliances must not be installed where they may be exposed to a potentially explosive or flammable atmosphere.

DANGER

Les appareils ne doivent pas être installés à un endroit où ils risquent d'être exposés à une atmosphère potentiellement explosive ou inflammable.

WARNING

To prevent premature heat exchanger failure, do not locate ANY gas-fired appliances in areas where corrosive vapors (i.e. chlorinated, halogenated or acid) are present in the atmosphere.

AVERTISSEMENT

Pour éviter la panne prématurée de l'échangeur thermique, ne placez AUCUN appareil à gaz à des endroits où les vapeurs corrosives (chlorées, halogénées ou acides) sont présentes dans l'atmosphère.

IMPORTANT

1. Installation only in locations not accessible to the general public.
2. Unit can be operated up to a maximum of 10,000 feet (3048 m).

IMPORTANT

1. Pour installation uniquement dans des endroits non accessibles au public.
2. L'unité peut être utilisée jusqu'à un maximum de 3048 m (10,000 ft).

Location Recommendations

1. When locating the furnace, consider general space and heating requirements, availability of gas and electrical supply, and proximity to vent locations.
2. Unit must be installed on the positive pressure side of the circulating blower.
3. Be sure the structural support at the unit location site is adequate to support the weight of the unit. For proper operation the unit must be installed in a level horizontal position.
4. Do not install units in locations where the flue products can be drawn into the adjacent building openings such as windows, fresh air intakes, etc.
5. Be sure that the minimum clearances to combustible materials and recommended service clearances are maintained. Units are designed for installation on non-combustible surfaces with the minimum clearances shown in Figure 7.1 and Table 7.1
6. Units installed downstream of refrigeration systems, or exposed to inlet air temperatures of 40°F or less, may experience condensation, therefore, provisions should be made for disposal of condensate. Means have been provided in the bottom pan of the unit to accommodate a condensate drain line connection flange.
7. When locating units, it is important to consider that the combustion air and exhaust vent piping must be connected to the outside atmosphere. The maximum equivalent lengths are listed in Table 12.1.
8. In garages or other sections of aircraft hangars such as offices and shops which communicate with areas used for servicing or storage, keep the bottom of the unit at least 7" above the floor. In public garages, the unit must be installed in accordance with the Standard for Parking Structures NFPA #88A and the Standard for Repair Garages NFPA#88B. In Canada, installation of unit heaters in airplane hangars must be in accordance with the requirements of the enforcing authority, and in public garages in accordance with the current CAN/CGA-B149 codes.
9. Do not install units in locations where gas ignition system is exposed to water spray, rain, or dripping water.
10. All mechanical equipment generates some sound and vibration that may require attenuation. Libraries, private offices and hospital facilities will require more attenuation, and in such cases, an acoustical consultant may be retained to assist in the application. Locating the equipment away from the critical area is desirable within ducting limitations. Generally, a unit should be located within 15 feet of a primary support beam. Smaller deflections mean lesser vibration and noise transmission.

UNIT LOCATION / UNIT MOUNTING METHODS

Figure 7.1 - Combustible Material Clearances

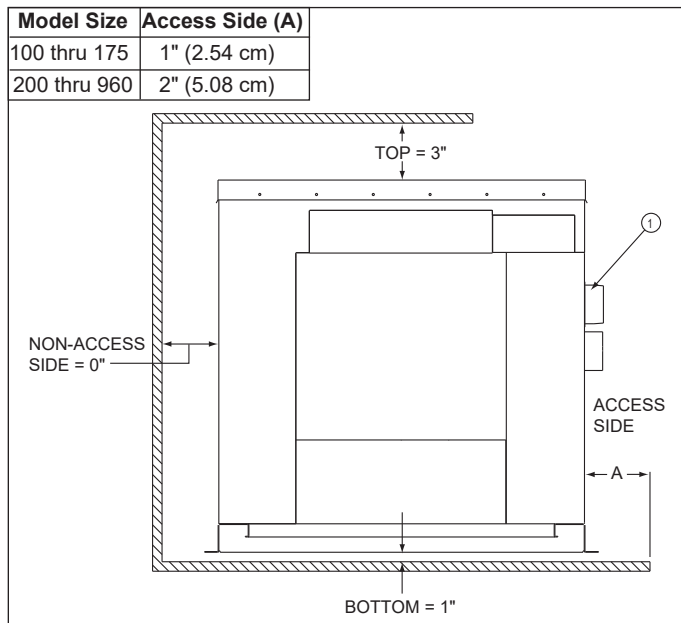

① A 3" minimum clearance to combustible material is required from the vent collar.

Table 7.1 - Recommended Service Clearances

Model Size	Access Side	Non-Access Side	Top
100/125	20.0" (50.80cm)	6" (15.24cm)	10" (25.40cm)
150/175	25.0" (63.50cm)		
200/225	27.0" (68.58cm)		
250/300	30.0" (76.20cm)		
350/400	41.0" (104.14cm)		
500/600	30.0" (76.20cm)		
700/800	41.0" (104.14cm)		
840/960	41.0" (104.14cm)		

Figure 7.2 - Dégagements de matériaux combustibles

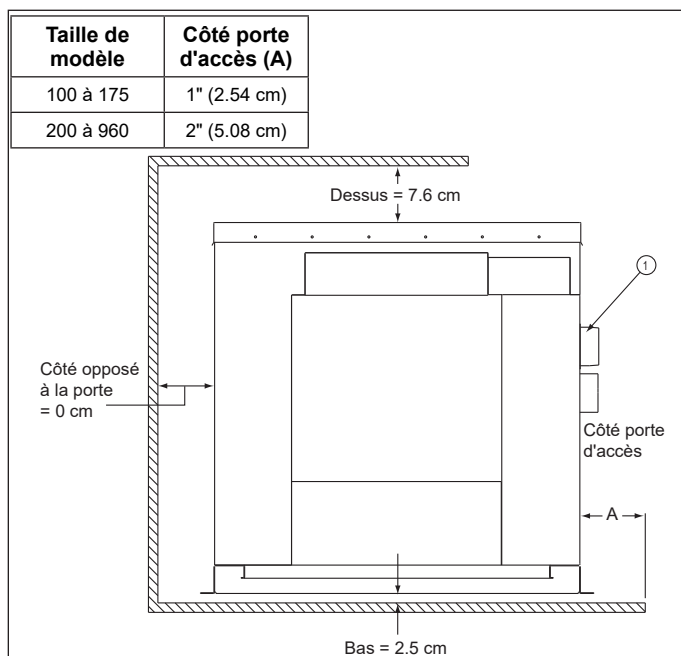

① Un dégagement minimal de 7,6 cm jusqu'au matériau combustible est requis à partir du collet de ventilation..

Tableau 7.2 - Dégagements recommandés pour l'entretien

Taille de modèle	Côté porte d'accès	Côté opposé à la porte	Dessus
100/125	20.0" (50.80cm)	6" (15.24cm)	10" (25.40cm)
150/175	25.0" (63.50cm)		
200/225	27.0" (68.58cm)		
250/300	30.0" (76.20cm)		
350/400	41.0" (104.14cm)		
500/600	30.0" (76.20cm)		
700/800	41.0" (104.14cm)		
840/960	41.0" (104.14cm)		

UNIT MOUNTING METHODS

Determine the method of mounting that will be used. Be sure the method of unit support (suspension or floor mounting) is adequate to support the weight of the unit (see Weights for base unit and factory installed option weights). For proper operation, the unit must be installed in a level horizontal position. Combustible material and service clearances as specified in Figure 7.1 and Table 7.1 must be strictly maintained. To assure that flames are directed into the center of the heat exchanger tubes, the unit must be level in a horizontal position.

Unit Suspension

Four 3/4" (1.90 cm) diameter suspension hanging locations are provided in the base rail assembly of the unit. Refer to Figure 52.1 for Suspension Hanging Locations and Figure 8.1 demonstrates how the unit should be suspended and fastened to the unit base rail. If required, vibration isolators may be added.

Suspension de l'appareil

Quatre emplacements de suspension de 1,9 cm (0.75") de diamètre sont fournis dans l'assemblage du rail de base de l'appareil. Reportez-vous à la Figure 52.1 pour connaître les emplacements de suspension et la Figure 8.1 démontre la façon dont l'appareil doit être suspendu et les tiges de suspension fixées au rail de base de l'appareil. Si nécessaire, des isolateurs de vibration peuvent être ajoutés.

UNIT MOUNTING METHODS

Figure 8.1 - Unit Suspension Method

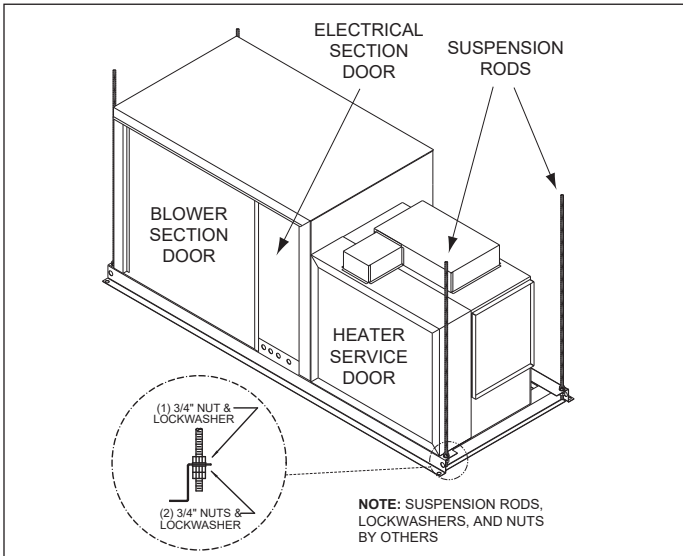

Figure 8.1 - Méthode de suspension de l'appareil

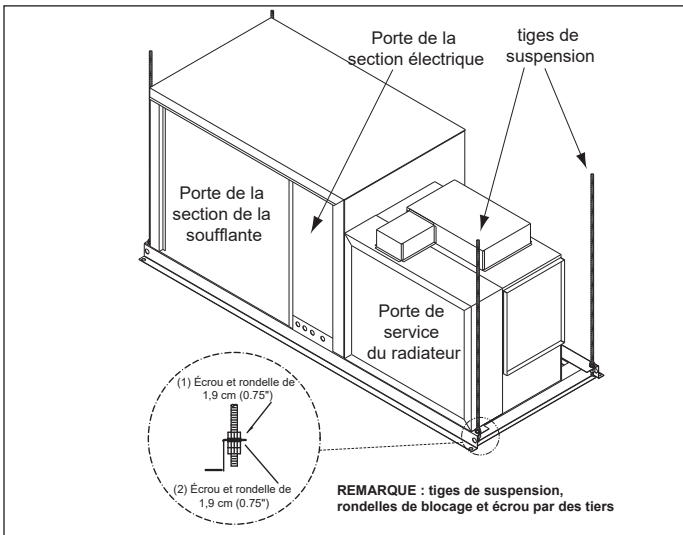

Figure 8.2 - Floor Mounted Unit Anchor Bolt Locations

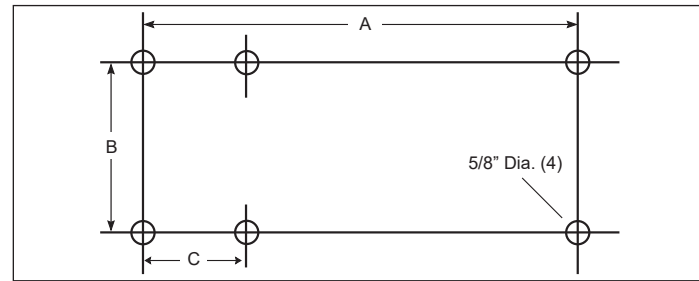
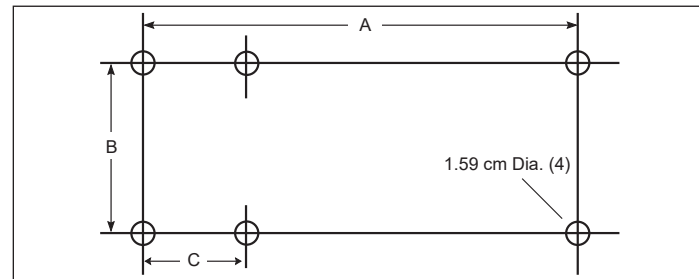

Figure 8.2 - Emplacements des boulons d'ancrage pour appareil installé sur le plancher



Floor Mounted Units

For floor installations, the floor structure must be adequately designed to support the live weight load of the unit and any other required support structure. Additional reinforcement should be provided, if necessary. The floor should include threaded 5/8-inch anchor bolts spaced according to Figure 8.2 and Table 9.1, for securing the unit in place. Anchor bolts should extend at least 1.5" (3.81 cm) above the surface of the floor to allow clearance for mounting washers, nuts and bolts (mounting washers, nuts, and bolts by others).

Modèles installés sur le plancher

Pour les installations sur le plancher, la structure du toit doit être correctement conçue pour soutenir la charge utile de l'appareil et de toute autre structure de soutien requise. Au besoin, tout renforcement supplémentaire devra être fourni. Le plancher doit inclure des boulons d'ancrage filetés de 5/8" (1.59cm) espacés comme dans la Figure 8.2 and Tableau 9.1, pour fixer l'appareil en place. Les boulons d'ancrage doivent se prolonger au-delà de la surface du plancher d'au moins 1,81 cm (1.5 inch) pour permettre un dégagement suffisant pour la mise en place des rondelles, des boulons et des écrous (par des tiers).

UNIT MOUNTING METHODS

Table 9.1 - Floor Mounted Unit Anchor Bolt Locations

Digit 2	Model Size	Blower Type (Digit 16)	A	B	C	
B	100/125	All	86.37" (219.38cm)	36.36 (92.35cm)	-	
	150/175	All	86.37" (219.38cm)	40.61" (103.15cm)	-	
	200/225	All	86.37" (219.38cm)	42.71" (108.48cm)	-	
	250/300	E,F,G, or H	86.27" (219.13cm)	45.75" (116.21cm)	-	
	250/300	I, J, or K	112.12" (284.78cm)	45.75" (116.21cm)	-	
	350/400	E, F, G, or H	86.27" (219.13cm)	57.27" (145.47cm)	-	
	350/400	I, J, or K	122.2" (310.39cm)	57.27" (145.47cm)	-	
	500/600	G or H	127.39" (323.57cm)	45.75" (116.21cm)	41.37" (105.08cm)	
	500/600	I, J, or K	163.25" (414.66cm)	45.75" (116.21cm)	41.37" (105.08cm)	
	700/800	G or H	127.39" (323.57cm)	57.27" (145.47cm)	41.37" (105.08cm)	
	700/800	I, J, K, or L	163.25" (414.66cm)	57.27" (145.47cm)	41.37" (105.08cm)	
	840/960	I, J, K, or L	204.39" (519.15cm)	57.27" (145.47cm)	82.50" (209.55cm)	
	C	100/125	All	110.25" (280.04cm)	36.36" (92.35cm)	-
		150/175	All	110.25" (280.04cm)	40.61" (103.15cm)	-
200/225		All	110.25" (280.04cm)	42.71" (108.48cm)	-	
250/300		E,F,G, or H	110.25" (280.04cm)	45.75" (116.21cm)	-	
250/300		I, J, or K	146.10" (371.09cm)	45.75" (116.21cm)	-	
350/400		E, F, G, or H	110.25" (280.04cm)	57.27" (145.47cm)	-	
350/400		I, J, or K	146.10" (371.09cm)	57.27" (145.47cm)	0	

Tableau 9.1 - Emplacements des boulons d'ancrage pour appareil installé sur le plancher

2 ^e chiffre	Taille de modèle	Type de ventilateur (16 ^e chiffre)	A	B	C	
B	100/125	All	86.37" (219.38cm)	36.36 (92.35cm)	-	
	150/175	All	86.37" (219.38cm)	40.61" (103.15cm)	-	
	200/225	All	86.37" (219.38cm)	42.71" (108.48cm)	-	
	250/300	E,F,G, or H	86.27" (219.13cm)	45.75" (116.21cm)	-	
	250/300	I, J, or K	112.12" (284.78cm)	45.75" (116.21cm)	-	
	350/400	E, F, G, or H	86.27" (219.13cm)	57.27" (145.47cm)	-	
	350/400	I, J, or K	122.2" (310.39cm)	57.27" (145.47cm)	-	
	500/600	G or H	127.39" (323.57cm)	45.75" (116.21cm)	41.37" (105.08cm)	
	500/600	I, J, or K	163.25" (414.66cm)	45.75" (116.21cm)	41.37" (105.08cm)	
	700/800	G or H	127.39" (323.57cm)	57.27" (145.47cm)	41.37" (105.08cm)	
	700/800	I, J, K, or L	163.25" (414.66cm)	57.27" (145.47cm)	41.37" (105.08cm)	
	840/960	I, J, K, or L	204.39" (519.15cm)	57.27" (145.47cm)	82.50" (209.55cm)	
	C	100/125	All	110.25" (280.04cm)	36.36" (92.35cm)	-
		150/175	All	110.25" (280.04cm)	40.61" (103.15cm)	-
200/225		All	110.25" (280.04cm)	42.71" (108.48cm)	-	
250/300		E,F,G, or H	110.25" (280.04cm)	45.75" (116.21cm)	-	
250/300		I, J, or K	146.10" (371.09cm)	45.75" (116.21cm)	-	
350/400		E, F, G, or H	110.25" (280.04cm)	57.27" (145.47cm)	-	
350/400		I, J, or K	146.10" (371.09cm)	57.27" (145.47cm)	0	

UNIT LIFTING

UNIT LIFTING

WARNING

Failure to follow proper lifting instructions and applicable safety procedures could result in property damage, serious injury, or death. Lifting should only be done by a qualified rigging company. Use ALL lifting points. Test lift to ensure proper balance and rigging.

AVERTISSEMENT

Le non-respect d'une bonne procédure de levage et des procédures de sécurité qui s'appliquent pourrait mener à des dommages matériels ou à des blessures graves, voire mortelles. Le levage doit être effectué uniquement par une entreprise spécialisée dans le gréage. Utilisez TOUS les points de levage. Testez le levage pour assurer un bon équilibre et un bon gréage.

Rigging and lifting of the units should only be done by a qualified rigging company and follow appropriate industry standards, including but not limited to the appropriate sections of ASME B30, OSHA 1910, and OSHA 1926.

1. Follow site preparation instructions for overhead suspension, floor mounting, equipment stand before installation.
2. Check the Serial Plate(s) of unit with plans to be sure unit is properly located. Although units may look outwardly similar, their function, capacities, options, and accessories will often vary.
3. Check unit dimensions of both the unit base and the installation location where the unit will be installed.
4. The provisions for lifting are dependent on how the unit was shipped:
 - a. All units with standard blower cabinets (Model Digit 16=A through H) are shipped fully crated with skid supports below the unit. The unit may be lifted from the bottom by means of a fork lift or other lifting device only if the shipping support skids are left in place. DO NOT attempt to lift the unit from the bottom unless the shipping skid supports are still in place. When lifting units, make sure the load is balanced.
 - b. All units with extended blower cabinets (Model Digit 16=I through L) are shipped without a crate and cannot be lifted with a fork truck. Use a crane or other overhead lifting device in conjunction with the lifting holes for safe unit relocation (refer to the Dimensions for base rail lifting hole locations). See the following note #5. If the unit must be lifted from the bottom for final installation, be sure to properly support the unit over its entire length to prevent damage.
5. When lifting the equipment with a crane, connect sturdy steel cables, chains, or straps. For stability in lifting and lowering and to prevent damage to the unit, include a spreader bar. Avoid twisting or uneven lifting of the unit. Test lift the unit to check for proper rigging balance before hoisting to the desired installation location.
6. Position the unit to its ductwork or where ductwork will be located and suspend or floor mount the unit. For proper operation, the unit must be installed in a level horizontal position. Use a spirit level to ensure that the unit is suspended or floor mounted correctly.
7. Refer to the applicable sections to make Venting, Gas Connections, Electrical Connections, and Cooling Coil Connections. Make final unit connections to the electric power supply and remote control circuits. Caulk all utility line clearance holes on the unit after connections are completed.
8. Refer to the applicable sections to make final unit connections for venting, gas and electrical utility connections, control wiring, and cooling system connections if equipped. Caulk all utility line clearance holes on the unit after connections are completed.

DUCT CONNECTIONS / UTILITY CONNECTIONS

DUCT CONNECTIONS

1. The furnace discharge (units with Model Digit 2=B) is designed to accept straight ductwork (see Figure 11.1). The blower section end and bottom openings (all units) and cooling cabinet section discharge (units with Model Digit 2=C) are designed to accept 90° flanged ductwork (see Figure 11.2).
Provide an airtight seal between the ductwork and the furnace. Seams with cracks in the ductwork should be caulked and/or taped and be of permanent type. All duct connections MUST be airtight to prevent air leakage.
2. Provide uniform air distribution over the heat exchanger. Use turning vanes where required to obtain uniform air distribution. (See Figure 11.3).
3. Provide removable access panels on the downstream side of the ductwork. (See Figure 11.1.) This opening should be large enough to view smoke or reflect light inside the casing

Figure 11.1 - Furnace Discharge Duct Connection

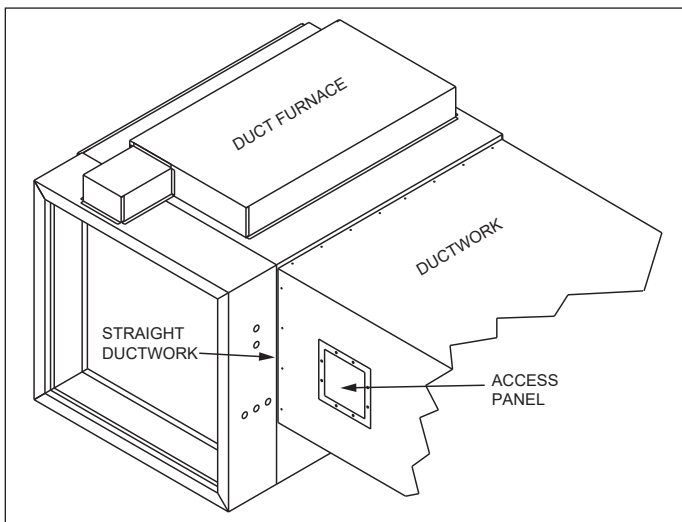

Figure 11.2 - Blower Section Inlet and Cooling Coil Section Discharge Duct Connections

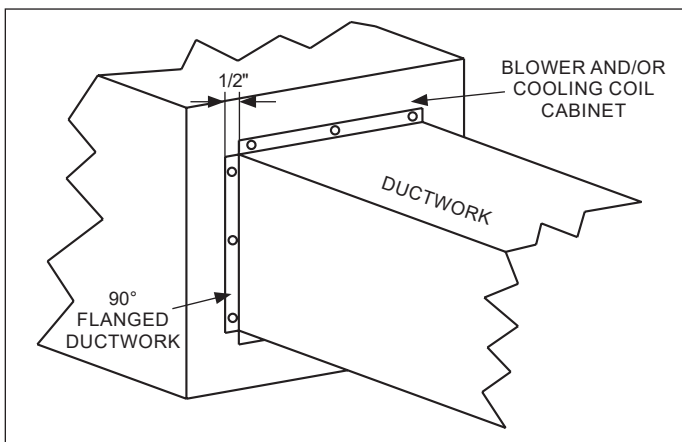
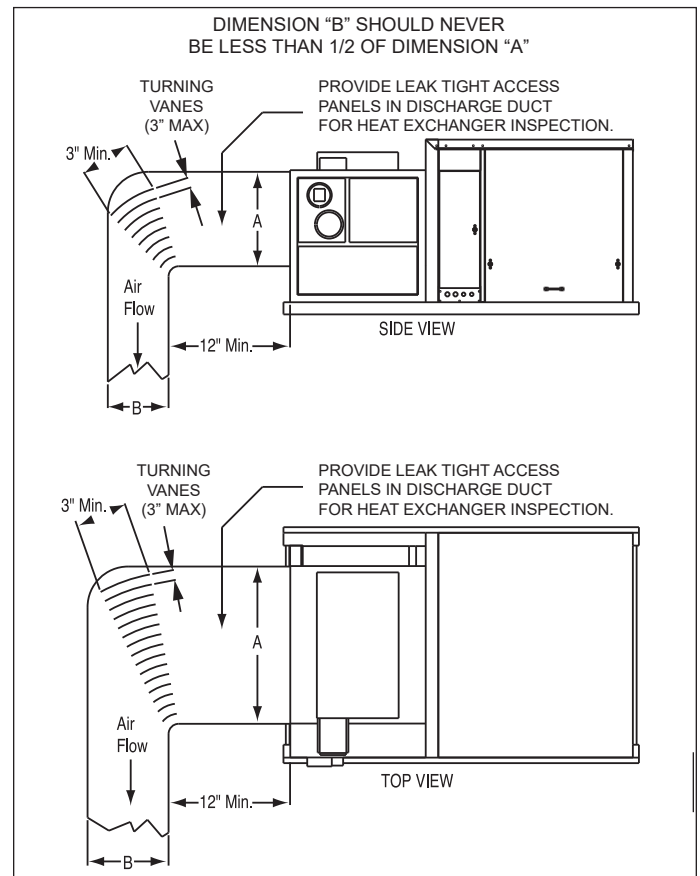

Figure 11.3 - Recommended Field Installed Discharge Duct Configurations for Blower Package Units



UTILITY CONNECTIONS

Utility and control connections can be made to the unit from the bottom or through the fixed side panels for floor mounted units. Holes can be made in fixed side panels to accommodate utility connections for any model or as specified according to the unit dimensional drawings. Sealing of holes cut in the unit casing for utility connections should be done with care to prevent air leaks.

INSTALLATION - VENTING

UNIT INSTALLATION

Refer to the applicable sections to make Venting, Gas Connections, Electrical Connections, and Cooling Coil Connections. Make final unit connections to the electric power supply and remote control circuits. Caulk all utility line clearance holes on the unit after connections are completed.

Venting

WARNING

1. Gas fired heating equipment must be vented - do not operate unvented.
2. A built-in power exhauster is provided - additional external power exhausters are not required or permitted.
3. If you are replacing an existing heater, it may be necessary to resize the venting systems. Improperly sized venting systems can result in vent gas leakage or the formation of condensate. Refer to the National Fuel Gas Code ANSI Z223.1 or CSA B149.1 latest edition. Failure to follow these instructions can result in serious injury or death.
4. Under no circumstances should two sections of double wall vent pipe be joined together within one horizontal vent system due to the inability to verify complete seal of inner pipes.

AVERTISSEMENT

1. Les équipements de chauffage au gaz doivent avoir un système de ventilation – ne les faites pas fonctionner sans évacuation des gaz.
2. Les unités sont munies d'un extracteur électrique intégré – des extracteurs électriques externes supplémentaires ne sont pas requis ni permis.
3. Si vous remplacez un appareil de chauffage existant, vous aurez peut-être à modifier les systèmes de ventilation. Des systèmes de ventilation de diamètre insuffisant peuvent causer des fuites de gaz ou la formation de condensat. Reportez-vous au code National Fuel Gas ANSI Z223.1 ou à la dernière édition de la norme CSA B149.1. Le non-respect de ces directives pourrait entraîner des blessures graves, voire mortelles.
4. Il est interdit d'accoupler deux longueurs de tuyau à double paroi dans une même installation d'évacuation horizontale étant donné l'impossibilité de vérifier l'étanchéité des raccords du tuyau intérieur.

CAUTION

Installation must conform with local building codes or in the absence of local codes, with Part 7, Venting of Equipment, of the National Fuel Gas Code, ANSI Z223.1 (NFPA 54) - latest edition. In Canada installation must be in accordance with CSA B149.1.

ATTENTION

L'installation doit se faire conformément aux codes locaux de la construction ou, à défaut de tels codes, conformément à la Partie 7 « Venting of Equipment » du National Fuel Gas Code, ANSI Z223.1 (NFPA 54) – dernière édition. Au Canada, l'installation doit se faire conformément à la norme CSA B149.1.

The separated combustion duct furnaces must be vented with the proper passageway as described in these instructions to convey flue gases from the unit or the vent connector to the outside atmosphere. The heaters must also have a separate combustion air intake pipe to bring in fresh air for combustion from the outside atmosphere.

The venting instructions are organized in sections, based on installation type. The sections are identified as follows:

Section	Installation Instructions by Vent System Type
A	General Instructions for ALL installations
B	VERTICAL 2-PIPE Vent Systems ①
C	HORIZONTAL 2-PIPE Vent Systems ①
D	HORIZONTAL AND VERTICAL CONCENTRIC Vent Systems ①

① The differences between Vertical and Horizontal vent systems in 2-Pipe or Concentric Vent configurations will be identified in "Section A - General Instructions – All Units".

Section A - General Instructions - All Units

- A1. If the heater being installed is replacing existing equipment and using the existing vent system from that equipment, inspect the venting system for proper size and horizontal pitch, as required in the National Fuel Gas Code ANSI Z223.1 or CSA B149.1 Installation Code-latest edition and these instructions. Determine that there is no blockage or restriction, leakage, corrosion and other deficiencies, which could cause an unsafe condition.
- A2. The combustion air and vent pipes should be galvanized steel or other suitable corrosion resistant material. Follow the National Fuel Gas Code for minimum thickness of vent material. The minimum thickness for connectors varies depending on the pipe diameter. Do not vent unit with PVC or other forms of plastic venting material.
- A3. All heaters come with factory installed vent and combustion air adapters for attaching the pipe to the heater. The pipe diameters are 4" for model sizes 100-175 and 6" for model sizes 200-400. All units are classified as Category III vented appliances, which defined by ANSI is positive pressure, non-condensing, and requires the vent system to be gastight. Attach the vent pipe to the adapter with 3 corrosion resistant screws. (Drill pilot holes through the vent pipe and adapter prior to screwing in place). Vent pipe must not be smaller than the connector size. Category III vent systems listed by a nationally recognized agency and matching the diameters specified may be used. Different brands of vent materials may not be intermixed.
- A4. Limit the total equivalent vent pipe length to a minimum of 5' and a maximum as shown in Table 12.1, making the vent system as straight as possible. Total equivalent vent pipe length must include elbows. The equivalent length of a 4" elbow is 5' and for a 6" elbow is 7'

Table 12.1 - Individual Total Equivalent Lengths for Combustion Air and Exhaust Vent Pipes

Model Size	Minimum (ft)	Maximum (ft)
100, 125, 150, 175	5	55
200, 225	5	70
250, 300	5	63
350, 400	5	70

INSTALLATION - VENTING

- A5. A minimum of 12" straight pipe is recommended from the flue outlet before turns in the vent pipe.
- A6. air pipes are to be installed with a minimum downward slope from the appliance of 1/4 inch per foot and suspended securely from overhead structures at points not greater than 3' apart.
- A7. Fasten individual lengths of vent together with at least three corrosion resistant sheet metal screws.
- A8. Keep single wall vent pipe at least 6" from combustible materials. For double wall vent pipe, follow the vent pipe manufacturer's clearances to combustibles. The minimum distance from combustible materials is based on the combustible material surface not exceeding 160°F. Clearance from the vent pipe (or the top of the unit) may be required to be greater than 6" if heat damage other than fire could result (such as material distortion or discoloration).
- A9. Avoid venting through unheated space when possible. When venting does pass through an unheated space or if the unit is installed in an environment that promotes condensation, insulate runs greater than 5' to minimize condensation. Inspect for leakage prior to insulating and use insulation that is noncombustible with a rating of not less than 400°F. Install a tee fitting at the low point of the vent system and provide a drip leg with a clean out cap as shown in Figure 15.2.
- A10. When the vent passes through a combustible INTERIOR wall or floor, a metal thimble 4" greater than the vent diameter is necessary. If there is 6' or more of vent pipe in the open space between the appliance and where the vent pipe passes through the wall or floor, the thimble need only be 2" greater than the diameter of the vent pipe. If a thimble is not used, all combustible material must be cut away to provide 6" of clearance. Where authorities have jurisdiction type B vent may be used for the last section of vent pipe to maintain clearance to combustibles while passing through wall or floor. See Figure 13.1. Any material used to close the opening must be noncombustible.

- A11. All seams and joints of un-gasketed single wall pipe must be sealed with metallic tape (3M aluminum foil tapes 433 or 363 are acceptable) or silastic suitable for temperatures up to 400°F. Wrap the tape two full turns around the vent pipe. One continuous section of double wall vent pipe may be used within the vent system. Refer to instruction A12 in "Section A – General Instructions – All Units" for attaching double wall pipe to single wall pipe.
- A12. The following are General Instructions for Double Wall (Type B) Terminal Pipe Installation. Under no circumstances should two sections of double wall vent pipe be joined together within one horizontal vent system due to the inability to verify complete seal of inner pipes.

How to attach a single wall vent terminal to double wall (type B) vent pipe:

1. Look for the "flow" arrow on the vent pipe.
2. Slide the vent terminal inside the exhaust end of the double wall vent pipe.
3. Drill (3) holes through the pipe and the vent terminal. Using 3/4" long sheet metal screws, attach the cap to the pipe. Do not over tighten.

How to connect a single wall vent system to a double wall (type B) vent pipe:

1. Slide the single wall pipe inside the inner wall of the double wall pipe.
2. Drill (3) holes through both walls of the single and double wall vent pipes. Using 3/4" sheet metal screws, attach the two pieces of pipe. Do not over tighten.
3. The gap between the single and double wall pipe must be sealed but it is not necessary to fill the full volume of the annular area. To seal, run a large bead of 400°F silastic around the gap.

- A13. Do NOT vent this appliance into a masonry chimney.
- A14. Do NOT use dampers or other devices in the vent or combustion air pipes.
- A15. The venting system must be exclusive to a single appliance, and no other appliance is allowed to be vented into it.
- A16. Precautions must be taken to prevent degradation of building materials by flue products.
- A17. Single wall vent pipe must not pass through any unoccupied attic, inside wall, concealed space, or floor.
- A18. Uninsulated single wall vent pipe must not be used outdoors for venting appliances in regions where the 99% winter design temperature is below 32°F.
- A19. Long runs of horizontal or vertical combustion air pipes may require insulation in very cold climates to prevent the buildup of condensation on the outside of the pipe where the pipe passes through conditioned spaces.
- A20. Vent termination clearances must be maintained:

Figure 13.1 - Venting Through Combustible Roof or Wall

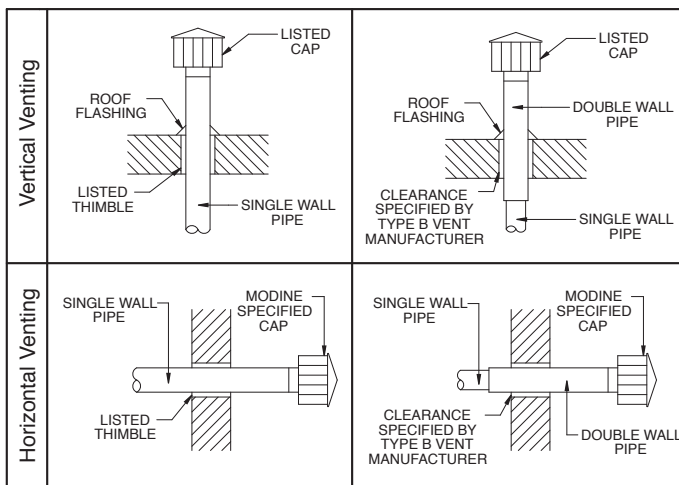

① See Instruction A12 for attaching single wall pipe to double wall pipe

INSTALLATION - VENTING

Table 14.1 - Vent Termination Clearances

Structure	Minimum Clearances for Vent Terminal Location
Forced air inlet within 10 feet	3 feet above
Combustion air inlet of another appliance	6 feet all directions
Door, window, gravity air inlet, or any building opening	4 feet horizontal and below 1 foot above
Electric meter, gas meter, gas regulator, and relief equipment ①	4 feet horizontal (U.S.) 6 feet horizontal (Canada)
Gas regulator ①	3 feet horizontal (U.S.) 6 feet horizontal (Canada)
Adjoining building or parapet wall	6 feet all directions
Adjacent public walkways	7 feet all directions
Grade (ground level)	3 feet above ②

① Do not terminate the vent directly above a gas meter or regulator.
 ② The vent must be at least 6" higher than anticipated snow depth.

- A21. Vertical combustion air pipes should be fitted with a tee with a drip leg and a clean out cap to prevent against the possibility of any moisture in the combustion air pipe from entering the unit. The drip leg should be inspected and cleaned out periodically during the heating season.
- A22. In addition to following these General Instructions, specific instructions for Vertical and Horizontal vent systems in 2-Pipe or Concentric Vent configurations must also be followed. The following outlines the differences:

Vertical Vent System Determination

- Vertical vent systems terminate vertically (up) (an example is shown in Figure 14.1).
- Determine the venting configuration as follows:
 - For two building penetrations through the wall or roof (one for the combustion air inlet pipe and one for the vent pipe), proceed to "Section B - Vertical 2-Pipe Venting".
 - For a single larger building penetration through the wall or roof, through which both the combustion air inlet and vent pipes will pass, proceed to "Section D - Horizontal and Vertical Concentric Venting".
 - For all other cases, proceed to the next section for Horizontal Vent System Determination.

Horizontal Vent System Determination

- Horizontal vent systems terminate horizontally (sideways) (an example is shown in Figure 15.2).
- Determine the venting configuration as follows:
 - For two building penetrations through the wall or roof (one for the combustion air inlet pipe and one for the vent pipe), proceed to "Section C - Horizontal 2-Pipe Venting".
 - For a single larger building penetration through the wall or roof, through which both the combustion air inlet and vent pipes will pass, proceed to "Section D - Horizontal and Vertical Concentric Venting".

Section B - Vertical 2-Pipe Vent System Installation

- B1. This section applies to vertically vented 2-pipe (one combustion air inlet pipe and one vent pipe) vent systems and is in addition to "Section A - General Instructions - All Units".
- B2. Vertical vent systems terminate vertically (up).
- B3. It is recommended to install a tee with drip leg and clean out cap as shown in Figure 14.1.
- B4. The combustion air and vent terminals must be Modine part number:
 - 5H072285-0001 (Item Code 27866) for 4" vent pipe
 - 5H072285-0002 (Item Code 27868) for 6" vent pipe
- B5. Vertical vents must terminate a minimum horizontal and vertical distance from roof lines and adjacent walls or obstructions. These minimum distances are outlined in Figure 14.1 and Table 14.2.
- B6. The vent must terminate at least 1 foot above and 16 inches horizontally from the combustion air inlet.
- B7. Once venting is complete, proceed to section titled "Installation - Gas Connections".

Figure 14.1 - Vertical Venting - 2 Pipes Sloped Roof

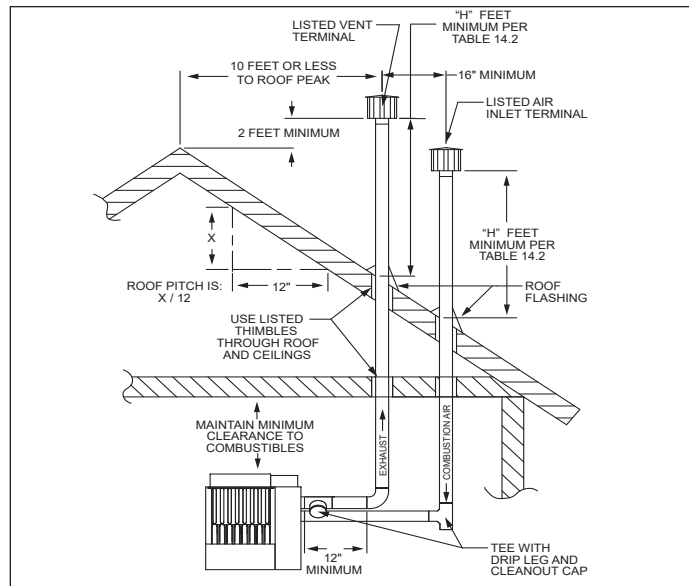

Table 14.2 - Minimum Height from Roof to Lowest Discharge Opening

Roof Rise "X" (in)	Equivalent Roof Pitch	Minimum Height "H" (ft) ①
0-10	Flat to 10/12	3.00
10-12	10/12 to 12/12	4.00
12-14	12/12 to 14/12	5.00
14-16	14/12 to 16/12	6.00
16-18	16/12 to 18/12	7.00
18-21	18/12 to 21/12	8.00

① Increase "H" as required to accommodate snow depth.

INSTALLATION - VENTING

Figure 15.1 - Vertical Venting - 2 Pipes Flat Roof

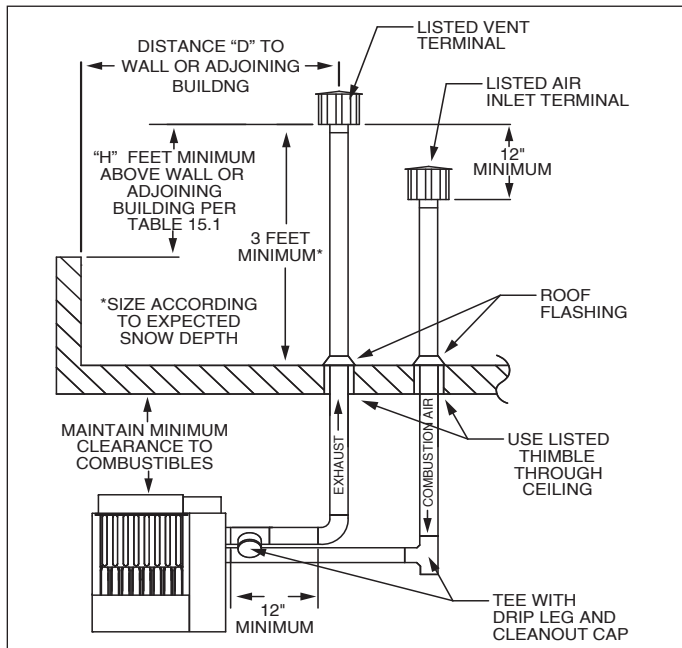

Table 15.1 - Minimum Height Above Adjacent Wall Less than 10 Feet Away

"D"	"H"
10 Feet or Less	2 Feet Minimum
Greater than 10 Feet	No Additional Height Required

Section C - Horizontal 2-Pipe Vent Installation

- C1. This section applies to horizontally vented 2-pipe vent systems (one combustion air inlet pipe and one vent pipe) and is in addition to "Section A - General Instructions - All Units".
- C2. Horizontal vent systems terminate horizontally (sideways).
- C3. Horizontal vents must be terminated with a Modine p/n:
 - 5H072285-0001 (Item Code 27866) for 4" vent pipe
 - 5H072285-0002 (Item Code 27868) for 6" vent pipe

The cap must terminate a minimum distance from the external wall, as summarized in Figure 15.2.

- C4. The termination of horizontally vented system must extend 12 inches beyond the exterior surface of an exterior wall.
- C5. The combustion air pipe must be a minimum of 16 inches below the vent pipe, and 24 inches from the exterior wall.
- C6. Construct the vent system as shown in Figure 15.2.

Figure 15.2 - Horizontal 2-Pipe Venting

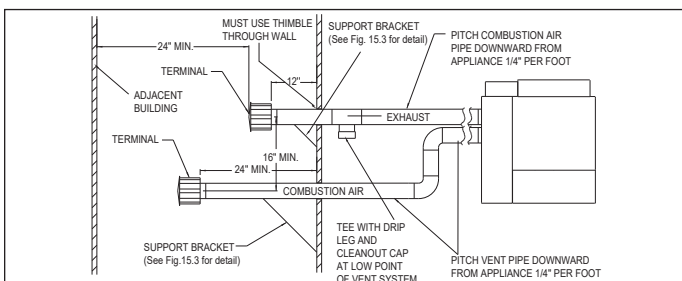

- C7. When horizontal vents pass through a combustible wall (up to 8 inches thick), the vent passage must be constructed and insulated as shown in Figure 15.3.
- C8. The vent must be supported as shown in Figure 15.3.
- C9. When condensation may be a problem, the vent system shall not terminate over public walkways or over an area where condensate or vapor could create a nuisance or hazard or could be detrimental to the operation of regulators, relief openings, or other equipment.

Figure 15.3 - Exhaust Vent Construction Through Combustible Walls and Support Bracket

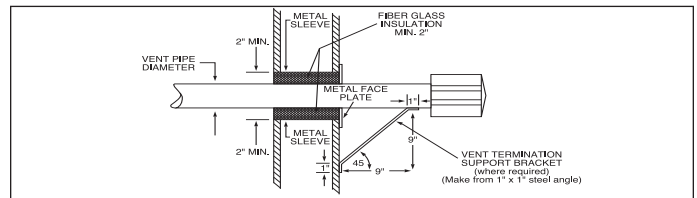

- C10. Maintain a 1/4" per foot downward slope away from the heater and place a drip leg with clean out near the exit of the vent as shown in Figure 15.2, or allow the condensate to drip out the end.
- C11. For a vent termination located under an eave, the distance of the overhang must not exceed 24". The clearance to combustibles above the exterior vent must be maintained at a minimum of 12". Consult the National Fuel Gas Code for additional requirements for eaves that have ventilation openings.
- C12. Once complete, proceed to section titled "Installation - Gas Connections".

Section D - Concentric Vent System Installation

⚠ WARNING

The concentric vent adapter box must be installed inside of the structure or building. Do not install this box on the exterior of a building or structure.

⚠ AVERTISSEMENT

La boîte adaptatrice concentrique doit être installée à l'intérieur de la structure ou du bâtiment. Elle n'est pas conçue pour être installée à l'extérieur d'un bâtiment ou d'une structure.

- D1. This section applies to both horizontally and vertically vented concentric vent systems as defined in "Section A – General Instructions – All Units", and is in addition to the instructions in that section.
- D2. When utilizing the concentric vent option, it should have been predetermined whether the appliance will be horizontally or vertically vented. Before proceeding, verify that the concentric vent kit received contains the correct components for the installation:

INSTALLATION - VENTING

For Vertically Vented Units (Refer to Figure 16.1):

Model Size (Digits 4-6)	100-175	200-400
Kit Part Number	33356 (3H0349290003)	33357 (3H0349290004)
Kit Contents	Part Number	Part Number
Concentric Vent Adapter Box	3H0373840004	3H0373840005
Outlet Vent Termination Cap	5H0722850001	5H0722850002
Combustion Air Inlet Terminal	5H0751540004	5H0751540006

Figure 16.1 - Vertical Concentric Vent Kit Components

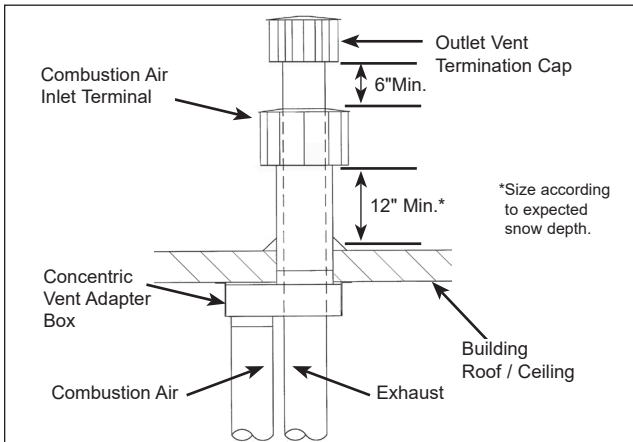

For Horizontally Vented Units (Refer to Figure 16.2):

Model Size (Digits 4-6)	100-175	200-400
Kit Part Number	32161 (3H0349300003)	32162 (3H0349300004)
Kit Contents	Part Number	Part Number
Concentric Vent Adapter Box	3H0373840004	3H0373840005
Outlet Vent Termination Cap	5H0751500001	5H0751500002
Combustion Air Inlet Guard	3H0349320004	3H0349320006

Figure 16.2 - Horizontal Concentric Vent Kit Components

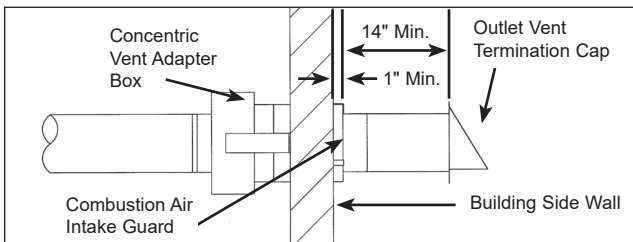

- D3. Once the kit contents have been verified as correct for the direction of venting, the concentric vent adapter box is to be installed. Determine the location of the box. Be sure to maintain all clearances as listed in these instructions.
- D4. The adapter box is to be mounted on the interior side of the building. It must not be mounted outside the building. The adapter box has integral mounting holes for ease of installation. When horizontal venting multiple units, the minimum spacing between any sides of the adapter boxes must be 18" and boxes must not overlap in the vertical plane (above or below). When condensation may be a problem, the vent system shall not terminate over public walkways or over an area where condensate or vapor could create a nuisance or hazard or could be detrimental to the operation of regulators, relief openings, or other equipment.

- D5. The adapter box can be mounted flush to the wall (for horizontal kits) or to the ceiling (for vertical kits). The box can also be offset from the wall or ceiling by using field supplied brackets. When mounting the box, consider serviceability and access to the vent and combustion air pipes. If the box is to be mounted using field supplied brackets, these brackets must be strong enough to rigidly secure the box to the wall or ceiling, and should be made from corrosion resistant material.
- D6. Determine the length of the vent pipe and combustion air inlet pipe for the selected location. THE VENT PIPE WILL PASS THROUGH THE CONCENTRIC VENT BOX. THE LAST SECTION OF VENT PIPE IS A CONTINUOUS LENGTH OF DOUBLE WALL "B" VENT. See section A12 for attaching and terminating double wall pipe. Begin with pipe lengths on the concentric pipe side of the adapter box referring to Figure 17.1. These pipes will extend through the building wall or roof as well as any added length for the thickness of the wall and the offset from any field installed brackets.

For Vertical Concentric Vent Kits (refer to Figure 16.1):

- The bottom of the combustion air intake pipe must terminate above the snow line, or at least 12 inches above the roof, whichever distance is greater.
- The bottom of the vent cap must terminate at least 6 inches above the top of the combustion air intake cap.

For Horizontal Concentric Vent Kits (refer to Figure 16.2):

- The combustion air intake pipe must terminate at least 1 inch from the wall to prevent water from running down the wall and into the pipe.
 - The back of the vent cap must terminate at least 14 inches from the combustion air intake pipe.
- D7. Cut the concentric side vent and combustion air pipes to the proper length as determined in the previous step. Note that the vent pipe diameter is 4" and the combustion air intake pipe diameter is 6" for model sizes 100-175, and 6" and 8" respectively for model sizes 200-400. The pipes must be single wall galvanized or stainless steel material, except for the last section of vent pipe, which must be one continuous length of double wall B-vent extended through the concentric vent box and combustion air inlet pipe on the concentric side of the box.
- D8. Allow the concentric side vent pipe to pass through the concentric vent adapter box, as shown in Figure 17.1. Attach the double wall vent pipe to the single wall vent pipe that goes to the unit. Be sure to seal the joint and the open area around the double wall vent. Seal all joints and seams using sealant suitable for temperatures up to 400°F.
- D9. Slide the combustion air pipe over the vent pipe and attach to the air inlet of the concentric adapter box, as shown in Figure 17.1, using at least 3 corrosion resistant sheet metal screws. Seal the joint and seam using sealant suitable for temperatures up to 400°F.

INSTALLATION - VENTING

- D10. Place this assembly (the adapter box, vent pipe and combustion air pipe) through the wall or roof and verify that the distance requirements as defined in Step D7 are met. Securely attach the assembly building.
- D11. From outside the building, caulk the gap between the combustion air intake pipe and the building penetration.
- D12. Attach the combustion air intake and vent pipe terminations as follows:

Figure 17.1 - Adapter Box with Combustion Air Intake Pipe Attached

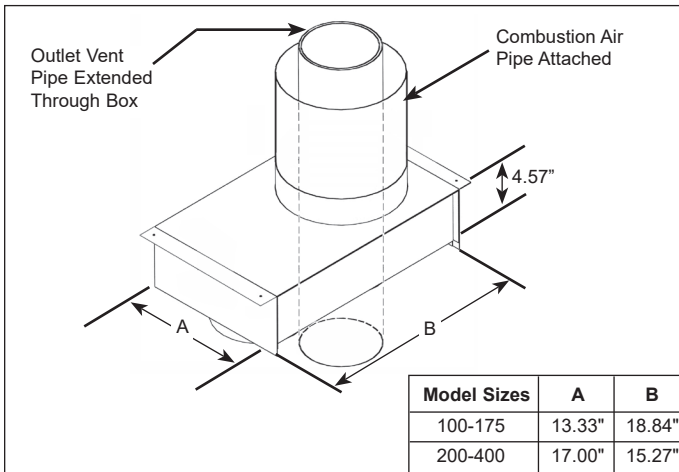

For Vertical Concentric Vent Kits (refer to Figure 16.1):

- Slide the combustion air cap down over the vent pipe and fasten it to the combustion air pipe with at least 3 corrosion resistant sheet metal screws.
- Attach the vent cap to the vent pipe using at least 3 corrosion resistant sheet metal screws. Refer to instruction A12 for connecting terminal to double wall pipe.
- Caulk the gap between the combustion air cap and the vent pipe with silicone sealant, or other appropriate sealants suitable for metal to metal contact and for temperatures up to 400° F.

For Horizontal Concentric Vent Kits (refer to Figure 16.2):

- Attach the combustion air intake guard using corrosion resistant screws at the end of the combustion air intake pipe to prevent animals and debris from entering.
 - Attach the vent cap to the vent pipe using at least 3 corrosion resistant sheet metal screws.
- D13. Install vent pipe and combustion air pipe between unit heater and concentric vent adapter box as outlined in "Section A – General Instructions – All Units".
- D14. Once venting is complete, proceed to the section titled "Installation - Gas Connections".

INSTALLATION - GAS CONNECTIONS

Gas Connections

! WARNING

1. All field gas piping must be pressure/leak tested prior to operation. Never use an open flame. Use a soap solution or equivalent for testing.
2. Gas pressure to appliance controls must never exceed 3.4 kPa (14" W.C. or 1/2 psi)
3. To reduce the opportunity for condensation, the minimum sea level input to the appliance, as indicated on the serial plate, must not be less than 5% below the rated input, or 5% below the minimum rated input of dual rated units.

! AVERTISSEMENT

1. Toutes les canalisations de gaz sur site doivent être testées (pression/fuites) avant usage. Ne recherchez jamais les fuites avec une flamme nue. Utilisez plutôt de l'eau savonneuse ou un produit équivalent.
2. La pression de gaz aux commandes de l'appareil ne doit jamais dépasser 3.4 kPa (35,5 cm C.E. ou 1/2 psi).
3. Pour réduire le risque de condensation, l'entrée minimum dans l'appareil au niveau de la mer, telle qu'indiquée sur la plaque de série, ne doit pas être moins de 5 % inférieure à la valeur d'entrée nominale des appareils à double valeur nominale.

! CAUTION

Purging of air from gas supply line should be performed as described in ANSI Z223.1 - latest edition "National Fuel Gas Code", or in Canada in CAN/CGA-B149 codes.

! ATTENTION

La purge de l'air des tuyauteries de gaz doit se faire selon la procédure ANSI Z223.1 de la dernière édition du « National Fuel Gas Code » ou des codes CAN/CGA-B149 du Canada.

IMPORTANT

To prevent premature heat exchanger failure, the input to the appliance, as indicated on the serial plate, must not exceed the rated input by more than 5%.

IMPORTANT

Pour éviter une défaillance prématurée de l'échangeur de chaleur, le pouvoir calorifique du gaz utilisé ne doit pas excéder de plus de 5 % la valeur nominale inscrite sur la plaque signalétique de l'appareil.

1. Installation of piping must conform with local building codes, or in the absence of local codes, with the National Fuel Gas Code, ANSI Z223.1 (NFPA 54) - Latest Edition. In Canada, installation must be in accordance with CAN/CGA-B149.1 for natural gas units and CAN/CGA-B149.2 for propane units.
2. Piping to units should conform with local and national requirements for type and volume of gas handled, and pressure drop allowed in the line.
3. Refer to Model Digits 4-6 of the Model Nomenclature on page 63 and the value on the unit Model ID plate

(not individual furnace serial plates) to determine the gas heating capacity in Thousands of Btu/hr (MBH). The Model ID plate is located on the blower section electrical compartment door. See Figure 18.1 for an example Model ID plate.

Figure 18.1 - Model ID Plate Example

MODEL IDENTIFICATION PLATE				MODEL NUMBER: DBS960TMRHN20F2I05DDA00	
VOLTAGE: 460V3~	HERTZ: 60	PHASE: 3	ORDER: 99999999	SERIAL NUMBER: 15100905051234-1111	SPQ: 12345678
NO. OF UNITS: 3	AMPS: 1.12	(1.5)	SHORT CIRCUIT CURRENT: 5KA	RMS SYMMETRICAL, 480V MAXIMUM	REFRIGERANT: R410A
SUPPLY VOLTAGE: 460V3~	HERTZ: 60	PHASE: 3	FILE: 5.2	INCA: 6.9	MOD. TYPE DELAY: 15

4. For the length of pipe necessary, determine the pipe diameter from Table 19.1 or Table 19.2 for the unit heating capacity. Where several units are served by the same main, the total capacity and length of main must be considered. While the gas connection(s) on the unit may be smaller than the required supply pipe diameter, do not use pipe sizes smaller than what is required leading up to the unit. At the unit, reduce the pipe size down to the appropriate size (sizes 100-225 are 1/2" connections, 250-960 are 3/4" connections). Avoid pipe sizes smaller than 1/2". The inlet pressure to the unit must be 6-7" W.C. for natural gas and 11-14" W.C. for propane gas. When sizing the inlet gas pipe diameter, be sure the unit supply pressure can be met after the line pressure drop has been subtracted. If the line pressure drop is too high, refer to NFPA 54 National Fuel Gas Code for other gas pipe capacities.
5. The gas piping to the unit can enter the unit from the side of the unit or from below. Install a ground joint union with brass seat and a manual shut-off valve external of the unit casing, and adjacent to the unit for emergency shut-off and easy servicing of controls, including a 1/8" NPT plugged tapping accessible for test gauge connection (See Figure 18.2). Verify the manual shut-off valve is gas tight on an annual basis.
6. Provide a sediment trap before each unit in the line where low spots cannot be avoided. (See Figure 18.2).

Figure 18.2 - Recommended Sediment Trap/Manual Shut-off Valve Installation - Side or Bottom Gas Connection

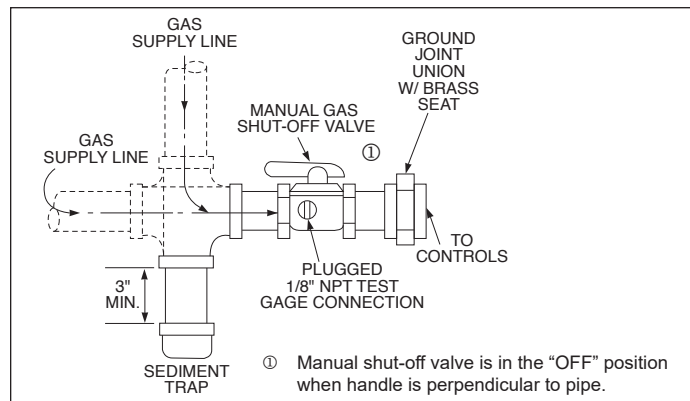

7. When Pressure/Leak testing, pressures above 14" W.C. (1/2 psi), close the field installed shut-off valve, disconnect the appliance and its combination gas control from the gas supply line, and plug the supply line before testing. When testing pressures 14" W.C. (1/2 psi) or below, close the manual shut-off valve on the appliance before testing.

INSTALLATION - GAS CONNECTIONS

Table 19.1 - Gas Pipe Capacities - Natural Gas ①

Pipe Length (ft)	Capacity in MBH by Nominal Pipe Diameter							
	1/2"	3/4"	1"	1 1/4"	1 1/2"	2"	2 1/2"	3"
10	138	287	540	1,113	1,659	3,203	5,103	9,009
20	95	197	371	762	1,145	2,195	3,507	6,195
30	76	159	298	612	917	1,764	2,814	4,977
40	65	135	255	524	784	1,512	2,405	4,253
50	58	120	226	464	695	1,344	2,132	3,770
60	53	109	205	420	630	1,218	1,932	3,423
70	48	100	188	386	580	1,113	1,775	3,150
80	44	93	175	360	540	1,038	1,659	2,930
90	42	87	165	338	506	974	1,554	2,741
100	40	83	155	319	478	921	1,470	2,594
125	35	74	138	282	423	816	1,302	2,300
150	32	66	125	256	384	739	1,176	2,079
175	29	61	114	235	353	680	1,082	1,911
200	27	57	107	219	329	632	1,008	1,785
250	24	50	95	194	291	561	894	1,575

① Gas pipe capacities based on Table 19.1.1(a) of NFPA 54 for schedule 40 metallic pipe with inlet pressure less than 2 psi, with a pressure drop of 0.3" w.c. and gas specific gravity of 0.60.

Table 19.2 - Gas Pipe Capacities - Propane Gas ②

Pipe Length (ft)	Capacity in MBH by Nominal Pipe Diameter							
	1/2"	3/4"	1"	1 1/4"	1 1/2"	2"	2 1/2"	3"
10	291	608	1,150	2,350	3,520	6,790	10,800	19,100
20	200	418	787	1,620	2,420	4,660	7,430	13,100
30	160	336	632	1,300	1,940	3,750	5,970	10,600
40	137	287	541	1,110	1,660	3,210	5,110	9,030
50	122	255	480	985	1,480	2,840	4,530	8,000
60	110	231	434	892	1,340	2,570	4,100	7,250
80	101	212	400	821	1,230	2,370	3,770	6,670
100	94	197	372	763	1,140	2,200	3,510	6,210
125	89	185	349	716	1,070	2,070	3,290	5,820
150	84	175	330	677	1,010	1,950	3,110	5,500
175	74	155	292	600	899	1,730	2,760	4,880
200	67	140	265	543	814	1,570	2,500	4,420
250	62	129	243	500	749	1,440	2,300	4,060

② Gas pipe capacities based on Table 19.2.1(d) of NFPA 54 for schedule 40 metallic pipe with inlet pressure of 11.0" w.c., with a pressure drop of 0.5" w.c. and gas specific gravity of 1.50.

Table 19.3 - Burner Orifice Sizing and Gas Consumption

Model Size		Gas Type		Orifice Qty
		Natural ①	Propane ②	
100	Cfh	96.1	40.0	2
	Orifice Drill Size	30	45	
125	Cfh	120.2	50.0	2
	Orifice Drill Size	25	42	
150	Cfh	144.2	60.0	3
	Orifice Drill Size	30	45	
175	Cfh	168.3	70.0	3
	Orifice Drill Size	27	43	
200	Cfh	192.3	80.0	3
	Orifice Drill Size	23	42	
225	Cfh	216.3	90.0	3
	Orifice Drill Size	20	39	
250	Cfh	240.4	100.0	4
	Orifice Drill Size	25	42	
300	Cfh	288.7	120.0	4
	Orifice Drill Size	20	39	
350	Cfh	336.5	140.0	6
	Orifice Drill Size	27	43	
400	Cfh	384.6	160.0	6
	Orifice Drill Size	23	42	
500 ③	Cfh	240.4	100.0	4
	Orifice Drill Size	25	42	
600 ③	Cfh	288.7	120.0	4
	Orifice Drill Size	20	39	
700 ③	Cfh	336.5	140.0	6
	Orifice Drill Size	27	43	
800 ③	Cfh	384.6	160.0	6
	Orifice Drill Size	23	42	
840 ④	Cfh	336.5	140.0	6
	Orifice Drill Size	27	43	
960 ④	Cfh	384.6	160.0	6
	Orifice Drill Size	23	42	

① Based on natural gas properties of 1050 Btu/ft³ and specific gravity of 0.60.

② Based on propane gas properties of 2500 Btu/ft³ and specific gravity of 1.50.

③ Model sizes 500-800 contain 2 furnaces. Values shown are per furnace.

④ Model sizes 840-960 contain 3 furnaces. Values shown are per furnace.

INSTALLATION - GAS CONNECTIONS

Considerations for Elevation

The standard ratings for Models DBS/DCS are certified for elevations up to 2,000 feet above sea level. Operation at elevations above 2,000 feet requires ratings be reduced 4% for each 1,000 feet above sea level per ANSI Z223.1. The exception is for units in Canada, CSA requires that ratings be reduced 10% for elevations between 2,001 and 4,500 feet. The following instructions are for units that will be installed over 2,000 feet elevation. Unit can be operated up to a maximum of 10,000 feet (3,048 m).

Manifold Pressure Adjustment

The unit manifold pressure is factory set for operation at elevations up to 2,000 feet as follows:

- For Natural Gas units, 3.5" W.C. based on a gas heating value of 1,050 BTU/ft³.
- For Propane Gas units, 10.0" W.C. based on a gas heating value of 2,500 BTU/ft³.

For higher elevations, some utility companies may derate the BTU content (heating value) of the gas provided at altitude to a lower value to allow certain heating appliances to be used with no manifold pressure adjustments. For this reason it is necessary that the supplying utility be contacted for detailed information about the gas type and BTU content (heating value) before operating any heater. Table 20.1 shows the standard derated heating values of natural and propane gases at various elevations.

Table 20.1 - Gas Heating Values at Altitude (Btu/ft³)

① ② ③ ④ ⑤

Altitude (ft)	Natural Gas	Propane
0-2,000	1,050	2,500
2,001-3,000	929 ③	2,212 ④
3,001-4,000	892 ③	2,123 ④
4,001-4,500	874 ③	2,080 ④
4,501-5,000	856	2,038
5,001-6,000	822	1,957
6,001-7,000	789	1,879
7,001-8,000	757	1,803
8,001-9,000	727	1,731
9,001-10,000	698	1,662

① Values shown are for 3.5" W.C. manifold pressure for Natural Gas and 10.0" W.C. for Propane Gas. If the local utility supplies gas with a different Btu/ft³ value, use Equation 20.1 to calculate the required manifold pressure.

② Gas heating values shown are derated 4% per 1,000' of elevation (10% between 2,000' and 4,500' elevation in Canada) in accordance with ANSI Z223.1 and CSA-B149, respectively.

③ 945 Btu/ft³ for Canada

④ 2,250 Btu/ft³ for Canada

⑤ When installed at altitudes above 2,000', a pressure switch may need to be changed. Refer to Table 20.2 to determine if a switch change is required.

If the utility is supplying gas with heating values SAME as shown in Table 20.1, the manifold pressure should remain set to 3.5" W.C. for natural gas and 10.0" W.C. for propane gas and you may proceed to the section on this page titled "Selection of the Proper High Altitude Kit".

If the utility is supplying gas with heating values DIFFERENT than shown in Table 20.1, use Equation 20.1 to determine the appropriate manifold pressure for the elevation and gas heating value being supplied. Note what that value is, as it will be needed later for Start-Up. Proceed to the section on this page titled "Selection of the Proper High Altitude Kit".

Equation 20.1 - Manifold Pressure for Gas Heating Values Different Than Shown in Table 20.1

$$MP_{ELEV} = \left(\frac{BTU_{TBL}}{BTU_{ACT}} \right)^2 \times MP_{SL}$$

Where:

MP_{ELEV} = Manifold Pressure (" W.C.) at installed elevation

BTU_{TBL} = BTU/ft³ content of gas from Table 20.2

BTU_{ACT} = BTU/ft³ content of gas obtained from the utility company

MP_{SL} = Manifold Pressure (" W.C.), at Sea Level (use 3.5" W.C. for natural gas and 10.0" W.C. for propane)

Note: For units equipped with two-stage or modulating gas controls, only the high fire manifold pressure needs to be adjusted. No adjustments to the low fire manifold pressure are necessary on these units.

All units installed at elevations greater than 2000 feet above sea level require a kit, in addition to potential manifold pressure adjustment outlined in the previous step. To determine the proper kit to use, refer to Table 20.2. For more information, refer to the latest revision of Modine Bulletin 75-530.

Table 20.2 - High Altitude Kit Selection Table ① ② ③ ④

Model Size	Item Code by Elevation Above Sea Level (ft)						
	2,001-2,500	2,501-4,500	4,501-5,000	5,001-5,500	5,501-6,500	6,501-7,000	7,001-7,500
100	67248	67248	67248	67248	77785	77785	68406
125	67248	77786	77786	77786	77785	77785	68406
150	77787	77786	77786	77786	77785	77785	68406
175	77786	77786	68408	68408	68408	68410	68410
200	67248	67248	67248	67248	67248	67248	67248
225	67248	67248	67248	67248	67248	67248	67248
250/500	67248	67248	67248	67248	67248	67248	67248
300/600	67248	67248	67248	67248	67248	67248	67248
350/700/840	67248	67248	67248	77786	77785	77785	68406
400/800/960	77786	77786	77785	77785	77785	68410	68410

① Applies to both installations in the U.S. and Canada.

② Applies to both natural and propane gas.

③ Sizes 100-400 require a kit qty. of 1, sizes 500-800 require a kit qty of 2, sizes 840-960 require a kit qty of 3.

④ All kits include a High Altitude Conversion Label and Installation Instructions. Additionally, all kits except 67248 include a Pressure Switch to replace the standard switch.

If a unit is to be installed at higher elevations AND converted from natural gas to propane gas operation, a propane conversion kit must be used in conjunction with the manifold pressure adjustment and high altitude kit listed above. For the Selection and Installation Instructions for propane conversion kits, please see the latest revision of Modine Bulletin 75-511.

INSTALLATION - ELECTRICAL CONNECTIONS

Electrical Connections

WARNING

1. Disconnect power supply before making wiring connections or working on this equipment. Follow all applicable safety procedures to prevent accidental power up. Failure to do so can result in injury or death from electrical shock or moving parts and may cause equipment damage.
2. All appliances must be wired strictly in accordance with wiring diagram furnished with the appliance. Any wiring different from the wiring diagram could result in a hazard to persons and property.
3. Any original factory wiring that requires replacement must be replaced with wiring material having a temperature rating of at least 105°C.
4. Ensure that the supply voltage to the appliance, as indicated on the serial plate, is not 5% greater than rated voltage.

AVERTISSEMENT

1. Débranchez l'alimentation électrique avant d'effectuer des connexions ou de travailler sur l'appareil. Respectez toutes les procédures de sécurité qui s'appliquent pour éviter toute mise en marche accidentelle. Le non-respect de cette directive peut entraîner des blessures ou la mort causées par un choc électrique ou des pièces mobiles, en plus d'endommager l'appareil.
2. Tous les appareils doivent être branchés de manière strictement conforme au diagramme fourni. Tout câblage différent de celui du schéma peut créer des risques de dommages matériels ou de blessures.
3. Tout câblage usine d'origine exigeant un remplacement doit être remplacé par un câble d'indice thermique nominal de 105 °C.
4. Assurez-vous que la tension d'alimentation de l'appareil, comme indiqué sur la plaque de série, n'est pas de 5 % supérieure à la tension nominale.

CAUTION

1. Ensure that the supply voltage to the appliance, as indicated on the serial plate, is not 5% less than the rated voltage.
2. Do not reuse any mechanical or electrical component which has been wet. Such components must be replaced.

ATTENTION

1. Vérifiez que la tension d'alimentation de l'appareil n'est pas inférieure de plus de 5 % à la tension nominale inscrite sur la plaque de série.
 2. Ne tentez pas de réutiliser un composant mécanique ou électrique qui a été mouillé. Ces composants doivent être remplacés.
1. Installation of wiring must conform with local building codes, or in the absence of local codes, with the National Electric Code ANSI/NFPA 70 - Latest Edition. Unit must be electrically grounded in conformance to this code. In Canada, wiring must comply with CSA C22.1, Part 1, Electrical Code.

2. Two copies of the job specific wiring diagram are provided with each unit, one located in the duct furnace electrical junction box and one in the electrical section of the unit. Refer to this diagram for all wiring connections.
3. External electrical connections to be installed include:
 - Supply power (120, 208, 240, 480, or 600 volts).
 - Thermostats, remote monitoring panels, building pressure sensors, time clocks, or any other accessory control devices that may be supplied (24 volts).
4. All supply power electrical connections are made in the electrical section of the unit. The low voltage (thermostat and accessory control devices) can be wired to either the electrical section or the duct furnace electrical junction box. Refer to the wiring diagram for the terminal location of all low voltage wiring.
5. Refer to the unit dimensional drawings in this document for the location of the drill locator dimples in the side and bottom of the unit for field drilling the hold for the electrical conduit entry.
6. Control wiring consists of both 24V analog control wiring and for models with Model Digit 12=9, low current digital control signal wiring. To avoid signal interference, the two types should be run in conduit separate from power wiring. The analog control wiring should be shielded at one end of the wiring run. Wiring should be stranded, twisted, and shielded communication wire.
7. The wire gauge must be sized according to the National Electric Code or CSA code based on the power supply voltage, amp draw, and length of run. Refer to the Table 21.1 for maximum wire lengths.

Table 21.1 - 24V and Digital Control Wire Lengths

Minimum Recommended Wire Gauge	Maximum Distance (feet) from Control Device to Unit	
	24V Control Wiring	Digital Control Wiring
22	n/a	120
20	n/a	200
18	75	300
16	125	500
14	175	n/a

8. **FOR UNITS WITH MODEL DIGIT 12=9 (MODINE CONTROL SYSTEM OPTION):** For field wiring to the factory terminal strip, the terminal strip connections are designed to clamp down on the wires. To properly connect the wires to the terminal strip:
 - Push a small flat-head screwdriver into the square hole on the terminal. Press firmly until the screwdriver hits the back stop and opens the terminal (see Figure 22.1).
 - Remove approximately 3/8" of insulation from the end of the wire and push the stripped wire into the oval hole in the terminal.
 - Remove the screwdriver. Pull on the wire to make sure that it is securely clamped in the terminal.
 - Make sure that the terminal clamp is in contact with bare wire (insulation removed).

INSTALLATION - ELECTRICAL CONNECTIONS

Figure 22.1 - Terminal Strip Wiring (Model Digit 12=9)

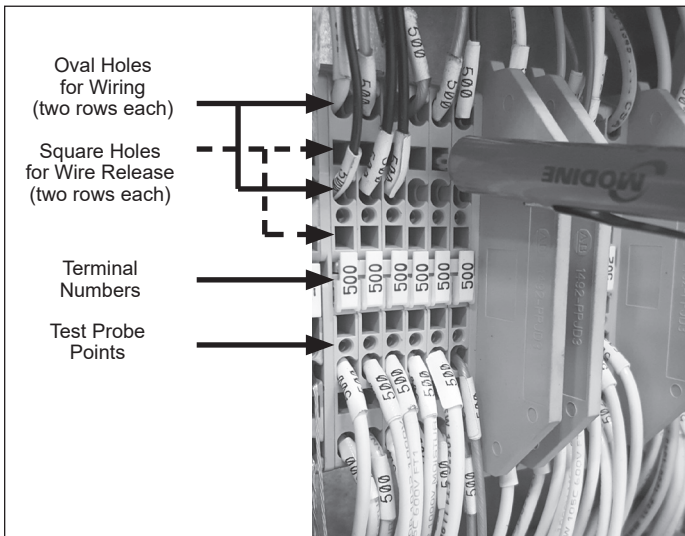

9. Depending on the configuration of the unit controls, there may be sensors that are field installed. Review the unit ordered to verify that the sensors supplied match the configuration of the unit. The following are sensors that may be included for field installation (for installation instructions, refer to the instructions included with the individual sensors):

- **Supply Air Temperature Sensor**
This sensor is required on all units and is mounted in the supply air ductwork downstream of the unit discharge.
- **Outdoor Air Sensor**
This sensor is required on all units except 100% return air units. The sensor is duct mounted in the inlet ductwork.
- **Return Air Sensor**
This sensor is required on all units that have a mixture of outside and return air. The sensor is mounted in the return air ductwork.
- **Space Temperature/Humidity Sensor**
This sensor is required on all units that have space temperature/humidity reset control.
- **Duct Pressure Sensor**
This sensor is required on all units that have duct pressure control through variable frequency drive control on the supply air blower.
- **Space CO2 Sensor**
This sensor is required on all units that have demand based ventilation control based on space CO2 concentration.
- **Duct Mounted Smoke Detector**
This sensor is mounted in the supply air or return air ductwork.

For further instructions on the above sensor(s), refer to the installation instructions that shipped with the sensor(s).

10. Make sure all multi-voltage components (motors, transformers, etc.) are wired in accordance with the power supply voltage.

11. The power supply to the unit must be protected with a fused or circuit breaker disconnect switch. Refer to the Factory Mounted disconnect switch location and then review the unit to determine if a factory installed dead front disconnect switch was provided. Accessory field installed disconnect switches should be mounted where required by the National Electric Code as shown in Figure 22.2. For fusible disconnect switches, refer to the Model Identification plate for the fuse size and type.
12. The power supply must be within 5% percent of the voltage rating and each phase must be balanced within 2 percent of each other. If not, advise the utility company.
13. All outdoor electrical connections must be weatherized to prevent moisture from entering the electrical compartment.

Figure 22.2 - Recommended Field Installed Disconnect Switch Mounting Location

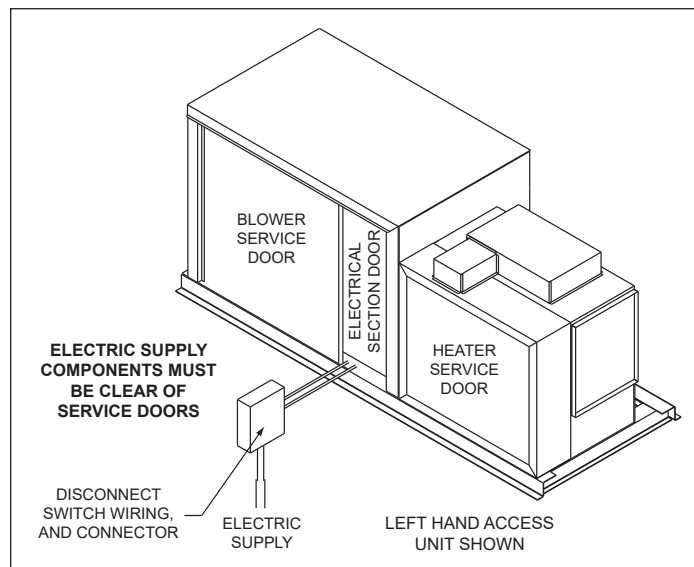

THIS PAGE INTENTIONALLY LEFT BLANK

INSTALLATION - COOLING COIL UNITS

Cooling Coil Units

Models with a cooling section can be provided with a factory installed direct expansion (DX) evaporator or the coil can be field supplied and installed by others. For units equipped with a factory installed cooling coil (Digit 23 = 1), refer to the packing slip to determine the coil type provided.

The cooling section includes a full coverage, 3-way sloping 409 stainless steel drain pan to remove condensate from coil headers, thermal expansion valves, and refrigerant piping. Insulation is standard on outdoor units and optional on indoor units. The cabinet includes two doors, a removable upper door for service access to the coil once the plumbing has been installed and a lower door which includes a factory supplied 1" (2.54 cm) stubbed drain connection to the exterior of the cabinet. Field connections for coil inlet and outlet piping can be made through the cabinet corner post or back of the unit. The cooling section duct transition includes 1.5" (3.81 cm) flanges for fastening the sides of the coil. The bottom duct transition is angled to remove any condensation that may be entrained in the supply air stream.

For field supplied coils, do not exceed the maximum coil dimensions listed in Literature 82-135. The dimensions listed are for the maximum coil dimensions. If the coil supplied is smaller than the listed dimensions, field supplied blank off plates are required to prevent air bypass around the coil. The coil is supported by two 14 gauge support rails which contain mounting provisions for fastening 4" (10 cm), 5" (12.70 cm), 6" (15.24 cm), 7.5" (19.05"), and 10" (25.4 cm) deep coils.

Figure 24.1 - Cooling Section

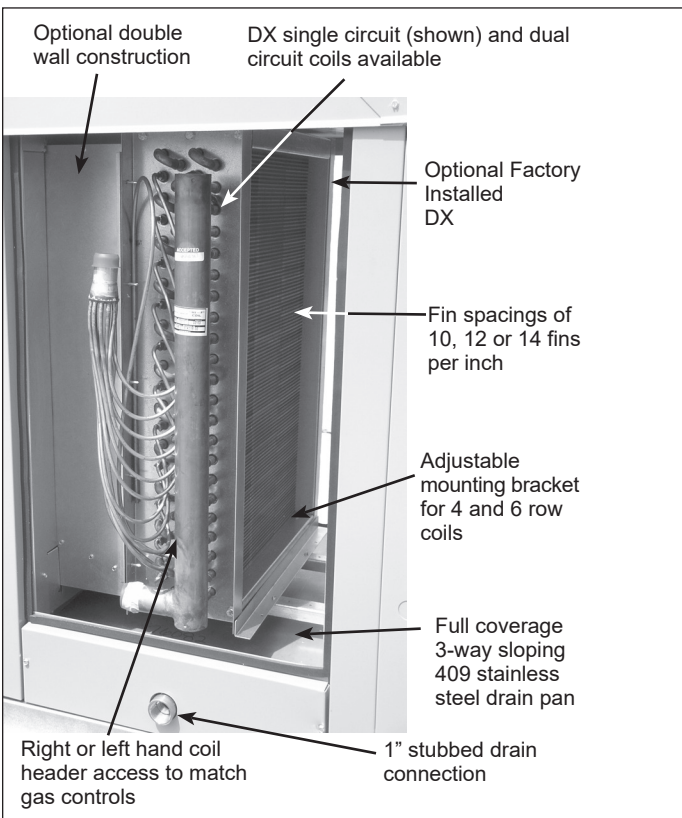

Condensate Drain Pan Trap

The condensate drain line needs to include a P-trap immediately downstream of the connection to the unit. This trap should extend at least two inches (5.08 cm) below the connection to prevent air pressure from forcing air into the unit. The trap should be primed with a water/glycol solution to prevent freezing.

Direct Expansion (DX) Piping

The refrigerant lines should be insulated to prevent warming or cooling of the refrigerant. If the suction line is allowed to be cooled, liquid will condense in the line and can severely damage the compressor. If the liquid line is warmed, the refrigerant can "flash" into a gas. This will cause erratic operation of the expansion device and impair the heat transfer ability of the cooling coil. Long runs of piping need to be periodically supported to prevent excess vibration that can damage the piping and joints. It is recommended to provide dampening supports at intervals of length equivalent to 15 tube diameters.

Figure 24.2 - General DX Piping

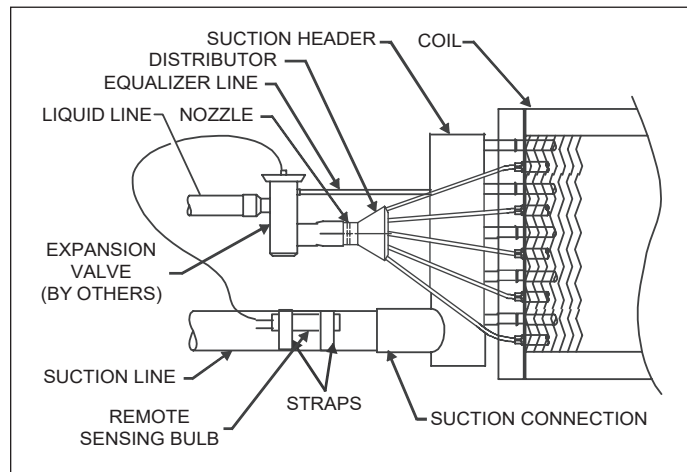

(continued on next page)

INSTALLATION - COOLING COIL UNITS

1. Inspect the refrigerant distributor and verify that the nozzle is in place.
2. All field brazing and welding should be performed using high quality materials and an inert gas purge (such as nitrogen) to reduce oxidation of the internal surface of the coil.
3. For DX coils, the use of filter-dryers in the system piping is recommended along with a sight glass that has a moisture indicator.
4. Connect the suction line and suction connection.
5. Install the expansion valve (By Others). Follow the expansion valve manufacturer's recommendations for installation to avoid damaging the valve.
6. Connect the liquid line to the expansion valve. Pressurize the coil, expansion valve assembly and suction connection to 100 psig with dry nitrogen or other suitable gas. The coil should be left pressurized for a minimum of 10 minutes.
7. If the coil holds pressure, the installation can be considered leak free. If the pressure drops by 5 psi or less, repressurize the coil and wait another 10 minutes. If the pressure drops again, there are more than likely one or more small leaks, which should be located and repaired. Pressure losses greater than 5 psi would indicate a larger leak, which should be isolated and repaired. Be sure to check valves and fittings as potential sites for leakage or bleed.
8. Use a vacuum pump to evacuate the coil and any interconnecting piping that has been open to atmosphere. Measure the vacuum in the piping using a micron gauge located as far from the pump as possible (the vacuum at the pump will be greater than the rest of the system). Evacuate the coil to 500 microns or less then close the valve between the pump and the system. If the vacuum holds to 500 microns or less for one minute, the system is ready to be charged or refrigerant pumped down in another portion of the system can be opened to the coil. A steady rise in microns would indicate that moisture is still present and that the coil should be further vacuumed until the moisture has been removed.
9. Failure to obtain a high vacuum is indicative of a great deal of moisture or a small leak. Break the vacuum with a charge of dry nitrogen or other suitable gas and recheck for leaks (soapy water works well). If no leaks are found, continue vacuuming the coil until the desired vacuum is reached.
10. All field piping must be self-supporting.

Table 25.1 - Cooling Coil Performance Limits

Cooling Type	Model Size	Min CFM	Single Circuit		Dual Circuit		Max Cooling (Tons) ②
			Max CFM ①	Area (ft²)	Max CFM ①	Area (ft²)	
DX	100	802 ③	2,206	4.01	2,048	3.72	11.4
	125	937					
	150	1,125	2,521	4.58	2,416	4.39	13.4
	175	1,312					
	200	1,500	3,352	6.09	3,165	5.76	18.1
	225	1,687					
	250	1,875	3,724	6.77	3,538	6.43	20.2
	300	2,250					
	350	2,625	5,214	9.48	4,996	9.08	27.3
	400	3,000					

① Based on 550 feet per minute (FPM) coil face velocity.

② Based on 95°F/75°F Entering Dry Bulb/Wet Bulb.

③ Model Size 100 minimum CFM for DX Dual Circuit is 745.

START-UP PROCEDURE

Start-Up Procedure

IMPORTANT

1. To prevent premature heat exchanger failure, observe heat exchanger tubes by looking at the heat exchanger through the field installed access openings in connecting ductwork in blower package units or the unit access doors in cooling package units. If the bottom of the tubes become red while blower and duct furnace are in operation, check to be sure the blower has been set to the proper rpm for the application. Refer to page 29 for Blower Adjustments.
2. Start up and adjustment procedures, installation, and service of these appliances must be performed by a qualified installation and service agency.

IMPORTANT

1. Pour éviter la défaillance prématurée de l'échangeur de chaleur, examinez les tubes de l'échangeur de chaleur en le regardant à travers les ouvertures d'accès installées sur les lieux lors de la connexion des tuyaux ou les portes d'accès à l'unité où il est possible de voir l'échangeur de chaleur. Si le bas des tubes devient rouge lorsque la soufflante et la chaudière canalisée sont en marche, vérifiez que le régime de la soufflante est approprié pour l'application. Pour le réglage de la soufflante, reportez-vous à la page 29.
2. Les procédures de démarrage et de réglage, l'installation et le service de ces appareils doivent être confiés à un centre d'installation et de service qualifié.

Refer to page 61 for the Start-up Checklist.

1. Turn off power to the unit at the disconnect switch. Check that fuses or circuit breakers are in place and sized correctly. Turn all hand gas valves to the "OFF" position.
2. Remove the duct furnace and blower exterior panels and open the electrical compartment door.
3. Check that the supply voltage matches the unit supply voltage listed on the Model Identification plate. Verify that all wiring is secure and properly protected. Trace circuits to insure that the unit has been wired according to the wiring diagram.
4. Check to insure that the venting system is installed and free from obstructions.
5. Check to see that there are no obstructions to the intake and discharge of the unit.
6. Check the belt tension and sheave alignment. Refer to Blower Adjustments for proper belt tension.
7. Check bearings for proper lubrication. For units provided with pillow block bearings (See Model Nomenclature), refer to Lubrication Recommendations for lubrication requirements.
8. Check to make sure that all filters are in place and that they are installed properly according to direction of air flow.
9. Perform a visual inspection of the unit to make sure no damage has occurred during installation.
10. Turn on power to the unit at the disconnect switch. Check to insure that the voltage between duct furnace electrical box terminals 1 and 2 is 24V.
11. Check the thermostat, ignition control, gas valve, and supply fan blower motor for electrical operation. If these do not function, recheck the wiring diagram. Check to insure that none of the Control Options have tripped.
12. For units with a return air damper, the return air damper linkage needs to be adjusted. Refer to Damper Linkage Adjustment.
13. Check to make sure that the damper opens properly without binding.
14. Check the blower wheel for proper direction of rotation when compared to the air flow direction arrow on the blower housing. Blower wheel rotation, not air movement, must be checked as some air will be delivered through the duct furnace with the blower wheel running backwards.
15. Check the blower speed (rpm). Refer to Blower Adjustments for modification.
16. Check the motor speed (rpm).
17. Check the motor voltage. On three phase systems, check to make sure all legs are in balance.
18. Check the motor amp draw to make sure it does not exceed the motor nameplate rating. On three phase systems, check all legs to insure system is balanced.
19. Recheck the gas supply pressure at the field installed manual shut-off valve. The minimum inlet pressure should be 6" W.C. on natural gas and 11" W.C. on propane gas. The maximum inlet pressure for either gas is 14" W.C. If inlet pressure exceeds 14" W.C., a gas pressure regulator must be added upstream of the combination gas valve.
20. Open the field installed manual gas shut-off valve.
21. Open the manual main gas valve on the combination gas valve. Call for heat with the thermostat and allow the pilot to light. On a call for heat the power exhauster relay will energize the power exhauster motor. Once the power exhauster motor reaches full speed, a differential pressure switch will close before the pilot can light. If the pilot does not light, purge the pilot line. If air purging is required, disconnect the pilot line at outlet of pilot valve. In no case should line be purged into heat exchanger. Check the pilot flame length (See Pilot Flame Adjustment).
22. Once the pilot has been established, check to make sure that the main gas valve opens. Check the manifold gas pressure (See Main Gas Adjustment) and flame length (See Air Shutter Adjustment) while the supply fan blower is operating.
23. Check to insure that gas controls sequence properly (See Control Operating Sequence). Verify if the unit has any additional control devices and set according to the instructions in the Control Options.
24. Once proper operation of the unit has been verified, remove any jumper wires that were required for testing.
25. Close the electrical compartment door.
26. Replace all exterior panels.

START-UP PROCEDURE

Pilot Burner Adjustment

The pilot burner is orificed to burn properly with an inlet pressure of 6-7" W.C. on natural gas and 11-14" W.C. on propane gas. Final adjustment must be made after installation. If the pilot flame is too long or large, it may cause soot and/or impinge on the heat exchanger causing failure. If the pilot flame is too short, it may cause poor ignition or result in the controls not opening the combination gas control. A short flame can be caused by a dirty pilot orifice. The pilot flame should be observed periodically to assure trouble-free operation.

To Adjust the Pilot Flame

1. Create a call for heat from the thermostat.
2. Remove the cap from the pilot adjustment screw. For location, see the combination gas control literature supplied with unit.
3. Adjust the pilot length by turning the screw in or out to achieve a soft steady flame 3/4" to 1" long and encompassing 3/8"-1/2" of the tip of the thermocouple or flame sensing rod (See Figure 27.1).
4. Replace the cap from the pilot adjustment screw.

Figure 27.1 - Correct Pilot Flame

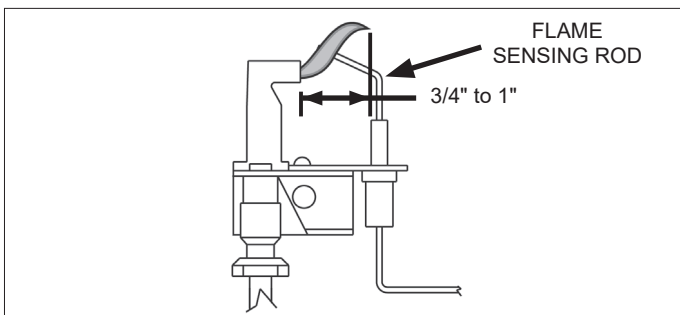

Main Burner Adjustment

The gas pressure regulator (integral to the combination gas control) is adjusted at the factory for average gas conditions. It is important that gas be supplied to the duct furnace in accordance with the input rating on the serial plate. Actual input should be checked and necessary adjustments made after the duct furnace is installed. Over-firing, a result of too high an input, reduces the life of the appliance and increases maintenance. Under no circumstances should the input exceed that shown on the serial plate.

Check/Adjust Pressure at the Combination Gas Valve

This section applies to all units, regardless of gas control type.

1. Turn the field installed manual shut-off valve to "OFF".
2. Remove the 1/8" pipe plug in the pipe tee or gas valve and attach a U-tube type water manometer which is at least 12" high and capable of reading to 0.1" W.C. See Figure 33.1.
3. Turn the field installed manual gas shut-off valve to "ON".

Figure 27.2 - Checking Manifold Pressure with "U" Tube Manometer

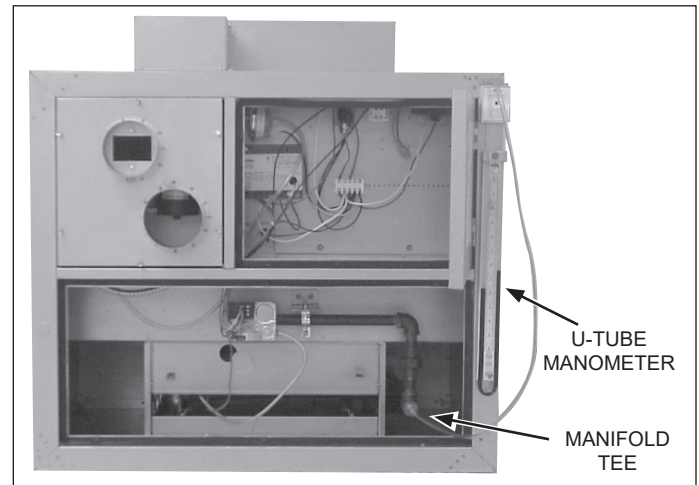

4. Create a high fire call for heat from the thermostat.
5. Determine the correct high fire manifold pressure, which depends on gas type and gas control type. Review the furnace Model Digit 11 and 12 (not the system model number) and adjust the main gas pressure regulator spring to achieve the proper manifold pressure as shown in Table 27.1. For location of regulator adjustment, refer to the combination gas control literature supplied with the unit.

Table 27.1 - Manifold Gas Pressure - Main Valve

Furnace Model Digit 11	Furnace Model Digit 12	Manifold Pressure
N (Natural)	1, 2, 4, 7	3.5"
	9 ①	4.0"
P (Propane)	1, 2, 4, 7	10.0"
	9 ①	10.5"

① For units with Model Digit 12=9 and multiple furnaces, only one furnace will be Model Digit 12=9, the additional furnaces will be Model Digit 12=2, therefore pressures will be different for those furnaces.

6. If the unit has Electronic Modulation gas controls (Model Identification Digit 12=4, 7, or 9), skip steps 7 through 9 in this section and proceed to the next section "Check/Adjust Pressure for the Modulating Valve", otherwise continue to the next step.
7. After adjustment, move the field installed manual shut-off valve to the "OFF" position, remove the manometer, and replace the 1/8" pipe plug.
8. After the plug is in place, move the field installed manual shut-off valve to the "ON" position and recheck pipe plugs for gas leaks with soap solution.
9. Proceed to the section "Air Shutter Adjustment".

START-UP PROCEDURE

Check/Adjust Pressure for the Modulating Valve

This section only applies to units with Electronic Modulation gas controls (Model Identification Digit 12=4, 7, or 9). Refer to the appropriate instructions for the valve type on the unit.

For Units with Model Digit 12=4 or 7

The low fire gas pressure needs to be adjusted. This needs to be repeated on each furnace in multiple furnace units. Using Figure 28.1 for item locations, this is accomplished as follows:

1. Disconnect power.
2. Remove all wires from Maxitrol Amplifier terminal "3" or duct furnace terminal "43" (if available).
3. Turn on power at the disconnect switch.
4. Remove the maximum adjustment screw (4), spring (5), and plunger (8). A small magnet is useful for this purpose. CAUTION - The plunger is a precision part. Handle carefully to avoid marring or picking up grease and dirt. Do not lubricate.
5. Using minimum adjusting screw (9), adjust low fire manifold pressure to 0.56" W.C. for natural gas and 1.6" W.C. for propane gas.
6. Replace plunger and spring retainer, spring, and maximum adjusting screw in proper order.
7. Using maximum adjustment screw (4), adjust high fire manifold pressure to 3.5" W.C. for natural gas and 10" W.C. for propane gas.
8. Disconnect power.
9. Replace cover plate (2) and re-install all wires from Maxitrol amplifier terminal "3" or duct furnace terminal "43".
10. After adjustment, move the field installed manual shut-off valve to the "OFF" position and replace the 1/8" pipe plug.

Figure 28.1 - Maxitrol Modulating Valve Adjustments

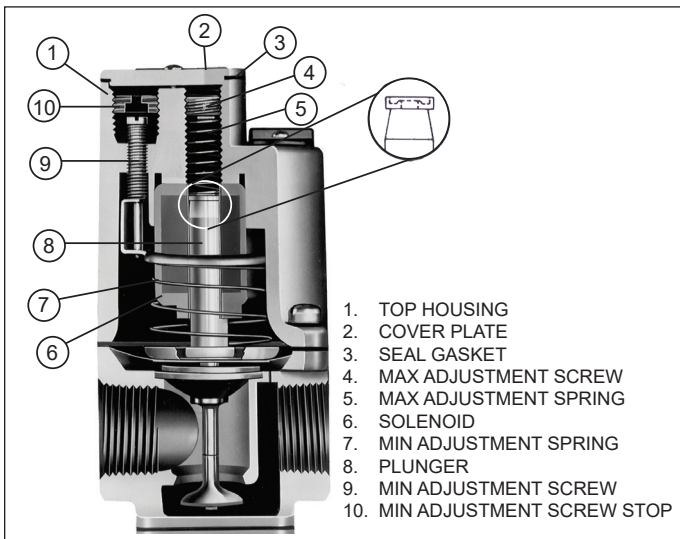

11. After the plug is in place, move the field installed manual shut-off valve to the "ON" position and recheck pipe plugs for gas leaks with soap solution.
12. Proceed to the section "Air Shutter Adjustment".

For Units with Model Digit 12=9:

The high fire gas pressure needs to be adjusted first, followed by the low gas pressure. For multiple furnace units, this is only required on the duct furnace that has the modulating valve (Model Digit 12=9). This is accomplished as follows:

1. Verify the main valve (valve before the modulating valve) outlet pressure has been set to 4.0" W.C. for natural gas or 10.5" W.C. for propane gas per instructions and Table 27.1 on the previous page. For multiple furnace units, the furnaces without the modulating valves are to remain at 3.5" W.C. for natural gas or 10.0" W.C. for propane gas. For location of regulator adjustment, refer to the combination gas control literature supplied with the unit.
2. The Maxitrol EXA modulating valve series has a cover secured with two screws that must be removed. Once removed, there are a bank of (3) DIP switches and two buttons and a communication LED for the user interface as shown in Figure 29.1.
3. Verify that the DIP switches are properly set to the "OFF" position for switches 1 and 3 and "ON" for switch 2.
4. Adjust the High Fire Setting as follows:
 - a. Enable the unit controls and create a call for heat.
 - b. Press and hold Button #1 on the modulating valve until the LED lights solid red, then release.
 - c. With the valve now in the high fire setting mode, confirm or adjust the high fire manifold pressure to be 3.5" W.C. If the pressure needs to be adjusted, press or hold Button #1 to increase gas flow and press or hold Button #2 to decrease gas flow.
 - d. If 3.5" W.C. cannot be attained, recheck the inlet gas pressure as described previously. After addressing any issues, if 3.5" W.C. still cannot be attained, step the valve closed using button #2 to the point where manifold pressure begins to be impacted. If the pressure at that point is less than 3.3" W.C., recheck your inlet pressure with the unit operating and adjust as required.
 - e. Save the setting by simultaneously holding Buttons #1 and #2 until the LED turns OFF. If this is not performed within 5 minutes, the control will default to the previously saved settings and return to normal operating mode.
5. Adjust the Low Fire Setting as follows:
 - a. Press and hold Button #2 on the modulating valve until the LED light blinks red, then release.
 - b. With the valve now in the low fire setting mode, confirm or adjust the low fire manifold pressure to be no less than the minimum shown on the furnace serial plate in the box called "Min. Manifold Pressure". If the pressure needs to be adjusted:
 - c. Press or hold Button #1 to increase gas flow and #2 to decrease gas flow. It is best to push and release button #2 to single step the valve to the minimum manifold pressure. Holding the button is likely to cause the valve to close too far and lose flame.
 - d. Save the setting by simultaneously holding Buttons #1 and #2 until the LED turns OFF. If this is not performed within 5 minutes, the control will default to the previously saved settings and return to normal operating mode.

START-UP PROCEDURE

6. Once the setting of the modulating valve has been completed, replace the valve cover removed earlier.
7. Move the field installed manual shut-off valve to the "OFF" position, remove the manometer, and replace the 1/8" pipe plug.
8. After the plug is in place, move the field installed manual shut-off valve to the "ON" position and recheck the pipe plug for gas leaks with soap solution.
- 9.. Proceed to the section "Air Shutter Adjustment".

Figure 29.1 - Maxitrol EXA Modulating Valve

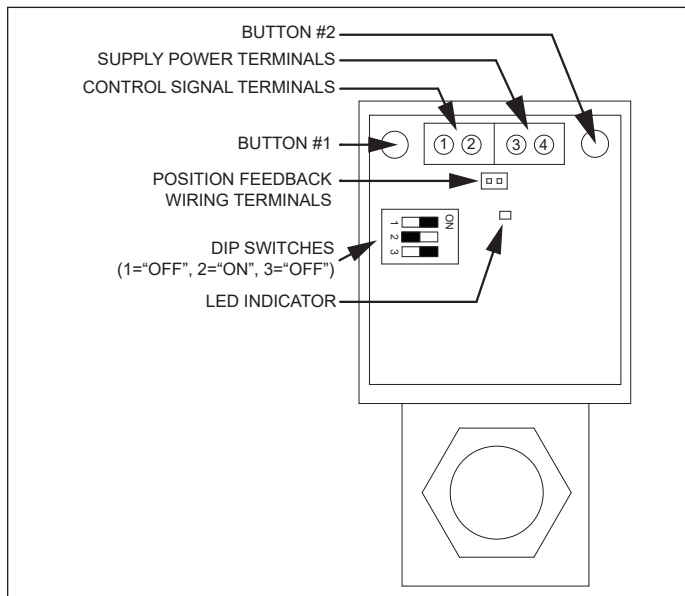

Air Shutter Adjustment

Proper operation provides a soft blue flame with a well-defined inner core. A lack of primary air will reveal soft yellow-tipped flames. Excess primary air produces short, well-defined flames with a tendency to lift off the burner ports. For both natural and propane gas, the air shutters can be adjusted to control the burner flame height. The air shutters can be accessed by reaching behind the manifold tee in Figure 57.1. The larger models may require the removal of the manifold (see Manifold Assembly Removal).

Adjusting the primary combustion air is achieved by resetting the primary air shutters (See Figure 57.1). Prior to flame adjustment, operate duct furnace for about fifteen minutes. The main burner flame can be viewed after loosening and pushing aside the gas designation disc on the side of the burner box.

1. To increase primary air, loosen the air shutter set screws and move the air shutters closer to the manifold until the yellow tipped flames disappear and a clean blue flame with a well defined inner cone appears.
2. To decrease primary air, move the air shutters away from the manifolds until flames no longer lift from burner ports, but being careful not to cause yellow tipping.
3. Re-tighten set screws after adjustment.

Blower Adjustments

If blower fan speed changes are required, adjust motor sheave as follows:

1. Refer to page 45 to page 47 to determine correct blower speed according to job requirements, then proceed with steps 2 through 8.
2. Loosen motor base and take belt off of motor sheave.
3. Loosen set screw on outer side of adjustable motor sheave.

Figure 29.2 - Motor Sheave Adjustment

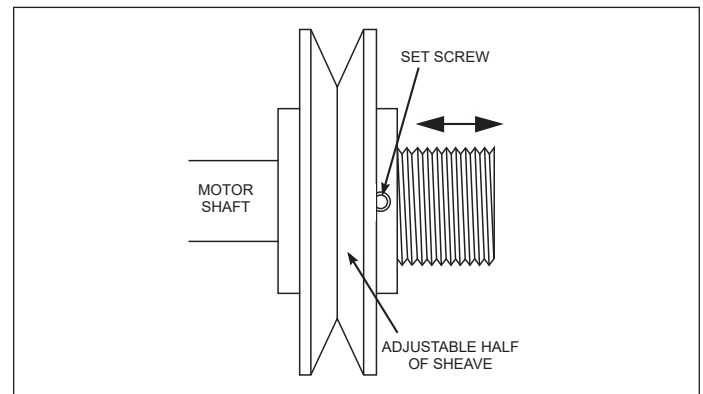

4. Turn outer side of motor sheave clockwise until motor sheave is fully closed.
5. From fully closed position, turn outer side of motor sheave counterclockwise until the proper number of turns open are achieved.
6. Retighten motor sheave set screw, replace belt and retighten motor base. Motor base should be shifted for proper belt tension which is 3/4" deflection with about 5 lbs. of force.

Figure 29.3 - Belt Tension Adjustment

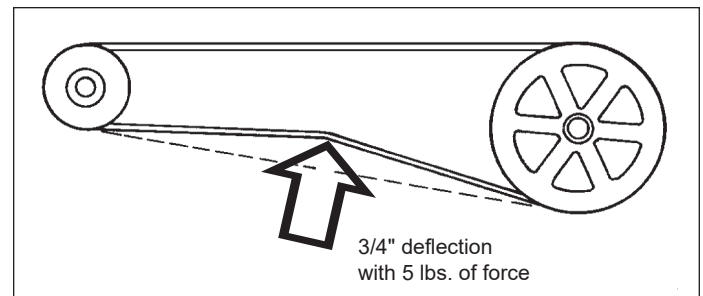

7. Recheck blower rpm after adjustment.

Note: Do not fire unit until blower adjustment has been made or unit may cycle on high limit control.

8. Check motor amps. Do not exceed nameplate amps shown on motor nameplate.

START-UP PROCEDURE

Lubrication Recommendations

The blower can be provided with either spider or pillow block bearings. Spider bearings are permanently lubricated and do not require lubrication. Pillow block bearings are shipped greased from the factory but will require lubrication. The bearings should be checked and lubricated before each heating season but a more frequent lubrication schedule may be required based on the environment in which the unit is installed, and the frequency of the equipment operation. Shell Alvania #2 lubricant is recommended.

Damper Linkage Adjustment

If the unit is provided with a return air damper, to prevent shipping damage, the return air damper linkage is disconnected and the damper closed. Before operating the unit, the fresh and return air dampers must be connected. This is accomplished by the following:

1. The damper actuator should be de-energized and the fresh air damper in a fully closed position.
2. Open the return air damper in a fully open position.
3. Slide the connecting rod into the ball joint on the blade arm with the return air damper fully open. See Figure 30.1.
4. Tighten the 5/16" hex head screw on the ball joint.

Figure 30.1 - Damper Linkage Adjustment

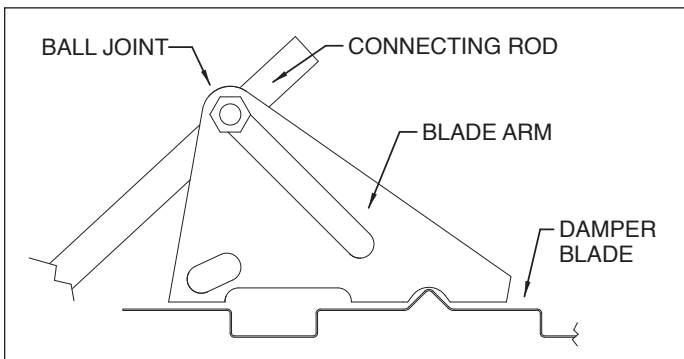

Furnace Control Operating Sequence

IMPORTANT

To prevent premature heat exchanger failure, with all control systems, a blower starting mechanism must be provided so that the blower is running or energized within 45 seconds of the gas control operation.

IMPORTANT

Pour éviter la panne prématurée de l'échangeur thermique, avec tous les systèmes de commande, un mécanisme de démarrage de la soufflerie doit être fourni pour que la soufflerie démarre dans les 45 secondes qui suivent l'activation de la commande de gaz.

Furnaces are supplied with intermittent pilot systems with continuous retry, which both the main burner and pilot burner are turned off 100% when the thermostat is satisfied.

Gas Control Options (see page 34) could change the listed sequence of operation based on their function.

The descriptions given are for the basic duct furnace.

Single Furnace Controls

Single furnace units (Model Digits 4-6=100 through 400) are offered with different types of gas control:

- **Staged Control (Model Digit 12=1 or 2):** These furnaces utilize a single- or two-stage combination gas valve, an ignition control, and a low voltage thermostat.
- **Electronic Modulating Control (Model Digit 12=4 or 7):** These furnaces utilize a single-stage combination gas valve, an electronic modulating gas valve, a modulating amplifier, an ignition control, and one of the following:
 - Modulating room thermostat
 - Modulating duct thermostat with remote temperature set point adjuster
 - Building Management System (BMS) signal by others (an inverted signal where 0VDC is high fire and 10VDC is low fire).
- **Electronic Modulating Control with Modine Control System (Model Digit 12=9):** These furnaces utilize a single-stage combination gas valve, an electronic modulating gas valve, a programmable microprocessor based controller, an ignition control, and different sensors depending on the application, but most commonly include:
 - A duct temperature sensor
 - A space temperature sensor
 - There is also BMS integration capability for BACnet or LonWorks protocol systems.

START- UP PROCEDURE

The control operating sequence for all furnaces is as follows:

1. The thermostat calls for heat or is enabled by the BMS.
2. The power exhauster relay is energized starting the power exhauster motor. Once the motor has reached full speed, the differential pressure switch closes. The power exhauster pre-purge time delay relay then closes after 20 to 40 seconds and energizes the gas control circuit.
3. The pilot valve opens and the spark igniter sparks in an attempt to light the pilot. The system will attempt to light the pilot for 70 seconds. If the pilot is not sensed for any reason, the ignition control will wait for approximately six minutes with the combination gas control closed and no spark. After six minutes, the cycle will begin again. After three cycles, some ignition controllers lockout for approximately one hour before the cycle begins again. This will continue indefinitely until the pilot flame is sensed or power is interrupted to the system.
4. Once the pilot is lit, the flame sensor proves the pilot and stops the spark igniter from sparking.
5. The main gas valve is opened and the main burner is controlled as follows:
 - **Single-Stage Furnaces (Model Digit 12=1):** The main burner is lit to 100% full fire.
 - **Two-Stage Furnaces (Model Digit 12=2):** The main burner is lit to 50% fire. If the temperature at the thermostat continues to fall, the thermostat will call for high stage heat and the main burner is lit to 100% full fire.
 - **Modulating Room or Duct Thermostat (Model Digit 12=4):** The main gas valve is opened 100% and the burner firing rate is modulated between 40% and 100% full fire. A resistance signal (8000 to 12000 ohms) in the thermostat is converted by the modulating amplifier to an inverted DC voltage (between 0VDC for high fire to 12 VDC for low fire) and applied to the modulating gas valve to control the gas flow to the main burner.

Note: *When modulating duct sensing is utilized, a room override thermostat can be added. When the room override calls for heat, the burner modulates to full fire operation until the room override is satisfied. The unit then reverts back to duct sensing control. When equipped with both, either the duct sensor or the room override thermostat can call for heat.*

- **BMS Signal (Model Digit 12=7):** The main gas valve is opened 100% and the burner firing rate is modulated between 40% and 100% full fire. A BMS 0-10VDC signal (inverted, such that 0 VDC is high fire and 10VDC is low fire) is converted by the signal conditioner/modulating amplifier into an inverted DC voltage (between 0VDC for high fire to 12VDC for low fire) and applied to the modulating gas valve to control the gas flow to the main burner. The signal conditioner can accept a 0-10VDC signal when all the dip switches are in the "OFF" position.

Note: *For further information regarding the operation of any of the electronic modulating system options above, consult the literature provided with the unit.*

- **Modulating with Modine Control System (Model Digit 12=9):** The main gas valve is opened 100% and the burner firing rate is modulated between 40% and 100% full fire. Heating demand is determined by the Modine Control System through a comparison of the supply air or space temperature to setpoint and a DC voltage (between 2VDC for low fire to 10 VDC for high fire) is applied to the modulating gas valve to control the gas flow to the main burner.

Note: *Typically the temperature control is via supply air with the space sensor used to reset the supply air temperature setpoint. For additional information, refer to the Modine Control System Manual, literature #74-510 that shipped with the unit.*

6. If the unit was provided with a time delay relay, the blower starts after 30 to 45 seconds.
7. Once the temperature is satisfied, both the main and pilot valves close 100%. Blower operation may or may not continue, depending on application.

Multiple Furnace Controls

Multiple furnace units are available as two furnace units (Model Digits 4-6=500 through 800) and three furnace units (Model Digits 4-6=840 or 960) and with different types of gas control:

- **Staged Control (Model Digit 12=1):** For control of multiple staged furnaces, each furnace would be individually controlled. Refer to the section for Single Furnace Controls, Staged Control (Model Digit 12=1).
 - Two furnace units would be controlled as 2-stage (50%/50%).
 - Three furnace units can be controlled as 3-stage (33%/33%/33%) or 2-stage (33%/67%).
- **Electronic Modulating Control (Model Digit 12=4):** For control of multiple electronic modulating furnaces, one furnace is the Primary furnace featuring a modulating amplifier capable of driving modulating gas valves on Secondary furnaces. Because all valves are driven by one amplifier, all valves modulate at the same rate, from 40% to 100% full fire. Refer to the section for Single Furnace Controls, Electronic Modulating Gas Controls (Digit 12=4).
- **Electronic Modulating Control (Model Digit 12=7):** For control of multiple electronic modulation furnaces for BMS control (0-10VDC control signal), each furnace would be individually controlled. Refer to the section for Single Furnace Controls, Electronic Modulation Control (Model Digit 12=7).
- **Modulating with Modine Control System (Model Digit 12=9):** For control of multiple furnaces, one furnace features a modulating gas valve while additional furnaces are two stage furnaces. The Modine Control system seamlessly stages furnaces and modulates the primary furnace based on demand.

START- UP PROCEDURE

Variable Air Volume Applications

Units may be supplied with variable frequency drives for applications where variable air volume is required. The minimum air flow may be reduced to as low as 30% of the full speed air flow, but not lower than the minimum airflow listed in Table 32.1 and Table 42.1, unless certain conditions are followed. Refer to the following section titled "Extended VAV Airflow Limits" for additional information.

To determine the actual minimum allowable airflow, all unit selections must be performed with the AccuSpec configuration software. Within AccuSpec, multiple variable frequency drive speed control changeover options are available, which include these common selections:

- Two speed which may be controlled by a manual high/low switch which may be factory mounted on the control panel or shipped loose for field installation or by exhaust fan interlocks.
- Building management control which allows for an external signal of 0-10VDC to adjust the unit airflow.

Additional options are available when the unit is configured with the Modine Control System option (Model Digit 12=9).

Extended VAV Airflow Limits

If certain conditions are followed, the allowable minimum CFM of the system can be extended to:

- 75% of the minimum listed CFM in Table 42.1 for high air temperature rise units (Model Digit 10=H)
- 66% of the minimum listed CFM in Table 42.1 for low air temperature rise units (Model Digit 10=L).

Refer to Table 32.1 for a summary of the reduced minimum airflows, indicated in the column "Extended Range". To allow the reduced airflows, the unit must be applied as follows:

1. The unit has 2-stage or modulating gas controls.
2. The unit is provided with a discharge air thermostat.
3. The system does not include a room thermostat.
Exception: See note below for units equipped with the Modine Control System option (Model Digit 12=9).

The discharge air thermostat will prevent the unit from firing above the allowable 100°F rise when the unit is at or above the minimum CFM by monitoring the discharge air and going to low fire. A room thermostat, because it is located remote from the unit, could cause the unit to over-fire.

Note: For units equipped with the Modine Control System option (Model Digit 12=9): A space temperature sensor (Carel pAD) is permitted, as a call for heating from the space results in a reset of the supply air temperature setpoint that will still maintain a supply temperature that is at or below the maximum allowable discharge air temperature.

Table 32.1 - Extended Range VAV Minimum Airflow

Input Rating (Digit 4-6)	Minimum Airflow (CFM)			
	High ATR (Digit 10=H)		Low ATR (Digit 10=H)	
	Standard	Extended Range ①	Standard	Extended Range ②
100	750	563	1,250	825
125	938	703	1,563	1,031
150	1,125	844	1,875	1,238
175	1,313	984	2,188	1,444
200	1,500	1,125	2,500	1,650
225	1,688	1,266	2,813	1,856
250	1,875	1,406	3,125	2,063
300	2,250	1,688	3,750	2,475
350	2,625	1,969	4,375	2,888
400	3,000	2,250	5,000	3,300
500	-	-	3,125	2,063
600	-	-	3,750	2,475
700	-	-	4,375	2,888
800	-	-	5,000	3,300
840	-	-	6,562	4,331
960	-	-	7,500	4,950

① Extended range minimum can be 75% of standard minimum.

② Extended range minimum can be 66% of standard minimum.

Cooling Coil Operation

1. Proper air distribution is vital to coil performance. Air flow anywhere on the coil face should not vary by more than 20%.
2. Air velocities should be maintained between 200 and 550 feet per minute. Refer to Table 25.1.

COMPONENT LOCATIONS

Figure 33.1 - Factory Mounted Option Locations

1. Discharge Thermostat (not shown)
2. Low Gas Pressure Switch
3. High Gas Pressure Switch
4. Power Exhauster Assembly
5. Timed Freeze Protection
6. Ignition Controller
7. Differential Pressure Switch
8. Control Relay
9. Time Delay Relay
10. Furnace Low Voltage Terminal Strip
11. Power Exhauster Relay
12. Furnace Supply Power Terminal Strip
13. Control Step Down Transformer
14. Control Relay
15. Blower Low Voltage Terminal Strip
16. Dead Front Disconnect Switch
17. Step Down Transformer Fuses
18. Step Down Transformer
19. Factory Installed Minimum Positioner
22. Return Air Fire Stat
23. Blower Housing
24. Pillow Block Bearings
25. Blower Motor
26. Filters
27. Fresh Air Damper
30. Direct Drive Damper Actuator
32. Damper to Damper Linkage
33. Return Air Damper
35. Motor and Blower Vibration Isolation
36. Blower Support
37. Convenience Outlet
38. Blower Door Switch
39. Dirty Filter Switch
40. Motor Starter
41. Mild Temperature Thermostat
43. Warm-Up Stat
44. Blower Supply Power Terminal Strip
46. Electronic Modulating Amplifier
47. Electronic Modulating Gas Valve
48. Air Flow Proving Switch
49. High Limit Switch
50. Supply Air Fire Stat
51. Main Gas Valve
52. Burner Box

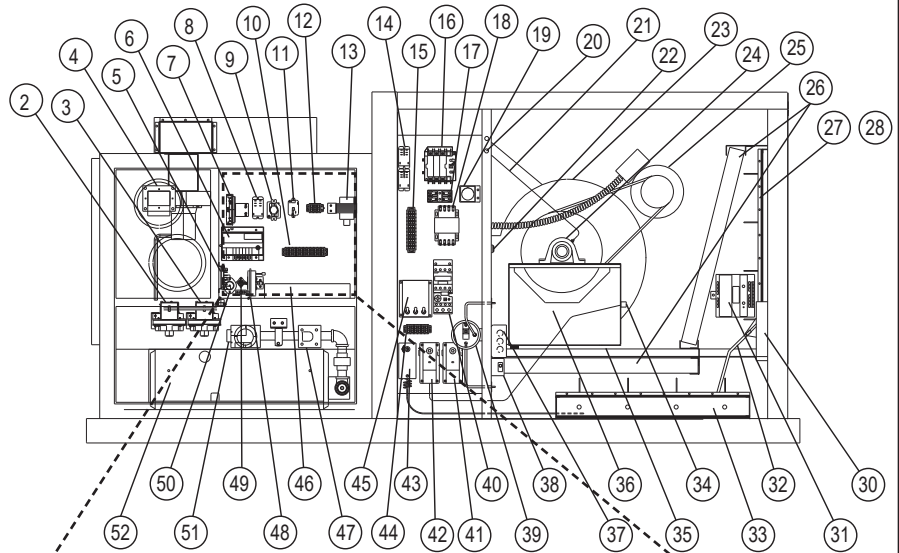

**Furnace Control Panel(s) for
Modine Control System Equipped Units (Model Digit 12=9)**

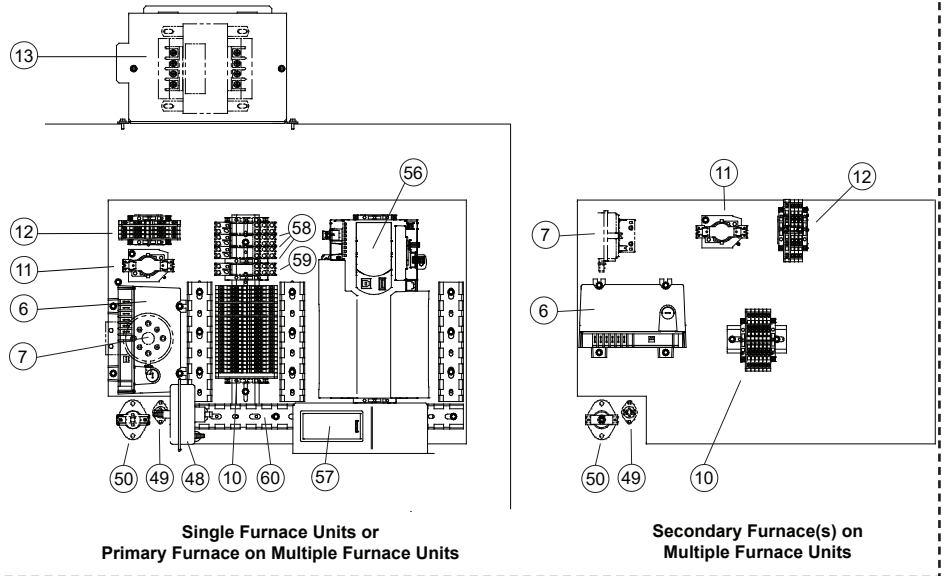

**For Modine Control System Units Only
(Model Digit 12=9):**

56. Carel pCOEM+ Microprocessor Controller
57. Carel pLDPro User Interface Panel
58. Optional Control Relays
59. Optional Unit Enable Relay
60. Wiring Channels
61. Return Air Sensor (not shown)
62. Outside Air Sensor (not shown)
63. Mixed Air Sensor (not shown)
64. Carel pGD1 Digital Display/Interface Module (not shown)

COMPONENT DESCRIPTIONS

COMPONENT DESCRIPTIONS

All units include the standard (STD) features. The unit must be reviewed to determine the optional (OPT) features that may have been supplied with the unit.

(1) Discharge Thermostat/Sensor – (OPT)

The discharge thermostat or sensor is field installed in the discharge (supply) air ductwork. For additional information, refer to the thermostat vendor literature provided in the literature packet with the unit. Model Sizes 500-960 contain multiple furnaces so multiple thermostats/sensors may be include

- a. **Two-Stage Electronic Thermostat (Digit 12=1 or 2)**
The thermostat body is field installed remotely and includes the discharge air set point adjuster that must be field set. Refer to Literature 5-577 latest revision.

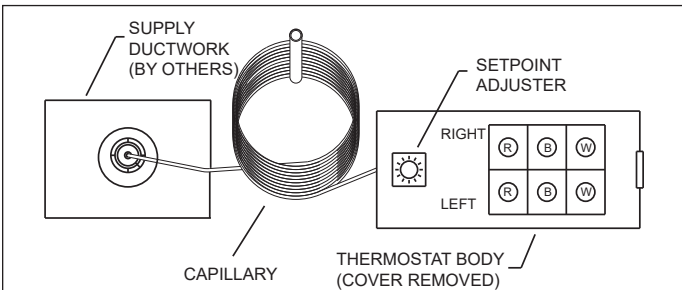

- b. **Two-Stage Electronic Thermostat (Digit 12=1 or 2)** The thermostat body is field installed remotely and includes the discharge air set point adjuster that must be field set. Refer to Literature 5-577 latest revision.



Note: Second stage S350 module not shown.

- c. **Electronic Modulating Discharge Sensor (Digit 12=4)** Includes a field installed mixing tube and discharge air sensor field installed in duct work. The set point adjuster is field installed remotely and must be field set. Refer to Literature 5-578 latest revision for instructions.

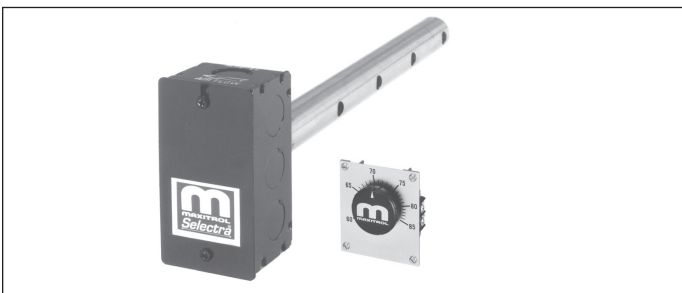

- d. **Supply Air Sensor (Model Digit 12=9) (not shown)**
Used on units with Modine Control System option, the sensor is field installed in duct work. Refer to Literature 74-541 latest revision for instructions.

(2) Low Gas Pressure Switch – (OPT)

The switch monitors the gas pressure upstream of all the gas controls and disables the ignition controller and combination gas valve if low gas pressure is experienced. The switch is automatic reset, allowing the unit to operate when gas pressure returns above the minimum setpoint. The switch should be set to insure that the minimum inlet gas pressure is available (6" W.C. for natural gas, 11" W.C. for propane gas).

(3) High Gas Pressure Switch – (OPT)

The switch monitors the gas pressure downstream of all the gas controls and disables the ignition controller and combination gas valve if high gas pressure is experienced right before the manifold. The switch is manual reset so that if the gas pressure is too high, a service person must check the unit to be sure the gas controls have not been damaged, then reset the switch to allow the unit to operate when gas pressure returns below the maximum setpoint. The switch should be set to insure that the maximum manifold gas pressure is not exceeded (3.5" W.C. for natural gas, 10" W.C. for propane gas).

Figure 34.1 - Low and High Gas Pressure Switches

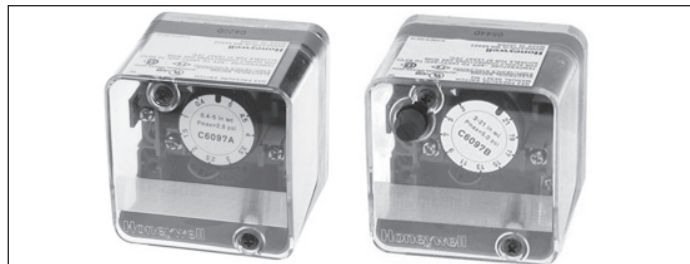

(4) Duct Furnace Power Exhauster – (STD)

The power exhauster is factory installed in the duct furnace section. On a call for heat, the power exhauster creates a combustion draft through the duct furnace prior to the pilot being energized. The draft is proven through a differential pressure switch that closes when the motor reaches full speed. For information about venting, refer to "Installation - Venting" section.

(5) Timed Freeze Protection (OPT) (All Except Digit 12=9)

The timed freeze protection system includes a sensor factory installed in the discharge air stream. On initial start-up, the timed delay in the system allows the unit to go through the normal ignition sequence. The timed delay is a manual reset switch and adjustable for 1-10 minutes. In the event that the unit fails to fire after this period, the discharge air sensor will sense the cold air (30°-75°F adjustable) and will shut down the unit.

Figure 34.2 - Timed Freeze Protection Module

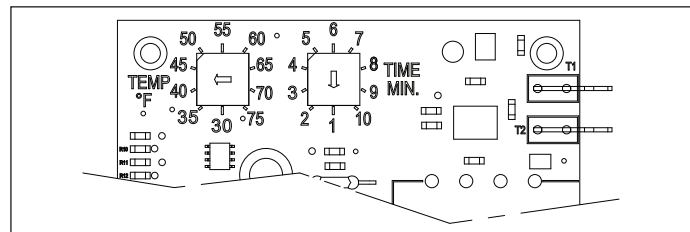

For units with the Modine Control System option (Model Digit 12=9), this feature is integral to the control logic and utilizes existing sensors included with that option. Refer to the latest revision of the Modine Control System Manual, literature 74-510 for additional information.

COMPONENT DESCRIPTIONS

(6) Ignition Controller – (STD)

The ignition controller is factory installed in the duct furnace electrical junction box with the spark ignitor and sensor located on the burner. For both natural and propane gas units, the ignition controller is 100% shut-off with continuous retry. On a call for heat, the system will attempt to light the pilot for 70 seconds. If the pilot is not sensed for any reason, the ignition control will wait for approximately six minutes with the combination gas control closed and no spark. After six minutes, the cycle will begin again. After three cycles, some ignition controllers lockout for approximately one hour before the cycle begins again. This will continue indefinitely until the pilot flame is sensed or power is interrupted to the system.

(7) Differential Pressure Switch - (STD)

The differential pressure switch is factory installed in the duct furnace electrical junction box. The differential pressure switch monitors the pressure differential between the duct furnace vent discharge and the atmosphere and disables the gas controls if vent pressure measured by the switch is not adequate to close the switch. This could be caused by a blocked combustion air inlet vent pipe.

(8) Control Relay – (OPT)

The control relay is factory installed in the duct furnace electrical junction box. The relay has a 24V coil with double-pole, double throw (DPDT) contacts. Refer to the unit wiring diagram for the function of the switching operation of the relay. The two normally open and two normally closed contacts are rated for a maximum of 30 amps @ 115V/1Ph.

(9) Time Delay Relay – (STD)

The time delay relay is factory installed in the duct furnace electrical junction box. The time delay relay allows the gas controls to operate for approximately 30 seconds before the blower starts. This allows the heat exchanger a warm up period so that the initial delivered air coming out of the ductwork is not cool. The time delay relay also keeps the motor running for approximately 30 seconds after the call for heat has been satisfied to remove the residual heat from the heat exchanger. For single phase units below 1-1/2 Hp, the time delay relay controls the motor directly. For single phase units 1-1/2 Hp and greater and all three phase units, the time delay relay controls the motor starter.

(10) Furnace Low Voltage Terminal Strip – (STD)

The furnace low voltage terminal strip is located in the duct furnace electrical junction box. The terminal strip is labeled to match the electrical wiring diagram provided with the unit. Low voltage labeling ranges from terminal numbers 1 to 79. All field wiring connections should be made to the top side of the terminals to prevent miswiring by modifying the factory wiring which is made to the bottom of the terminal strip.

(11) Power Exhauster Relay - (STD)

The control relay is factory installed in the duct furnace electrical junction box. On a call for heat, the relay coil is energized resulting in the contacts energizing the power exhauster motor.

(12) Furnace Supply Power Terminal Strip – (STD)

The furnace supply power terminal strip is located in the duct furnace electrical junction box. The terminal strip is labeled to match the electrical wiring diagram provided with the unit. Supply power labeling ranges from terminal numbers 80 to 99. All field wiring connections should be made to the bottom side of the terminals to prevent miswiring by modifying the factory wiring which is made to the top of the terminal strip.

(13) Control Step Down Transformer – (STD)

The control step down transformer is located in the duct furnace electrical junction box. The transformer is used to step down the supply power (115V, 208V, 230V, 460V, 575V) to 24V. This transformer is used to control the gas controls, damper actuator, motor starter, etc. Refer to the unit model number to determine the volt-amp (VA) capacity of the duct furnace. The 15th digit indicates the VA (See Model Nomenclature).

(14) Control Relay – (OPT)

The control relay is factory installed in the electrical section. See description of Option 8 for additional details.

(15) Blower Low Voltage Terminal Strip – (STD)

The blower low voltage terminal strip is located in the electrical section. The terminal strip is labeled to match the electrical wiring diagram provided with the unit. Low voltage labeling ranges from terminal numbers 1 to 79. All field wiring connections should be made to the right side of the terminals to prevent miswiring by modifying the factory wiring which is made to the left side of the terminal strip.

16) Dead Front Disconnect Switch – (OPT)

WARNING

Disconnect power supply before making wiring connections or working on this equipment. Follow all applicable safety procedures to prevent accidental power up. Failure to do so can result in injury or death from electrical shock or moving parts and may cause equipment damage.

AVERTISSEMENT

Débranchez l'alimentation électrique avant d'effectuer des connexions ou de travailler sur l'appareil. Respectez toutes les procédures de sécurité qui s'appliquent pour éviter toute mise en marche accidentelle. Le non-respect de cette directive peut entraîner des blessures ou la mort causées par un choc électrique ou des pièces mobiles, en plus d'endommager l'appareil.

The dead front disconnect switch is factory installed in the electrical section. The disconnect switch is designed so that it must be turned "OFF" before entry to the electrical control cabinet can be obtained (See Figure 36.1). When in the "OFF" position, power is disconnected to all unit wiring electrically following the switch (See Warning). For servicing the unit, the disconnect switch can be manually overridden by using a wrench and turning the disconnect switch shaft 90° clockwise (See Figure 36.1).

COMPONENT DESCRIPTIONS

Figure 36.1 - Dead Front Disconnect Switch Assembly

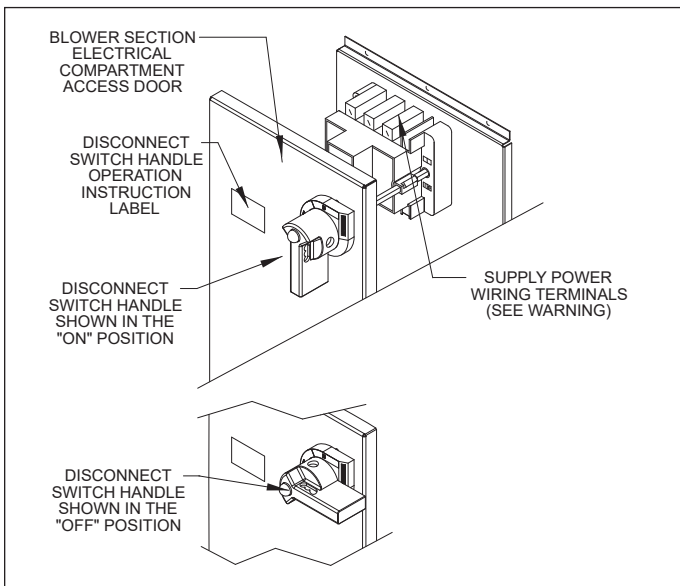

(17) Step Down Transformer Fuses – (OPT)

The transformer fuses are factory installed in the electrical section. The fuses are included to protect the transformer. Fuses included.

(18) Step Down Transformer – (OPT)

The step down transformer is factory installed in the electrical section. The transformer is required for power exhausted units with a supply voltage of 460V/3Ph and 575V/3Ph.

(19) Minimum Positioner – (OPT) (All Except Digit 12=9)

The factory installed minimum positioner is installed in the electrical section and is used with a modulating damper actuator to set the minimum percentage of outside air. The minimum positioner dial is manually set between 0 to 100% resulting in a 2 to 10 VDC signal being sent to the damper actuator.

Figure 36.2 - Minimum Positioner



For units with the Modine Control System option (Model Digit 12=9), this feature is available as a damper control when configured properly and does not require a separate additional positioner. Refer to the latest revision of the Modine Control System Manual, literature 74-510 for additional information.

(22) Return Air Fire Stat – (OPT)

The return air fire stat is factory installed in the electrical section with the sensor in the return air stream. In case of elevated temperatures in the return air stream, the manual reset switch shuts down the entire unit. If the limit temperature is exceeded, a service person must inspect the unit for the cause of the high discharge temperature, take corrective action, and then reset the switch.

(23) Blower Housing – (STD)

The blower housing is factory installed in the blower section. The blower housing contains a double width, double inlet (DWDI) blower wheel so both sides of the blower must be free from obstructions for proper operation. For Right Hand units (Digit 9 = R), during operation the blower wheel should rotate in the clockwise direction when viewed from the service side of the unit. For Left Hand units (Digit 9 = L), during operation the blower wheel should rotate in the counterclockwise direction when viewed from the service side of the unit. If necessary, interchange supply power wiring to reverse blower rotation.

(24) Pillow Block Bearings – (OPT)

The blower bearings are factory installed in the blower section. The blower can be provided with either spider or pillow block bearings. Spider bearings are permanently lubricated and do not require lubrication. Pillow block bearings are shipped non-greased from the factory and require lubrication before start-up. For lubrication recommendations, see Lubrication Recommendations.

(25) Blower Motor – (STD)

The blower motor is factory installed in the blower section. The blower motor can be provided in a variety of supply voltages, frame types, and motor horsepower. Refer to the model nomenclature to determine the type of motor provided. The blower motor is supplied with an adjustable sheave that can be used to increase/decrease the blower RPM. For instructions on changing the blower RPM, refer to Blower Adjustments.

(26) Filters – (OPT)

When filters are supplied with the unit, a rack and the filters are factory installed in the blower section. The unit can be supplied with 2" permanent filters, or 2" pleated throwaway filters in MERV 8 or 13 ratings. For filter replacement, refer to Maintenance.

COMPONENT DESCRIPTIONS

(27) Fresh Air Damper – (OPT)

When a fresh air damper is supplied with the unit, the damper is factory installed in the blower section. The fresh air damper is used as an outside air shut-off damper, so ultra low leak, Class I leakage resistance (less than 4 CFM/ft² at 1" W.C.) dampers with self-compensating stainless steel side seals and santoprene and galvanized steel blade seals are used.

(30) Direct Drive Damper Actuator – (OPT)

The direct drive damper actuator is factory installed in the blower section on the side of the fresh air damper. The actuator controls the position of the fresh air damper. The return air damper, if provided, is controlled by the damper linkage between the two dampers. All damper actuators are low voltage (24V). For Right Hand units (Digit 9 = R), during operation the actuator should rotate in the counterclockwise direction when viewed from the service side of the unit. For Left Hand units (Digit 9 = L), during operation the actuator should rotate in the clockwise direction when viewed from the service side of the unit. Three different types of dampers actuators can be provided: Two-position, Modulating, and Floating.

- **Two-Position Damper Actuator:** A two-position actuator is provided with Air Control options (Model Digits 20-21=DA and EA). The actuator provides open/closed operation of the fresh air damper. When the actuator is energized, the fresh air damper is opened to 100% outside air in 75 seconds (for outside air percentages lower than 100%, refer to the following section, "Setting the Damper Limiter"). Actuators are spring return, so when the damper is de-energized, the fresh air damper will spring closed. Actuators include auxiliary switches (one normally open and one normally closed) that reverse when the damper actuator is at 85° rotation (adjustable).

Setting the Damper Limiter: The two-position damper limiter can be factory set to prevent the outside air damper from opening 100%. Field adjustment of the two-position damper limiter is accomplished by the following:

1. Determine the maximum outside air % required.
2. Locate the angle of rotation limiter on the actuator so that its edge lines up with the degree graduation on the actuator face corresponding to the required rotation. (See Figure 37.1 which is shown at 50% rotation limit.)
3. Position the limiter to the desired position, making sure the locating "teeth" on the limiter are engaged into the locating holes on the actuator.
4. Fasten the limiter to the actuator using the screw provided.
5. Test the damper rotation either manually with the manual crank or apply power. Re-adjust if necessary.
6. If the damper end switch is being used in the control circuit and needs to be adjusted for the new limit position, refer to the next section, "Adjusting the Damper End Switch".

Figure 37.1 - Two-Position Damper Actuator Limiter

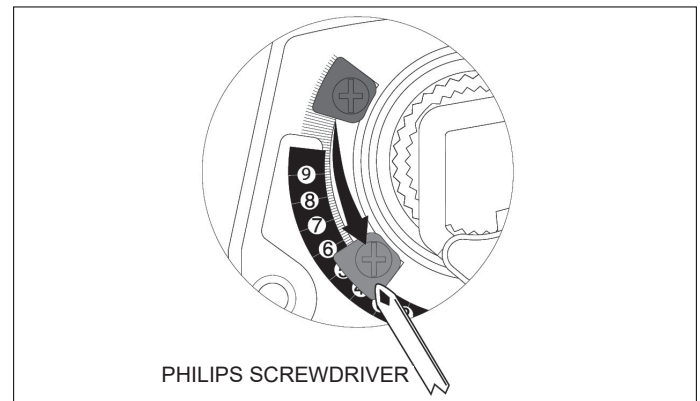

Adjusting the Damper End Switch

If the damper limiter was adjusted in the previous section, it may be required to adjust the Damper End Switch as follows:

1. The actuator must be in its fail-safe position.
2. Insert the crank handle into the torx shaped hole located in the center of the adjustable switch pointer as shown in Figure 37.2.
3. Gently rotate the crank until the switch pointer is at the desired switch point in degrees as shown.

Figure 37.2 - Adjusting the Damper End Switch

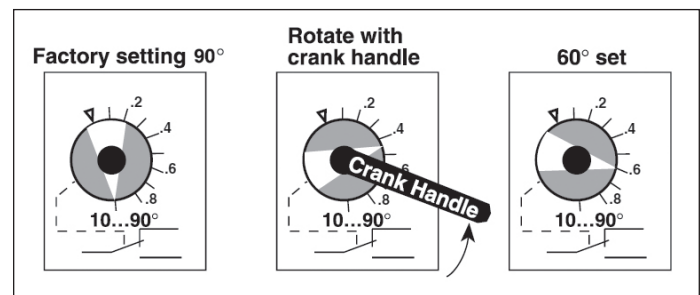

- **Modulating Damper Actuator:** A modulating actuator is provided with Air Control options (Model Digits 20-21=GA, GD, GE, and GH). The actuator provides incremental operation of the fresh air damper (the return air damper is controlled by the fresh air damper position). Full 90° rotation of the actuator requires 150 seconds. Actuators operate using a 0-10 Vdc input signal from a damper controller. Actuators are spring return, so when the damper is de-energized, the fresh air damper will spring closed.

For units with the Modine Control System option (Model Digit 12=9), when the damper control is modulating, Model Digits 20-21 will always be GA and the control will be integral to the Modine Control System control logic. Refer to the latest revision of the Modine Control System Manual, literature 74-510 for additional information.

COMPONENT DESCRIPTIONS

(32) Damper to Damper Linkage – (OPT)

Units with fresh and return air dampers include a damper actuator that controls the fresh air damper. The return air damper position is controlled by the fresh air damper through the connecting rod. For adjustment, refer to Damper Linkage Adjustment.

(33) Return Air Damper – (OPT)

When a return air damper is supplied with the unit, the damper is factory installed in the blower section. The return air damper is used as an air balancing damper so low leak, Class III leakage resistance (less than 40 CFM/ft² at 1" W.C.) dampers with self-compensating stainless steel side seals and santoprene blade seals are used.

(35) Motor and Blower Vibration Isolation – (STD)

The motor vibration isolation is factory installed below the blower support bracket. The four (4) neoprene vibration mount grommet provides isolation of the blower housing and motor from the blower support channels. The blower duct connection is not rigidly mechanically fastened and the 1/4" thick gasketing around the duct transition provides vibration isolation.

Figure 38.1 - Blower/Motor Vibration Isolation

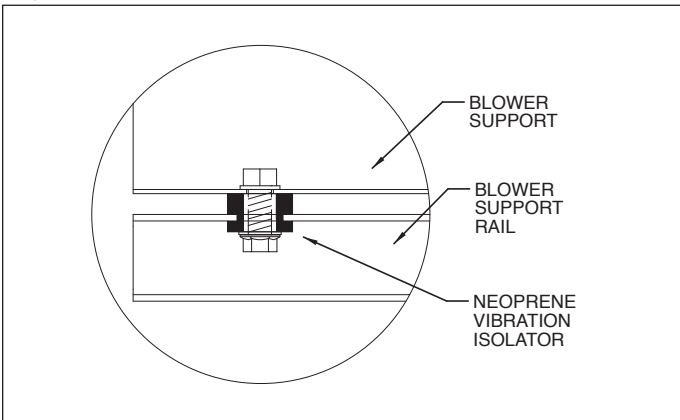

(36) Blower Support – (STD)

The blower supports are factory installed in the blower section. The blower supports are used to rigidly support the weight of the blower and motor during operation and shipping.

(37) Convenience Outlet – (OPT)

⚠ WARNING

Disconnect power supply before making wiring connections or working on this equipment. Follow all applicable safety procedures to prevent accidental power up. Failure to do so can result in injury or death from electrical shock or moving parts and may cause equipment damage.

⚠ AVERTISSEMENT

Débranchez l'alimentation électrique avant d'effectuer des connexions ou de travailler sur l'appareil. Respectez toutes les procédures de sécurité qui s'appliquent pour éviter toute mise en marche accidentelle. Le non-respect de cette directive peut entraîner des blessures ou la mort causées par un choc électrique ou des pièces mobiles, en plus d'endommager l'appareil.

The convenience outlet is factory installed in the blower section for providing power for 115V service equipment (trouble light, power tools, etc.). The 115V ground fault circuit interrupter (GFCI) is rated for 15 amps and includes test and reset switches. A separate field supplied 115V/1Ph power supply must be routed through the electrical section wall into the back of the convenience outlet junction box.

(38) Blower Door Switch – (OPT)

The blower door switch is factory installed inside the blower section door on the access side of the unit. When the blower section door is removed, the momentary switch is released and interrupts power to the low voltage circuit. For single phase units 1-1/2 Hp and less, the door switch de-energizes a relay that controls blower motor operation. For three phase units and single phase units 1-1/2 Hp and greater, the door switch de-energizes the motor starter that controls blower motor operation. For servicing, the switch is equipped with an override position that can be manually pulled out to override the switch. For units with Modine Control System option (Model Digit 12=9), the switch is wired to a digital input on the unit controller.

Figure 38.2 - Blower Door Switch

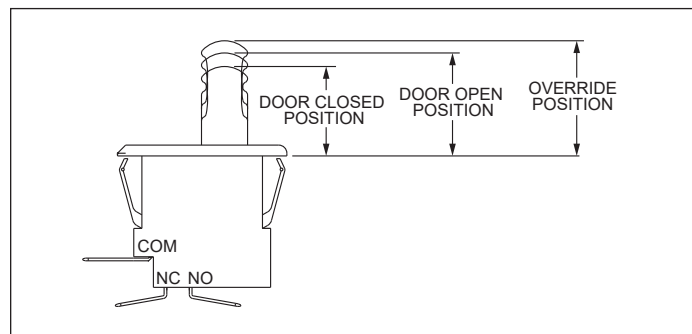

COMPONENT DESCRIPTIONS

(39) Dirty Filter Switch – (OPT)

The dirty filter pressure switch is factory installed in the blower electrical section. The switch monitors the pressure differential between the two sides of the filters. When the filters become dirty, the differential pressure increases and trips the pressure switch which energizes a light on the remote monitoring panel (for units with Modine Control System option (Model Digit 12=9), the switch is wired to a digital input on the unit controller). The switch must be field set with ductwork installed and the blower in operation.

Setting the Dirty Filter Switch

The range of the dirty filter pressure switch is adjustable between 0.17" to 5.0" W.C.

1. Ensure that the unit filters are clean or replace if necessary.
2. Connect the leads of a continuity tester to the NO and C terminals of the dirty filter pressure switch. See Figure 39.1.
3. Turn the set screw of the pressure switch clockwise until it stops. This will set the pressure at 5.0" W.C. and the continuity tester should be sensing an open circuit.
4. Begin turning the screw counterclockwise until the continuity tester senses a closed circuit. This determines the base pressure of the system.
5. Turn the screw clockwise until the continuity tester senses an open circuit and then one additional full turn (This is approximately 0.25" W.C.) This will allow for the increase in static pressure due to dirty filters.

Figure 39.1 - Dirty Filter Pressure Switch and Air Flow Proving Switch

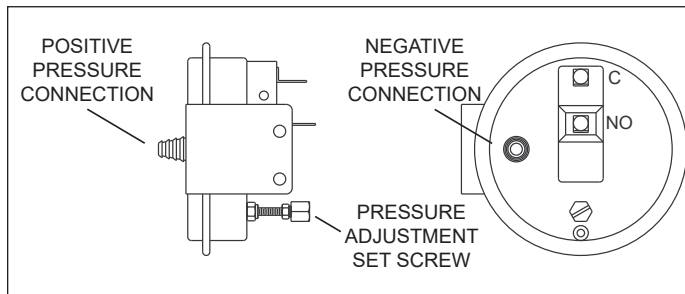

(40) Motor Starter – (OPT)

The motor starter is factory installed in the blower electrical section. A motor starter is required for:

- All three phase motors
- Single phase motors 1-1/2 Hp and greater

If the factory installed motor starter option was not ordered with a unit that requires it, a motor starter must be field supplied and installed. Alternatively for three phase motors, see also the Variable Frequency Drive option below.

The overload module of the motor starter is designed to protect the motor from exceeding the nameplate amps. If the motor exceeds the amp draw on the current set point dial, the trip condition is indicated by a red color in the trip indicator window. The current set point dial is factory set to the motor full load amps listed on the motor nameplate.

The motor starter can be placed in the automatic or manual reset positions. Automatic reset is accomplished by depressing the "RESET" button and turning the button 1/4 turn. When in the automatic reset position, if the overload module trips, the module will reset itself once the overload relay has cooled. In the manual reset position, if the overload module trips, the

"RESET" button must be depressed before the blower can operate.

The contactor module includes one (1) normally open auxiliary contact. The contact rating is 10 amps.

Figure 39.2 - Motor Starter

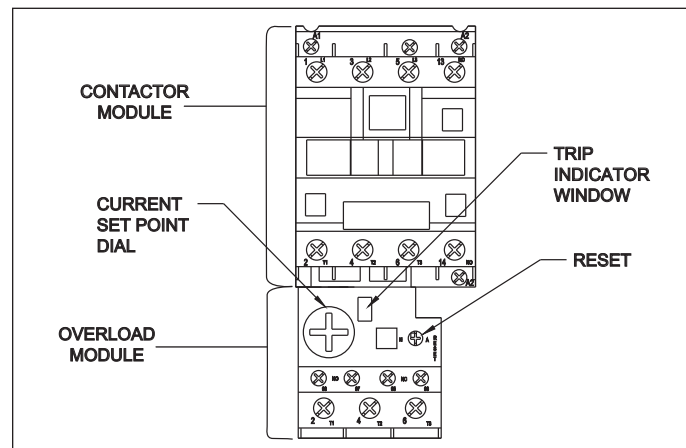

(40) Variable Frequency Drive – (OPT)

The VFD controller adjusts the motor rpm to vary the unit air flow. The minimum air flow may be varied between 30 and 100% of the full speed air flow depending on the controls selection of the unit (refer to the section "Variable Air Volume Applications" on page 32 for additional information).

The control changeover options include two speed, and building management control. For units with the Modine Control System option (Model Digit 12=9), additional control options may be available. Refer to the latest revision of the Modine Control System Manual, literature 74-510 for additional information.

(41) Mild Temperature Stat - (OPT) (All Except Digit 12=9)

The mild temperature thermostat is designed to lockout the burner during mild weather conditions which prevents the burner from cycling. The thermostat must be field set to the desired mild temperature condition. Refer to the latest revision of Modine publication 75-540, "Installation/Setup Instructions, Electronic Mild Temperature Thermostat" for additional instructions.

For units with the Modine Control System option (Model Digit 12=9), this feature is integral to the control logic and utilizes existing sensors included with that option. Refer to the latest revision of the Modine Control System Manual, literature 74-510 for additional information.

COMPONENT DESCRIPTIONS

(43) Warm-Up Stat – (OPT)

A warm-up stat can be provided with Air Control options EA, GG, or GH (Digits 20 & 21) and factory installed in the electrical section with the sensor in the return air stream. The warm-up thermostat monitors the return air temperature to the unit and prevents the fresh air dampers from opening until the temperature of the return air has reached the desired set point (typically 65°F or 5°F below the room temperature).

(44) Blower Supply Power Terminal Strip – (STD)

The terminal strip is labeled to match the electrical wiring diagram provided with the unit. All field wiring connections should be made to the bottom side of the terminals to prevent miswiring by modifying the factory wiring which is made to the top of the terminal strip.

(46) Electronic Modulation Amplifier – (OPT)

An electronic modulation amplifier is provided factory installed in the duct furnace electrical junction box when the unit is equipped with Electronic Modulating Gas Controls (Digit 12=4). The amplifier processes the thermostat temperature and set point signals to modulate the firing rate between 40% to 100% full fire. For additional information, refer to Control Operating Sequence.

(47) Electronic Modulating Gas Valve – (OPT)

An electronic modulating gas valve is provided factory installed in the duct furnace gas train when the unit is equipped with Electronic Modulating Gas Controls (Model Digit 12=4, 7, 8, or 9). The gas valve modulates the firing rate between 40% to 100% full fire based on the input signal from the Electronic Modulation Amplifier (Model Digit 12=4), Signal Conditioner (Model Digit 12=7 or 8), or Modine Control System controller (Model Digit 12=9). For additional information, refer to the Furnace Control Operating Sequence section in this manual.

(48) Air Flow Proving Switch – (OPT) (STD on units with Digit 12=9)

The air flow proving switch is factory installed in the duct furnace electrical junction box. The air flow proving switch monitors the pressure differential between the duct furnace and the atmosphere and disables the the gas controls if a positive pressure is not measured by the switch. This could be caused by a lack of air movement through the heat exchanger.

Note: *The air flow proving switch will prevent any heat exchanger warm-up because the gas controls can not be energized until air flow is proven.*

Setting the Air Flow Proving Switch

The range of the switch is adjustable between 0.17" to 5.0" W.C.

1. Set the thermostat or controller so that there is a call for heat. For units with the Modine Control System option (Model Digit 12=9), refer to the latest revision of the Modine Control System Manual, literature 74-510 for additional information.
2. Turn the set screw of the pressure switch clockwise until it stops. This will set the pressure at 5.0" W.C.
3. Turn the screw counter-clockwise until the gas controls light and then one additional full turn (This is approximately 0.25" W.C.). This will allow for dirty filters or any other slight static pressure increases in the system.

(49) High Limit Switch

The high limit switch is factory installed in the duct furnace electrical junction box. If the limit temperature is exceeded, the gas controls are de-energized.

- **Automatic – (STD):** The automatic reset high limit will reset when the switch is cooled.

(50) Supply Air Fire Stat – (OPT)

The supply air fire stat is factory installed in the duct furnace electrical junction box with the sensor in the discharge air stream. In case of elevated temperatures in the supply air stream, the manual reset switch shuts down the entire unit. If the limit temperature is exceeded, a service person must inspect the unit for the cause of the high discharge temperature, take corrective action, and then reset the switch.

(51) Main Gas Valve – (STD)

The main gas valve is factory installed in the duct furnace gas train. The main gas valve provides the pilot, regulator, main gas, and manual shutoff functions. For additional information, see the supplier literature included with the unit.

(52) Burner Box – (STD)

The burner box is located in the duct furnace section and contains the burner and pilot assembly. The burner box includes an access panel for removal of the burner for inspection and servicing.

COMPONENT DESCRIPTIONS

For Modine Control System Units Only (Model Digit 12=9)

The following items may be included with units configured with the Modine Control System option:

(56) Carel pCOOEM+ Microprocessor Controller

The Modine Controls System utilizes a Carel pCOOEM+ programmable microprocessor controller that is factory installed in the duct furnace electrical section.

(57) Carel pLDPro User Interface Panel

The interface allows a user to access the Carel controller for setpoint changes and to view the operational status of the equipment. The interface features an LED backlit graphic display and buttons for excellent visibility.

(58) Control Relays - (OPT)

The control relay(s) are factory installed in the duct furnace electrical junction box. The relay has a 24V coil with double-pole, double throw (DPDT) contacts. Refer to the unit wiring diagram for the switching function of the relay. The two normally open and two normally closed contacts are rated for a maximum of 8A @ 230V/1Ph.

(59) Unit Enable Relay and/or Cooling Interlock - (OPT)

The control relay is factory installed in the duct furnace electrical junction box and is used to enable the unit based on contact closure from a customer enable circuit. The closing of that contact will power a 24V relay from the unit mounted controller and enable the unit in On or Occupied mode. The relay provides electrical isolation to the controller for protection.

(60) Wiring Channels with Cover - (STD)

The wiring channels organize and separate high voltage and low voltage wiring.

(61) Return Air Sensor (not shown) - (OPT)

This sensor is required on all units that have a mixture of outside and return air. The sensor is field mounted in the return air ductwork. It may be dry bulb only or enthalpy (temperature and humidity).

(62) Outside Air Sensor (not shown) - (OPT)

This sensor is required on all units except 100% return air units and is field installed. Depending on the unit configuration, the sensor may be duct mounted or remote mounted. It may be dry bulb only or enthalpy (temperature and humidity).

(63) Mixed Air Sensor (not shown) - (OPT)

This sensor is required on all units that have a mixture of outside and return air and is factory mounted in the blower cabinet. The sensor is dry bulb temperature only.

(64) Carel pGD1 Digital Display/Interface Module (not shown) - (OPT)

The interface allows a user to access the Carel controller remotely for setpoint changes and to view the operational status of the equipment. The interface features an LED backlit graphic display and buttons for excellent visibility. Also included is a buzzer to indicate alarm conditions. The interface can be used as a handheld device or can be wall mounted. Maintenance personnel may wish to have the pGD1 mounted in an equipment control room.

Refer to the latest revision of the Modine Control System Manual, literature 74-510 for additional information.

GENERAL PERFORMANCE DATA

Table 42.1 - General Performance Data

Model Size (Digits 4-6)	Btu/Hr Input ①	Btu/Hr Output ①	Blower Style/Size		Minimum CFM ②	Maximum CFM	Temperature Rise (°F)	
			(Digit 16)	Size			Maximum	Minimum
100	100,000	81,000	C or D	9-9	750	3000	100	25
			E or F	12-12	1500	3750	50	20
125	125,000	101,250	C or D	9-9	937	3000	100	31
			E or F	12-12	1500	4688	63	20
150	150,000	121,500	C or D	9-9	1125	3000	100	38
			E or F	12-12	1250	5550	90	20
175	175,000	141,750	C or D	9-9	1312	3000	100	44
			E or F	12-12	1312	5550	100	24
200	200,000	162,000	C or D	9-9	1500	3000	100	50
			E or F	12-12	1750	5000	86	30
			G or H	15-15	1750	6500	86	23
225	225,000	182,250	C or D	9-9	1687	3000	100	56
			E or F	12-12	1750	5000	96	34
			G or H	15-15	1750	6500	96	26
250	250,000	202,500	E or F	12-12	1875	5500	100	34
			G or H	15-15	1875	6500	100	29
			I, J, or K	18-18	3000	9375	63	20
300	300,000	243,000	E or F	12-12	2250	5500	100	41
			G or H	15-15	2250	6500	100	35
			I, J, or K	18-18	3000	11250	75	20
350	350,000	283,500	E or F	12-12	2625	5500	100	48
			G or H	15-15	2625	6500	100	40
			I, J, or K	18-18	4000	12000	66	22
400	400,000	324,000	E or F	12-12	3000	5500	100	55
			G or H	15-15	3000	6500	100	46
			I, J, or K	18-18	4000	12000	75	25
500	500,000	405,000	G or H	15-15	3125	6500	120	58
			I, J, or K	18-18	4000	9375	94	40
			L	20-18	4000	9375	94	40
600	600,000	486,000	G or H	15-15	3750	6500	120	69
			I, J, or K	18-18	4000	11250	113	40
			L	20-18	5000	11250	90	40
700	700,000	567,000	G or H	15-15	4375	6500	120	81
			I, J, or K	18-18	4375	13000	120	40
			L	20-18	4375	13000	120	40
800	800,000	648,000	G or H	15-15	5000	6500	120	92
			I, J, or K	18-18	5000	13000	120	46
			L	20-18	5000	14500	120	41
840	1,050,000	850,500	I, J, or K	18-18	6562	13000	120	61
			L	20-18	6562	13000	120	61
960	1,200,000	972,000	I, J, or K	18-18	7500	13000	120	69
			L	20-18	7500	14500	120	62

① Ratings are shown for elevations up to 2,000 feet. For higher elevations, refer to section "Considerations for Elevation" on page 20.

② For Variable Air Volume Applications, see page 32.

GENERAL PERFORMANCE DATA

Table 43.1 - Air Temperature Rise ① ② ③

Model Size	Btu/Hr Input ①	Btu/Hr Output j	Air Temperature Rise Through Unit (°F)									
			20	40	50	60	70	80	90	100	110	120
100	100,000	81,000	3,750	1,875	1,500	1,250	1,071	938	833	750	-	-
125	125,000	101,250	4,688	2,344	1,875	1,563	1,339	1,172	1,042	937	-	-
150	150,000	121,500	5,500	2,813	2,250	1,875	1,607	1,406	1,250	1,125	-	-
175	175,000	141,750	5,500	3,281	2,625	2,188	1,875	1,641	1,458	1,312	-	-
200	200,000	162,000	6,500	3,750	3,000	2,500	2,143	1,875	1,667	1,500	-	-
225	225,000	182,250	6,500	4,219	3,375	2,813	2,411	2,109	1,875	1,687	-	-
250	250,000	202,500	9,375	4,688	3,750	3,125	2,679	2,344	2,083	1,875	-	-
300	300,000	243,000	11,250	5,625	4,500	3,750	3,214	2,813	2,500	2,250	-	-
350	350,000	283,500	12,000	6,563	5,250	4,375	3,750	3,281	2,917	2,625	-	-
400	400,000	324,000	12,000	7,500	6,000	5,000	4,286	3,750	3,333	3,000	-	-
500	500,000	405,000	-	9,375	7,500	6,250	5,357	4,688	4,167	3,750	3,409	3,125
600	600,000	486,000	-	11,250	9,000	7,500	6,429	5,625	5,000	4,500	4,091	3,750
700	700,000	567,000	-	13,000	10,500	8,750	7,500	6,563	5,833	5,250	4,773	4,375
800	800,000	648,000	-	14,500	12,000	10,000	8,571	7,500	6,667	6,000	5,455	5,000
840	1,050,000	850,500	-	-	-	13,000	11,250	9,844	8,750	7,875	7,159	6,562
960	1,200,000	972,000	-	-	-	14,500	12,857	11,250	10,000	9,000	8,182	7,500

① Ratings are shown for elevations up to 2000 feet. For higher elevations, refer to section "Considerations for Elevation" on page 20

② Minimum Air Temperature Rise, Maximum Air Temperature Rise, and Maximum Discharge Air Temperature are as follows:

-For Model Sizes 100-400, Min Air Temp Rise is 20°F, Max Air Temp Rise is 100°F, and Max Discharge Air Temp is 150°F.

-For Model Sizes 500-800, Min Air Temp Rise is 40°F, Max Air Temp Rise is 120°F, and Max Discharge Air Temp is 150°F.

-For Model Sizes 840-960, Min Air Temp Rise is 60°F, Max Air Temp Rise is 120°F, and Max Discharge Air Temp is 150°F.

-Note that these are typical limits but may vary by Model Size. Refer to Table 42.1 for actual limits.

③ For Variable Air Volume Applications, see page 32..

Air Temperature Limits

The maximum allowable discharge air temperature is 150°F. The maximum allowable air temperature rise per furnace for Low Air Temperature Rise Units is 60°F. All system units are designed for a maximum allowable total static pressure of 3.0" W.C.

OPTION & ACCESSORY PRESSURE DROP DATA

Table 44.1 - Option & Accessory Pressure Drop Tables (in "W.C.) ①

Unit Size	Digit 16	CFM	All Units				Weatherproof Unit Only								
			1" Permanent Filters	2" Permanent Filters	2" Farr Aeropleat Filters	2" Farr 30/30 Filters	Evap Cooler 6" Media	Evap Cooler 6" Media w/Prefilter	Evap Cooler 12" Media	Evap Cooler 12" Media w/Prefilter	Downturn Plenum	Rainhood and Birdscreen	Discharge Damper		
100/125	C,D,E,F	741	0.01	0.02	0.02	0.02	0.01	0.06	0.02	0.08	0.00	0.03	0.01		
		1000	0.02	0.02	0.03	0.04	0.02	0.08	0.04	0.12	0.01	0.05	0.01		
		1500	0.03	0.04	0.05	0.07	0.04	0.14	0.08	0.23	0.02	0.07	0.02		
		2000	0.05	0.06	0.07	0.10	0.08	0.21	0.15	0.36	0.04	0.10	0.03		
		2500	0.07	0.08	0.10	0.14	0.12	0.30	0.23	0.53	0.07	0.13	0.04		
		3000	0.09	0.11	0.13	0.19	0.17	0.40	0.34	0.73	0.11	0.16	0.05		
		3500	0.11	0.13	0.16	0.24	0.23	0.51	0.46	0.97	0.15	0.19	0.07		
		4000	0.14	0.16	0.20	0.30	0.30	0.63	0.60	1.23	0.19	0.22	0.09		
		4500	0.17	0.20	0.25	0.37	4000 Max CFM Evap						0.25	0.25	0.11
		4630	0.17	0.21	0.26	0.39							0.26	0.26	0.11
150/175	C,D,E,F	1111	0.01	0.02	0.03	0.04	0.01	0.07	0.03	0.09	0.02	0.02	0.01		
		1500	0.02	0.03	0.04	0.05	0.03	0.10	0.05	0.15	0.02	0.03	0.01		
		2000	0.03	0.04	0.06	0.08	0.04	0.15	0.09	0.24	0.04	0.05	0.02		
		2500	0.05	0.06	0.09	0.11	0.07	0.20	0.14	0.34	0.05	0.08	0.02		
		3000	0.06	0.08	0.11	0.15	0.10	0.27	0.20	0.46	0.07	0.10	0.04		
		3500	0.08	0.11	0.14	0.18	0.14	0.34	0.27	0.61	0.10	0.14	0.05		
		4000	0.11	0.13	0.18	0.23	0.18	0.41	0.35	0.77	0.13	0.18	0.06		
		4500	0.13	0.16	0.21	0.27	0.23	0.50	0.45	0.95	0.17	0.22	0.08		
		5000	0.16	0.19	0.25	0.32	0.28	0.59	0.55	1.15	0.21	0.27	0.10		
		5200	0.17	0.21	0.27	0.34	0.30	0.63	0.60	1.23	0.23	0.29	0.11		
5556	0.19	0.23	0.30	0.38	5200 Max CFM for Evap						0.26	0.33	0.13		
200/225	C,D,E,F,G,H	1481	0.01	0.02	0.03	0.03	0.02	0.08	0.04	0.12	0.02	0.03	0.01		
		2000	0.01	0.02	0.04	0.04	0.03	0.12	0.07	0.19	0.03	0.05	0.01		
		2500	0.02	0.04	0.05	0.06	0.05	0.17	0.10	0.27	0.04	0.08	0.02		
		3000	0.03	0.05	0.07	0.08	0.08	0.22	0.15	0.36	0.06	0.10	0.04		
		3500	0.03	0.06	0.09	0.10	0.10	0.27	0.20	0.47	0.09	0.14	0.05		
		4000	0.05	0.08	0.11	0.12	0.13	0.33	0.27	0.60	0.11	0.18	0.06		
		4500	0.06	0.10	0.13	0.15	0.17	0.40	0.34	0.73	0.14	0.22	0.08		
		5000	0.07	0.11	0.16	0.18	0.21	0.47	0.42	0.89	0.18	0.27	0.10		
		5500	0.09	0.14	0.19	0.21	0.25	0.55	0.50	1.05	0.21	0.32	0.12		
		6000	0.11	0.16	0.22	0.25	0.30	0.63	0.60	1.23	0.26	0.38	0.14		
6500	0.13	0.18	0.25	0.28	6000 Max CFM for Evap						0.30	0.45	0.16		
250/300	E,F,G,H	1852	0.03	0.02	0.05	0.05	0.02	0.10	0.05	0.15	0.02	0.07	0.02		
		2000	0.03	0.03	0.05	0.06	0.03	0.11	0.06	0.17	0.02	0.08	0.02		
		2500	0.04	0.04	0.07	0.09	0.04	0.15	0.09	0.24	0.03	0.09	0.03		
		3000	0.05	0.06	0.10	0.11	0.06	0.19	0.13	0.32	0.04	0.12	0.04		
		3500	0.07	0.08	0.12	0.15	0.09	0.24	0.17	0.41	0.06	0.14	0.06		
		4000	0.08	0.10	0.15	0.18	0.11	0.29	0.23	0.52	0.08	0.16	0.07		
		4500	0.10	0.13	0.18	0.22	0.15	0.35	0.29	0.64	0.10	0.19	0.09		
		5500	0.14	0.19	0.25	0.31	0.22	0.48	0.43	0.91	0.15	0.25	0.13		
		6500	0.19	0.26	0.34	0.42	0.30	0.63	0.60	1.23	0.21	0.31	0.18		
		7250	0.23	0.32	0.41	0.51	6500 Max CFM for Evap						0.27	0.37	0.23
350/400	E,F,G,H	1925	0.02	0.01	0.03	0.03	0.01	0.05	0.02	0.08	0.02	0.07	0.02		
		3000	0.03	0.03	0.05	0.05	0.03	0.10	0.05	0.15	0.04	0.12	0.04		
		4000	0.05	0.05	0.08	0.09	0.04	0.15	0.09	0.23	0.08	0.16	0.07		
		5000	0.08	0.08	0.11	0.12	0.07	0.20	0.14	0.34	0.12	0.22	0.11		
		6000	0.11	0.11	0.15	0.16	0.10	0.26	0.20	0.46	0.18	0.28	0.16		
		7000	0.15	0.15	0.19	0.21	0.14	0.34	0.27	0.61	0.25	0.35	0.21		
		8000	0.19	0.20	0.24	0.27	0.18	0.41	0.35	0.77	0.33	0.42	0.28		
		9000	0.24	0.25	0.30	0.33	0.23	0.50	0.45	0.95	0.42	0.51	0.35		
		10400	0.32	0.33	0.38	0.42	0.30	0.64	0.60	1.23	0.57	0.64	0.47		
		11111	0.36	0.38	0.43	0.47	10400 Max CFM for Evap						0.66	0.71	0.53
700/800	E,F,G,H	2593	0.02	0.02	0.04	0.04	0.03	0.10	0.05	0.16	0.02	0.03	0.01		
		3000	0.02	0.02	0.05	0.05	0.04	0.13	0.07	0.20	0.03	0.04	0.01		
		3500	0.03	0.03	0.06	0.06	0.05	0.16	0.10	0.25	0.04	0.05	0.01		
		4000	0.03	0.04	0.07	0.08	0.06	0.19	0.13	0.32	0.05	0.07	0.01		
		4500	0.04	0.05	0.09	0.10	0.08	0.23	0.16	0.39	0.06	0.09	0.02		
		5000	0.05	0.06	0.10	0.12	0.10	0.27	0.20	0.47	0.07	0.11	0.02		
		5500	0.06	0.07	0.12	0.14	0.12	0.31	0.24	0.55	0.09	0.14	0.03		
		6000	0.06	0.08	0.14	0.17	0.15	0.36	0.29	0.64	0.10	0.17	0.04		
		6500	0.07	0.10	0.16	0.19	0.17	0.40	0.34	0.74	0.12	0.20	0.04		
		7000	0.08	0.11	0.18	0.22	0.20	0.45	0.39	0.85	0.14	0.23	0.05		
840/960	I,J,K,L	2593	0.02	0.01	0.02	0.02	0.02	0.08	0.03	0.11	0.02	0.03	0.01		
		3000	0.02	0.02	0.02	0.03	0.02	0.09	0.04	0.14	0.03	0.04	0.01		
		4000	0.03	0.03	0.04	0.04	0.04	0.14	0.08	0.22	0.05	0.07	0.01		
		5000	0.04	0.04	0.05	0.06	0.06	0.19	0.12	0.31	0.07	0.11	0.02		
		6000	0.06	0.05	0.07	0.08	0.09	0.25	0.18	0.42	0.10	0.17	0.04		
		7000	0.07	0.07	0.10	0.11	0.12	0.31	0.24	0.55	0.14	0.23	0.05		
		8000	0.09	0.09	0.12	0.13	0.16	0.38	0.32	0.70	0.19	0.30	0.08		
		9000	0.11	0.12	0.15	0.16	0.20	0.46	0.40	0.86	0.24	0.38	0.10		
		10000	0.13	0.14	0.18	0.19	0.25	0.54	0.50	1.04	0.30	0.48	0.14		
		11050	0.15	0.17	0.22	0.23	0.31	0.64	0.61	1.24	0.36	0.58	0.17		
12000	0.18	0.20	0.26	0.27	11050 Max CFM for Evap						0.43	0.69	0.21		
13000	0.20	0.24	0.30	0.31							0.51	0.81	0.26		

① Accessory / Option static pressure losses are approximate values only. Please consult the Accuspec selection software for static pressure losses at other than listed CFM.

BLOWER PERFORMANCE DATA

Table 45.1 - Unit Performance Tables ① ②

Unit Size	Digit 16	Air Temp. Rise	CFM	Total Static Pressure, "W.C.																	
				0.25		0.50		0.75		1.00		1.25		1.50		2.00		2.50		3.00	
				BHP	RPM	BHP	RPM	BHP	RPM	BHP	RPM	BHP	RPM	BHP	RPM	BHP	RPM	BHP	RPM	BHP	RPM
100/125 Start 125	C,D	100°F / -	741	-	-	0.15	808	0.23	962	0.30	1093	0.38	1212	0.47	1320	0.60	1514	0.86	1686	1.07	1840
		80°F/100°F	926	0.13	670	0.21	846	0.29	993	0.38	1121	0.47	1236	0.56	1342	0.77	1532	0.99	1702	1.22	1856
		62°F/77°F	1200	0.22	758	0.31	916	0.41	1052	0.52	1173	0.62	1282	0.74	1384	0.97	1568	1.22	1733	1.48	1884
		53°F/66°F	1400	0.30	828	0.41	975	0.53	1103	0.64	1218	0.76	1323	0.89	1422	1.15	1600	1.42	1762	1.70	1910
		41°F/51°F	1800	0.55	982	0.69	1108	0.83	1220	0.98	1325	1.12	1422	1.27	1513	1.58	1681	1.90	1834	2.23	1976
		34°F/42°F	2200	0.93	1145	1.10	1254	1.27	1354	1.44	1449	1.61	1537	1.79	1621	2.15	1778	2.52	1923	2.90	2057
		28°F/36°F	2600	1.45	1315	1.65	1410	1.85	1500	2.05	1585	2.25	1666	2.46	1744	3.35	1638	-	-	-	-
		25°F/31°F	3000	2.16	1489	2.39	1573	2.61	1654	2.84	1731	-	-	-	-	-	-	-	-	-	-
100/125 End 100	E,F	41°F/51°F	1800	0.28	497	0.41	622	0.56	735	0.72	837	-	-	-	-	-	-	-	-	-	-
		34°F/42°F	2200	0.43	553	0.58	662	0.75	762	0.93	855	1.12	942	1.33	1025	-	-	-	-	-	-
		28°F/36°F	2600	0.63	614	0.81	710	1.00	800	1.20	885	1.41	965	1.63	1042	-	-	-	-	-	-
		25°F/31°F	3000	0.91	680	1.11	766	1.32	847	1.54	927	1.77	997	2.01	1068	2.51	1202	3.04	1328	3.60	1446
		22°F/27°F	3400	1.26	748	1.48	825	1.72	899	1.96	970	2.21	1038	2.47	1104	3.01	1229	3.58	1347	4.17	1459
		20°F/25°F	3704	1.58	802	1.83	873	2.08	942	2.34	1008	2.60	1072	2.88	1135	3.45	1254	4.04	1367	4.67	1474
		- / 23°F	4100	2.09	873	2.35	938	2.63	1001	2.91	1062	3.20	1122	3.49	1180	4.10	1291	4.74	1398	-	-
		- / 20°F	4630	2.93	969	3.23	1028	3.53	1085	3.84	1140	4.16	1194	4.48	1247	-	-	-	-	-	-
150/175 Start 175	C,D	100°F/117°F	1111	0.19	727	0.28	884	0.38	1023	0.48	1148	0.59	1262	0.70	1369	0.94	1563	1.21	1738	1.48	1899
		86°F/100°F	1296	0.27	793	0.37	937	0.47	1066	0.59	1184	0.71	1293	0.83	1395	1.09	1582	1.37	1752	1.66	1909
		79°F/93°F	1400	0.32	832	0.42	970	0.54	1093	0.66	1208	0.78	1313	0.91	1412	1.18	1596	1.47	1763	1.78	1917
		62°F/72°F	1800	0.59	994	0.72	1109	0.86	1216	1.00	1316	1.15	1410	1.30	1500	1.62	1667	1.95	1823	2.29	1967
		51°F/59°F	2200	1.00	1166	1.16	1264	1.32	1356	1.49	1444	1.66	1529	1.84	1610	2.20	1762	2.57	1906	2.96	2041
		43°F/50°F	2600	1.58	1344	1.76	1429	1.95	1510	2.14	1589	2.34	1664	2.54	1737	2.95	1877	-	-	-	-
		37°F/43°F	3000	2.35	1526	2.57	1600	2.78	1673	3.00	1743	-	-	-	-	-	-	-	-	-	-
		34°F/40°F	3400	3.30	1724	3.57	1798	3.84	1872	4.11	1946	-	-	-	-	-	-	-	-	-	-
150/175	E,F	86°F/100°F	1296	-	-	0.25	609	0.37	734	-	-	-	-	-	-	-	-	-	-	-	
		79°F/93°F	1400	0.17	474	0.28	615	0.40	737	-	-	-	-	-	-	-	-	-	-	-	
		62°F/72°F	1800	0.28	526	0.41	650	0.55	760	0.70	859	0.85	952	-	-	-	-	-	-	-	
		51°F/59°F	2200	0.44	588	0.59	697	0.75	796	0.91	887	1.09	972	1.27	1052	1.67	1201	-	-	-	-
		43°F/50°F	2600	0.67	657	0.83	753	1.01	842	1.19	925	1.39	1004	1.59	1078	2.02	1218	2.47	1348	2.96	1469
		37°F/43°F	3000	0.96	729	1.15	815	1.35	895	1.55	972	1.76	1044	1.98	1114	2.45	1245	2.94	1368	3.45	1483
		33°F/38°F	3400	1.35	804	1.55	881	1.77	955	2.00	1025	2.23	1092	2.47	1157	2.96	1280	3.49	1396	4.03	1505
		29°F/34°F	3800	1.82	880	2.05	951	2.29	1018	2.53	1083	2.79	1146	3.04	1206	3.58	1322	4.14	1431	4.72	1535
200/225 Start 225	C,D	100°F/113°F	1481	0.36	871	0.48	1016	0.60	1144	0.73	1259	0.85	1366	0.99	1465	1.26	1646	1.54	1808	1.84	1958
		89°F/100°F	1667	0.48	943	0.61	1078	0.75	1198	0.88	1309	1.03	1411	1.17	1507	1.47	1682	1.77	1842	2.09	1988
		85°F/95°F	1750	0.54	975	0.68	1106	0.82	1224	0.96	1332	1.11	1433	1.26	1527	1.57	1700	1.88	1857	2.21	2003
		74°F/83°F	2000	0.76	1077	0.92	1197	1.08	1306	1.24	1407	1.40	1502	1.57	1592	1.91	1758	2.26	1910	2.62	2051
		66°F/74°F	2250	1.04	1181	1.21	1291	1.39	1393	1.57	1488	1.75	1577	1.94	1663	2.31	1822	2.69	1969	-	-
		59°F/67°F	2500	1.38	1288	1.57	1389	1.77	1484	1.97	1573	2.17	1658	2.37	1739	2.78	1892	-	-	-	-
		54°F/61°F	2750	1.79	1396	2.00	1490	2.22	1579	2.44	1663	2.66	1743	2.88	1820	-	-	-	-	-	-
		49°F/56°F	3000	2.28	1506	2.51	1593	2.75	1677	2.98	1756	-	-	-	-	-	-	-	-	-	-
200/225	E,F	85°F/95°F	1750	0.29	594	0.43	723	0.58	838	0.75	944	0.94	1042	1.14	1134	1.58	1303	2.07	1458	2.60	1600
		74°F/83°F	2000	0.40	642	0.54	759	0.71	866	0.88	966	1.08	1058	1.28	1146	1.74	1309	2.23	1458	2.78	1595
		59°F/67°F	2500	0.68	746	0.85	845	1.04	938	1.23	1025	1.45	1108	1.67	1188	2.15	1337	2.67	1475	3.24	1604
		49°F/56°F	3000	1.09	857	1.29	942	1.50	1024	1.72	1101	1.95	1176	2.19	1248	2.71	1384	3.27	1511	3.86	1632
		42°F/48°F	3500	1.66	972	1.88	1047	2.12	1119	2.36	1188	2.61	1255	2.88	1320	3.43	1455	4.03	1563	-	-
		37°F/42°F	4000	2.40	1091	2.65	1157	2.91	1221	3.18	1284	3.46	1345	3.75	1404	4.35	1518	4.98	1628	-	-
		33°F/37°F	4500	3.34	1211	3.62	1270	3.91	1329	4.21	1385	4.51	1441	4.82	1495	-	-	-	-	-	-
		30°F/33°F	5000	4.52	1332	4.82	1387	-	-	-	-	-	-	-	-	-	-	-	-	-	-
200/225	G,H	85°F/95°F	1750	0.20	425	0.33	546	0.48	653	-	-	-	-	-	-	-	-	-	-	-	
		74°F/83°F	2000	0.26	449	0.40	562	0.56	662	0.74	754	-	-	-	-	-	-	-	-	-	
		59°F/67°F	2500	0.42	507	0.58	603	0.75	692	0.94	774	1.16	851	1.38	925	-	-	-	-	-	
		49°F/56°F	3000	0.65	571	0.83	654	1.02	732	1.23	807	1.45	877	1.69	944	2.21	1071	-	-	-	
		42°F/48°F	3500	0.97	639	1.17	713	1.38	782	1.60	850	1.84	914	2.10	975	2.64	1093	3.23	1202	3.86	1307
		37°F/42°F	4000	1.38	710	1.60	776	1.83	839	2.08	899	2.34	958	2.60	1014	3.18	1123	3.80	1226	4.46	1324
		33°F/37°F	4500	1.90	783	2.14	842	2.40	899	2.66	955	2.94	1008	3.23	1061	3.84	1161	4.48	1258	-	-
		30°F/33°F	5000	2.54	858	2.81	911	3.08	963	3.37	1014	3.67	1064	3.98	1112	4.62	1206	-	-	-	-
200/225	G,H	27°F/30°F	5500	3.32	933	3.61	982	3.91	1030	4.22	1077	4.54	1123	4.87	1168	-	-	-	-	-	
		25°F/28°F	6000	4.25	1009	4.57	1054	4.89	1099	-	-	-	-	-	-	-	-	-	-	-	

① Total static pressure should include external static pressure and accessory / option static pressure from Table 44.1. Unit internal resistance has been included in the unit performance tables.

② Brake Horsepower and RPM values are approximate values only. Please consult the AccuSpec selection software for values at other than listed CFM / static pressures.

BLOWER PERFORMANCE DATA

Table 46.1 - Unit Performance Tables ①②

Unit Size	Digit 16	Air Temp. Rise	CFM	Total Static Pressure, "W.C.																	
				0.25		0.50		0.75		1.00		1.25		1.50		2.00		2.50		3.00	
				BHP	RPM	BHP	RPM	BHP	RPM	BHP	RPM	BHP	RPM	BHP	RPM	BHP	RPM	BHP	RPM	BHP	RPM
250/300 Start 300	E,F	100°F / 120°F	1852	0.26	532	0.39	665	0.54	782	0.69	887	0.85	985	1.03	1074	1.39	1239	1.79	1387	2.21	1523
		83°F / 100°F	2222	0.39	582	0.54	703	0.70	810	0.87	909	1.05	1000	1.24	1085	1.64	1242	2.06	1385	2.52	1517
		74°F / 89°F	2500	0.51	625	0.68	736	0.85	836	1.04	930	1.23	1016	1.43	1099	1.85	1250	2.30	1389	2.78	1517
		62°F / 74°F	3000	0.80	706	0.99	803	1.19	893	1.40	978	1.62	1058	1.84	1133	2.31	1275	2.81	1406	3.33	1529
		53°F / 63°F	3500	1.19	793	1.41	878	1.64	959	1.87	1036	2.12	1109	2.36	1179	2.88	1312	3.42	1435	3.99	1552
		46°F / 56°F	4000	1.69	882	1.94	958	2.20	1032	2.46	1102	2.73	1170	3.01	1234	3.58	1358	4.17	1474	4.78	1584
		41°F / 49°F	4500	2.34	974	2.62	1043	2.90	1109	3.19	1174	3.49	1236	3.79	1296	4.41	1412	-	-	-	-
		37°F / 44°F	5000	3.14	1067	3.44	1130	3.76	1191	4.08	1250	4.40	1308	4.73	1364	-	-	-	-	-	-
		34°F / 40°F	5500	4.11	1161	4.44	1219	4.78	1275	-	-	-	-	-	-	-	-	-	-	-	-
		250/300 Start 300	G,H	100°F / 120°F	1852	-	-	0.34	519	0.49	623	0.66	713	0.85	795	1.05	870	1.47	1005	1.94	1126
83°F / 100°F	2222			0.28	424	0.43	537	0.61	634	0.79	721	0.99	800	1.20	872	1.65	1005	2.14	1123	2.67	1231
74°F / 89°F	2500			0.35	447	0.52	553	0.71	646	0.90	730	1.11	806	1.33	877	1.81	1006	2.32	1123	2.87	1230
62°F / 74°F	3000			0.53	492	0.72	588	0.93	674	1.15	752	1.38	824	1.62	892	2.13	1016	2.68	1129	3.27	1232
53°F / 63°F	3500			0.76	542	0.98	637	1.21	707	1.45	780	1.71	848	1.97	912	2.52	1031	3.11	1140	3.74	1240
46°F / 56°F	4000			1.07	594	1.31	673	1.57	746	1.83	814	2.11	878	2.39	939	2.99	1052	3.62	1156	4.28	1253
41°F / 49°F	4500			1.45	649	1.72	721	2.00	789	2.29	852	2.59	912	2.90	969	3.54	1077	4.22	1177	4.92	1270
37°F / 44°F	5000			1.92	706	2.22	771	2.52	834	2.84	894	3.16	950	3.50	1004	4.18	1107	4.90	1202	-	-
34°F / 40°F	5500			2.50	767	2.81	824	3.14	882	3.49	938	3.83	991	4.19	1042	4.93	1140	-	-	-	-
31°F / 37°F	6000			3.16	822	3.52	878	3.87	933	4.24	984	4.61	1035	5.00	1084	-	-	-	-	-	-
28°F / 34°F	6500	3.96	881	4.34	934	4.72	984	-	-	-	-	-	-	-	-	-	-	-	-		
250/300 End 250	I, J, K	46°F / 56°F	4000	-	-	0.97	507	1.25	583	1.56	654	1.89	719	2.24	781	-	-	-	-	-	-
		37°F / 44°F	5000	-	-	1.51	560	1.84	626	2.19	688	2.56	748	2.95	804	3.77	908	4.67	1005	-	-
		31°F / 37°F	6000	1.94	559	2.29	620	2.66	679	3.06	734	3.46	787	3.89	838	4.79	935	5.75	1025	6.77	1110
		26°F / 32°F	7000	2.93	632	3.33	686	3.75	738	4.19	788	4.64	836	5.11	882	6.09	971	7.13	1055	8.22	1134
		23°F / 28°F	8000	4.24	707	4.69	755	5.16	802	5.64	847	6.14	891	6.65	933	7.72	1015	8.83	1093	10.00	1167
		20°F / 24°F	9259	6.40	804	6.91	846	7.45	887	7.99	927	8.55	966	9.12	1004	10.30	1079	11.52	1150	12.79	1218
		- / 22°F	10000	7.97	862	8.52	901	9.09	939	9.67	977	10.27	1014	10.87	1050	12.12	1120	13.41	1187	14.74	1252
		- / 20°F	11111	10.79	949	11.40	985	12.03	1020	12.66	1054	13.31	1087	13.97	1121	-	-	-	-	-	-
		100°F / -	2593	0.61	668	0.80	781	1.01	882	1.22	975	1.45	1061	1.69	1142	2.19	1290	2.73	1425	3.30	1550
		96°F / -	2700	0.67	686	0.87	796	1.08	895	1.30	986	1.53	1071	1.78	1151	2.29	1297	2.84	1431	3.42	1555
350/400 Start 400	E,F	87°F / 100°F	2963	0.85	730	1.06	834	1.28	928	1.52	1015	1.76	1097	2.02	1174	2.56	1316	3.13	1446	3.74	1568
		74°F / 85°F	3500	1.30	826	1.54	917	1.80	1002	2.07	1081	2.34	1157	2.62	1228	3.22	1362	3.84	1486	4.50	1602
		65°F / 74°F	4000	1.86	918	2.13	1000	2.42	1078	2.71	1151	3.01	1221	3.32	1288	3.97	1414	4.65	1531	-	-
		58°F / 66°F	4500	2.57	1012	2.87	1087	3.18	1158	3.51	1226	3.84	1291	4.18	1353	4.88	1472	-	-	-	-
		52°F / 59°F	5000	3.44	1109	3.78	1177	4.12	1242	4.47	1305	4.84	1366	-	-	-	-	-	-	-	
		47°F / 54°F	5500	4.50	1206	4.87	1269	-	-	-	-	-	-	-	-	-	-	-	-	-	-
		100°F / -	2593	0.43	479	0.62	585	0.84	679	1.09	764	1.35	841	1.64	1142	2.26	1046	2.94	1165	3.68	1275
		87°F / 100°F	2963	0.57	516	0.79	614	1.02	702	1.28	782	1.56	856	1.86	926	2.50	1053	3.20	1170	3.96	1277
		74°F / 85°F	3500	0.85	574	1.09	662	1.35	742	1.63	815	1.93	885	2.25	951	2.93	1072	3.66	1183	4.45	1287
		65°F / 74°F	4000	1.19	631	1.45	710	1.74	784	2.04	853	2.36	918	2.70	980	3.41	1096	4.19	1202	-	-
58°F / 66°F	4500	1.61	690	1.91	762	2.22	830	2.55	895	2.89	956	3.25	1014	4.00	1124	4.81	1226	-	-		
52°F / 59°F	5000	2.22	767	2.46	817	2.80	880	3.15	940	3.52	998	3.90	1053	4.70	1157	-	-	-	-		
47°F / 54°F	5500	2.77	813	3.12	874	3.49	933	3.87	989	4.25	1042	4.66	1095	-	-	-	-	-	-		
43°F / 49°F	6000	3.53	876	3.91	933	4.30	987	4.70	1040	-	-	-	-	-	-	-	-	-	-		
40°F / 46°F	6500	4.42	939	4.82	992	-	-	-	-	-	-	-	-	-	-	-	-	-	-		
350/400 Start 400	I,J,K	100°F / -	2593	-	-	-	0.77	561	1.04	639	1.34	709	1.66	774	2.36	891	3.14	995	4.00	1090	
		87°F / 100°F	2963	-	-	-	0.89	571	1.18	646	1.49	715	1.81	779	2.54	894	3.34	997	4.20	1091	
		65°F / 74°F	4000	-	-	1.07	533	1.37	609	1.69	679	2.03	742	2.40	802	3.18	910	4.04	1009	4.96	1099
		52°F / 59°F	5000	1.37	515	1.69	590	2.04	658	2.41	721	2.79	779	3.19	835	4.05	937	4.98	1030	5.96	1117
		43°F / 49°F	6000	2.20	588	2.58	654	2.97	715	3.39	772	3.82	826	4.26	877	5.20	973	6.21	1061	7.26	1144
		37°F / 42°F	7000	3.34	665	3.77	723	4.22	778	4.68	830	5.16	879	5.65	927	6.68	1016	7.77	1099	8.90	1178
		32°F / 37°F	8000	4.84	744	5.33	796	5.83	845	6.34	893	6.87	938	7.41	982	8.53	1066	9.70	1144	10.92	1219
		29°F / 33°F	9000	6.75	824	7.29	871	7.85	917	8.41	960	8.99	1002	9.58	1043	10.80	1121	12.07	1194	13.37	1265
		26°F / 30°F	10000	9.13	906	9.72	948	10.33	990	10.95	1030	11.58	1069	12.22	1107	13.54	1180	14.90	1249	-	-
		24°F / 27°F	11000	12.01	988	12.66	1027	13.32	1065	14.00	1103	14.68	1139	-	-	-	-	-	-	-	-
23°F / 26°F	11500	13.66	12.09	14.34	1067	-	-	-	-	-	-	-	-	-	-	-	-	-	-		

① Total static pressure should include external static pressure and accessory / option static pressure from Table 44.1. Unit internal resistance has been included in the unit performance tables.

② Brake Horsepower and RPM values are approximate values only. Please consult the AccuSpec selection software for values at other than listed CFM / static pressures.

BLOWER SHEAVE ASSEMBLY DATA

Adjusting the Blower Drive Sheave Setting

All units include a sheave assembly indicated by Digit 19 of the model nomenclature. Within that assembly are the fixed blower sheave, adjustable motor sheave, and belt(s) to provide a method of adjusting the blower speed to balance the airflow based on actual external static pressure for the installation. The motor sheave is adjusted at the factory for external static conditions indicated on the order detail, however actual external static often varies from design, resulting in a need to adjust the equipment to provide correct design airflow.

To determine how many turns open the motor sheave should be set for:

1. Locate the unit Model Identification Plate and identify the following model number digits:
 - Digits 4-6 = Model Size
 - Digit 16 = Blower Size
 - Digit 19 = Sheave Arrangement
2. Use Table 44.1 to determine the individual static pressure drops for any features included on the unit for the design airflow. Add those and the design external static pressure to calculate the total static pressure.
3. Use Table 45.1 through Table 47.1 to determine the blower speed (RPM) required to meet the job requirements.
4. Use Table 49.1 to determine the RPM range and approximately blower speeds for each 1/2 turn open of the adjustable motor sheave. Find the RPM that is closest to one value shown to determine the turns open and set the motor sheave as described in the section "Blower Adjustments" on page 29

Example:

Determine motor sheave turns open for a unit operating at 4000 CFM with a design external static pressure (ESP) of 0.60"W.C. as follows:

1. From the Model Nomenclature:
 - Model size (Model Digit 4-6) = 400
 - Blower size (Model Digit 16) = E
 - Sheave arrangement (Model Digit 19) = J
2. From Table 44.1, the unit includes 2" Farr 30/30 Filters (0.08"W.C. static) and Rainhood & Birdscreen (0.07"W.C. static). Total static pressure is $0.08+0.07+0.60=0.75$ "W.C.
3. From Table 46.1, the blower speed is 1078 RPM.
4. From Table 49.1, the blower range is 1029-1332 RPM. The closest value to 1078 RPM in the row of Blower RPM by Sheave Turns Open is 1090 RPM, which corresponds to 4.0 turns open.

If actual job ESP after installation was measured at 0.75"W.C., the process above would be repeated with the new TSP of 0.90"W.C.

Figure 48.1 - Blower Section

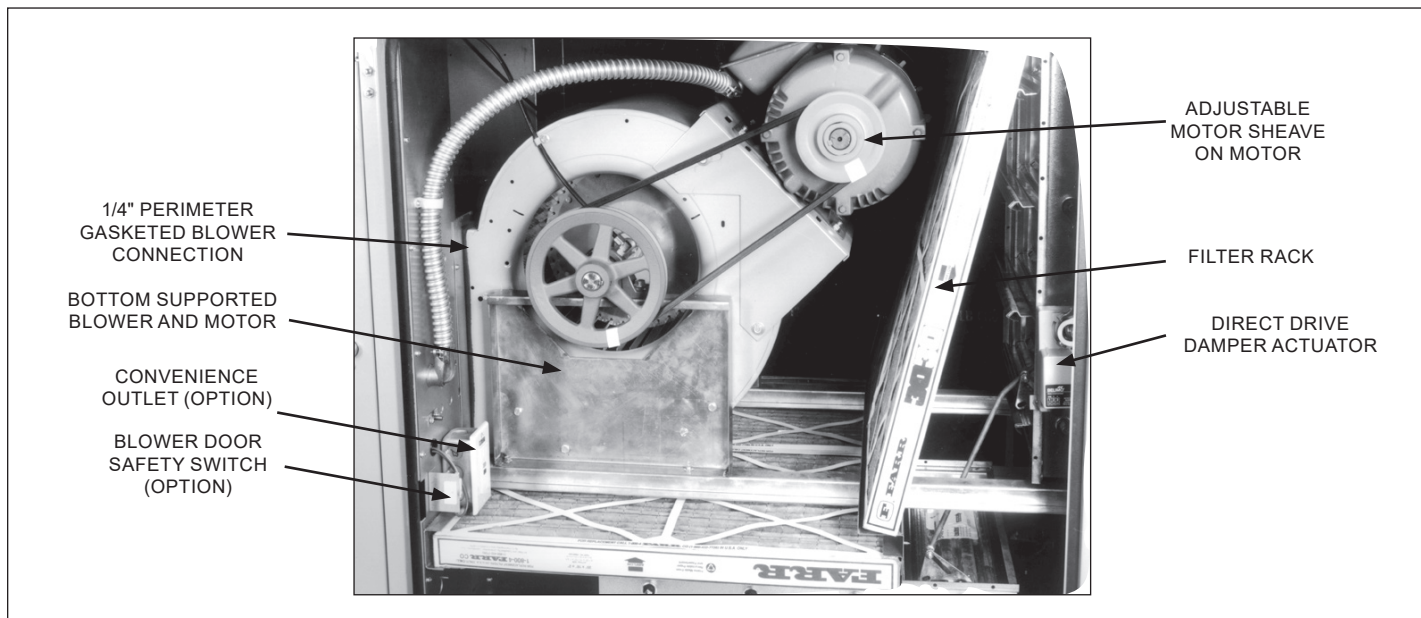

BLOWER SHEAVE ASSEMBLY DATA

Table 49.1 - Sheave Assembly Data

Blower Type Digit 16	Sheave Digit 19	RPM Range	Blower RPM by Sheave Turns Open Setting (Approx.)										
			0	0.5	1	1.5	2	2.5	3	3.5	4	4.5	5
A or B (9-7 Blower)	A, B	656-1001	1001	967	932	898	863	829	794	760	725	691	656
	C, D, E	978-1265	1265	1236	1208	1179	1150	1122	1093	1064	1035	1007	978
	F, G	1150-1561	1561	1520	1479	1438	1397	1356	1314	1273	1232	1191	1150
	H, I	1526-1858	1858	1825	1792	1758	1725	1692	1659	1626	1592	1559	1526
	J, K	1763-2147	2147	2109	2070	2032	1993	1955	1917	1878	1840	1801	1763
C or D (9-9 Blower)	A, B	656-1001	1001	967	932	898	863	829	794	760	725	691	656
	C, D, E	978-1265	1265	1236	1208	1179	1150	1122	1093	1064	1035	1007	978
	F, G, H	1150-1561	1561	1520	1479	1438	1397	1356	1314	1273	1232	1191	1150
	I, J, K	1526-1858	1858	1825	1792	1758	1725	1692	1659	1626	1592	1559	1526
	L, M, N	1763-2147	2147	2109	2070	2032	1993	1955	1917	1878	1840	1801	1763
E or F (12-12 Blower)	A, B	468-715	715	690	666	641	616	592	567	542	517	493	468
	C, D, E	644-874	874	851	828	805	782	759	736	713	690	667	644
	F, G, H	863-1078	1078	1057	1035	1014	992	971	949	928	906	885	863
	I, J, K, Q	1029-1332	1332	1302	1271	1241	1211	1181	1150	1120	1090	1059	1029
	L, M, N	1150-1438	1438	1409	1380	1352	1323	1294	1265	1236	1208	1179	1150
	O, P	1327-1659	1659	1626	1593	1559	1526	1493	1460	1427	1393	1360	1327
G or H (15-15 Blower)	A, B, C	410-625	625	604	582	561	539	518	496	475	453	432	410
	D, E, F	568-771	771	751	730	710	690	670	649	629	609	588	568
	G, H, I	767-958	958	939	920	901	882	863	843	824	805	786	767
	J, K, L, O	934-1136	1136	1116	1096	1075	1055	1035	1015	995	974	954	934
	M, N	1136-1380	1380	1356	1331	1307	1282	1258	1234	1209	1185	1160	1136
I or J (18-18 Blower with Under 15 HP Motor)	A, B, C	491-649	649	633	617	602	586	570	554	538	523	507	491
	D, E, F, G	586-744	744	728	712	697	681	665	649	633	618	602	586
	H, I, J	682-821	821	807	793	779	765	752	738	724	710	696	682
	K, L, M, N	821-1009	1009	990	971	953	934	915	896	877	859	840	821
	O, P, Q, R	995-1161	1161	1144	1128	1111	1095	1078	1061	1045	1028	1012	995
	S, T, U	1101-1285	1285	1267	1248	1230	1211	1193	1175	1156	1138	1119	1101
K (18-18 Blower with 15 HP Motor & Up)	A, B, G, H	826-1009	1009	991	972	954	936	918	899	881	863	844	826
	C, D, I, J	995-1161	1161	1144	1128	1111	1095	1078	1061	1045	1028	1012	995
	E, F, K, L	1101-1285	1285	1267	1248	1230	1211	1193	1175	1156	1138	1119	1101
	M, N	1232-1438	1438	1417	1397	1376	1356	1335	1314	1294	1273	1253	1232
L (20-18 Blower)	A, B	491-649	649	633	617	602	586	570	554	538	523	507	491
	C, D, E	626-765	765	751	737	723	709	696	682	668	654	640	626
	F, G, H, I, J, K	765-901	901	887	874	860	847	833	819	806	792	779	765
	L, M, N, O, P, Q	901-1059	1059	1043	1027	1012	996	980	964	948	933	917	901
	R, S, T, U, V	995-1161	1161	1144	1128	1111	1095	1078	1061	1045	1028	1012	995
	W, X, Y, Z	1101-1285	1285	1267	1248	1230	1211	1193	1175	1156	1138	1119	1101

DIMENSIONS - UNIT

Figure 50.1 - Separated Combustion Blower Package Unit (Model Digit 2=B, Digit 16=A through H) ⑥

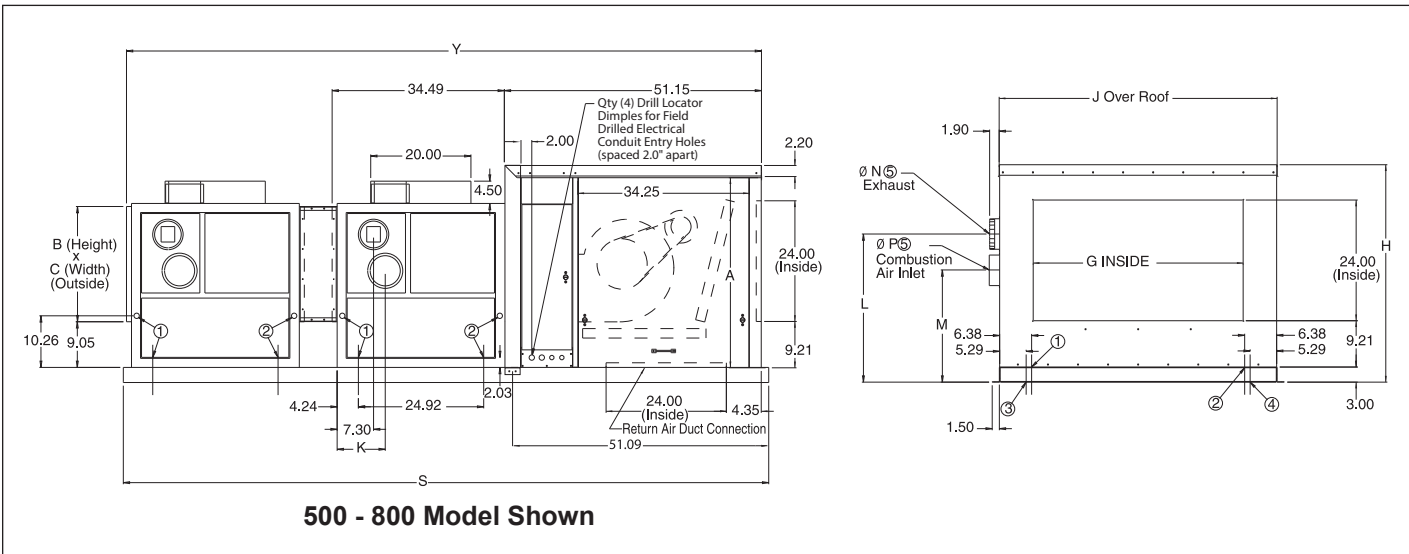

Figure 50.2 - Separated Combustion Cooling Package Unit (Model Digit 2=C, Digit 16=A through H) ⑥

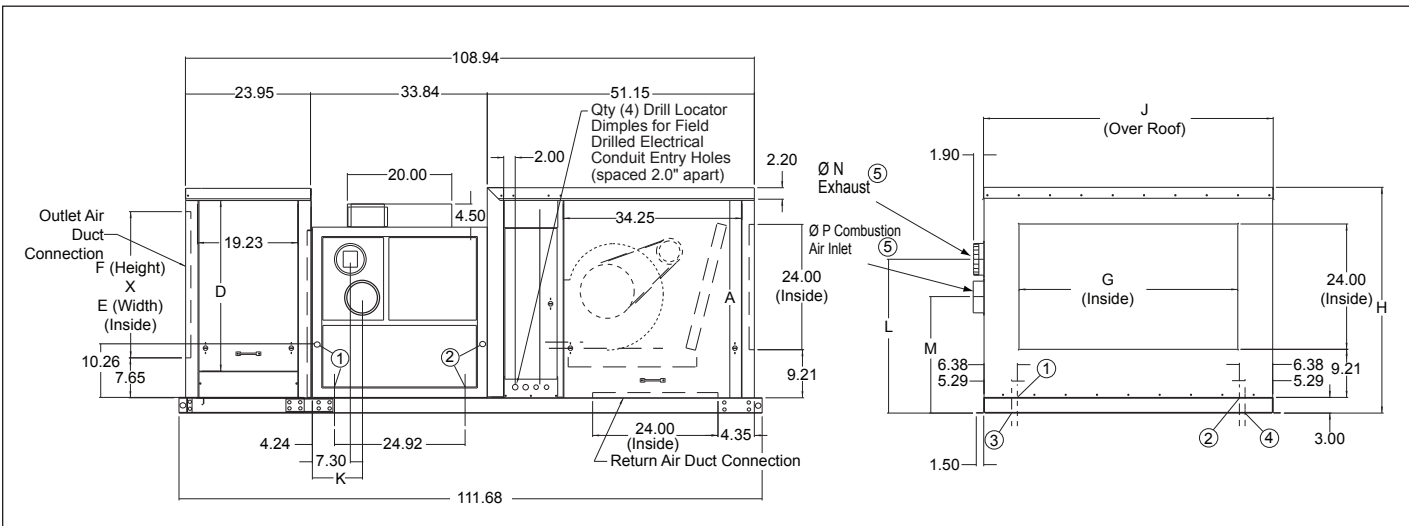

Table 50.1 - Indoor Separated Combustion Unit Dimensions (Model Digit 2=B or C, Digit 16=A through H) ⑥

Model Size	Blower Type (Digit 16)	Qty. of Furnaces	Dimensions																	Gas Conn.
			A	B	C	D	E	F	G	H	J	K	L	M	N ⑤	P ⑤	S	Y		
100/125	All	1	33.75	18.90	17.67	28.75	21.00	25.00	20.02	39.23	34.56	10.26	23.08	18.19	3.86	4.17	87.77	85.69	1/2	
150/175	All	1	33.75	18.90	21.95	28.75	24.00	25.00	23.99	39.23	38.82	10.26	23.08	18.19	3.86	4.17	87.77	85.69	1/2	
200/225	All	1	37.75	22.90	24.05	32.75	27.00	28.00	23.99	43.23	40.94	9.60	26.43	19.21	5.86	6.18	87.77	85.69	1/2	
250/300	E, F, G, or H	1	37.75	22.90	27.05	32.75	30.00	28.00	29.96	43.23	44.05	9.60	26.43	19.21	5.86	6.18	87.77	85.69	3/4	
350/400	E, F, G, or H	1	37.75	22.90	38.60	32.75	42.00	28.00	41.90	43.23	55.57	9.60	26.43	19.21	5.86	6.18	87.77	85.69	3/4	
500/600	G or H	2	37.75	22.90	27.05	32.75	n/a	n/a	29.96	43.23	44.05	9.60	26.43	19.21	5.86	6.18	128.77	126.78	3/4	
700/800	G or H	2	37.75	22.90	38.60	32.75	n/a	n/a	41.90	43.23	55.57	9.60	26.43	19.21	5.86	6.18	128.77	126.78	3/4	

- ① For Right Hand Access Units - Location of drill locator dimples/knockouts for field drilled gas connection entry holes - one side of unit and one on bottom.
- ② For Left Hand Access Units - Location of drill locator dimples/knockouts for field drilled gas connection entry holes - one side of unit and one on bottom.
- ③ For Right Hand Access Units - Location of drill locator dimples for field drilled electrical connection entry holes - identical sizes as side electrical connections.
- ④ For Left Hand Access Units - Location of drill locator dimples for field drilled electrical connection entry holes - identical sizes as side electrical connections.
- ⑤ Nominal vent pipe size is 4" (Models 100-175) and 6" (Models 200-800). Exhaust pipe installed over collar. Combustion air pipe installed collar.
- ⑥ All dimensions shown are in inches.

DIMENSIONS - UNIT

Figure 51.1 - Separated Combustion Blower Package Unit (Model Digit 2=B, Digit 16=I,J,K, or L) ⑦

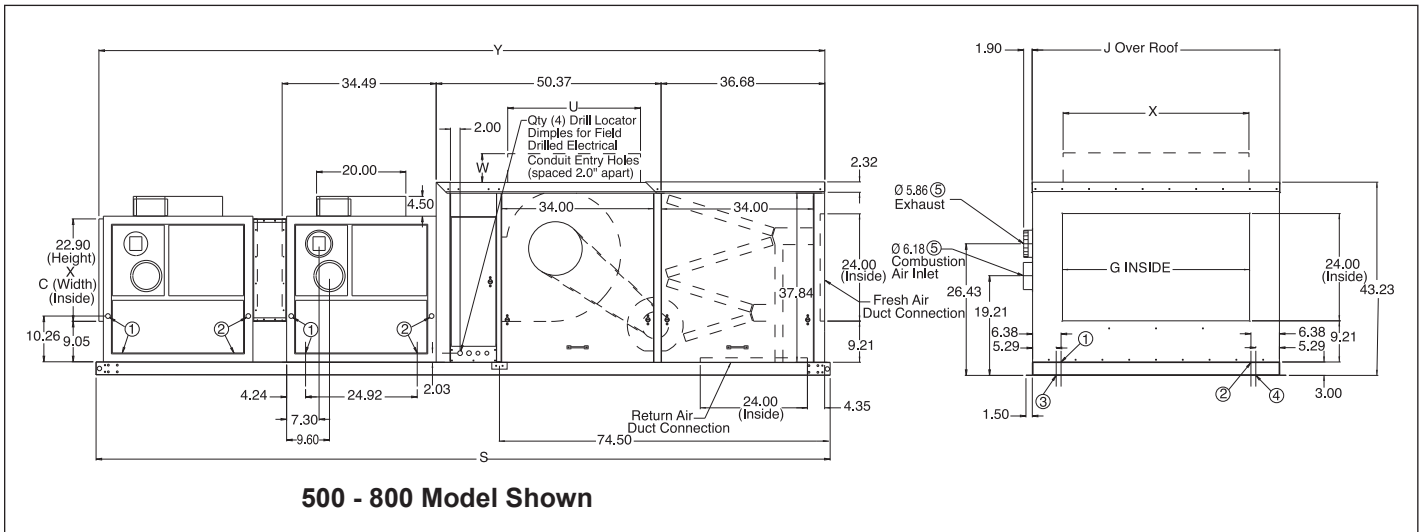

500 - 800 Model Shown

Figure 51.2 - Separated Combustion Cooling Package Unit (Model Digit 2=C, Digit 16=I,J,K, or L) ⑦

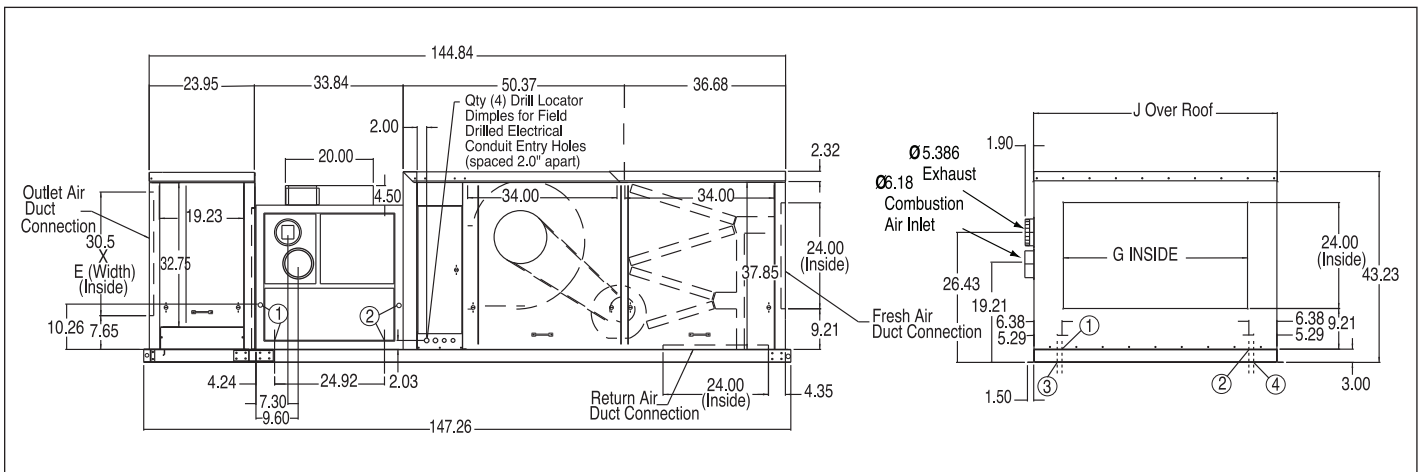

Table 51.1 - Indoor Separated Combustion Unit Dimensions (Model Digit 2=B or C, Digit 16=I,J,K, or L) ⑦

Model Size	Blower Type (Digit 16)	Qty. of Furnaces	Dimensions (Inches)								Gas Conn.	
			C	E	G	J	S	U ^⑥	W ^⑥	X ^⑥		Y
250/300	I, J, or K	1	27.05	30.00	29.96	44.05	123.63	n/a	n/a	n/a	121.53	3/4
350/400	I, J, or K	1	38.60	42.00	41.90	55.57	123.63	n/a	n/a	n/a	121.53	3/4
500/600	I, J, K, or L	2	27.05	n/a	29.96	44.05	164.63	29.74	6.50	41.62	162.63	3/4
700/800	I, J, K, or L	2	38.60	n/a	41.90	55.57	164.63	29.74	6.50	41.62	162.63	3/4
840/960	I, J, K, or L	3	38.60	n/a	41.90	55.57	205.77	29.74	6.50	41.62	203.72	3/4

- ① For Right Hand Access Units - Location of drill locator dimples/knockouts for field drilled gas connection entry holes - one side of unit and one on bottom.
- ② For Left Hand Access Units - Location of drill locator dimples/knockouts for field drilled gas connection entry holes - one side of unit and one on bottom.
- ③ For Right Hand Access Units - Location of drill locator dimples for field drilled electrical connection entry holes - identical sizes as side electrical connections.
- ④ For Left Hand Access Units - Location of drill locator dimples for field drilled electrical connection entry holes - identical sizes as side electrical connections.
- ⑤ Nominal vent pipe size is 4" (Models 100-175) and 6" (Models 200-800). Exhaust pipe installed over collar. Combustion air pipe installed collar.
- ⑥ Applies to units with Digit 16 = L only.
- ⑦ All dimensions shown are in inches.

DIMENSIONS - UNIT

Figure 52.1 - Unit Base Dimensions ①

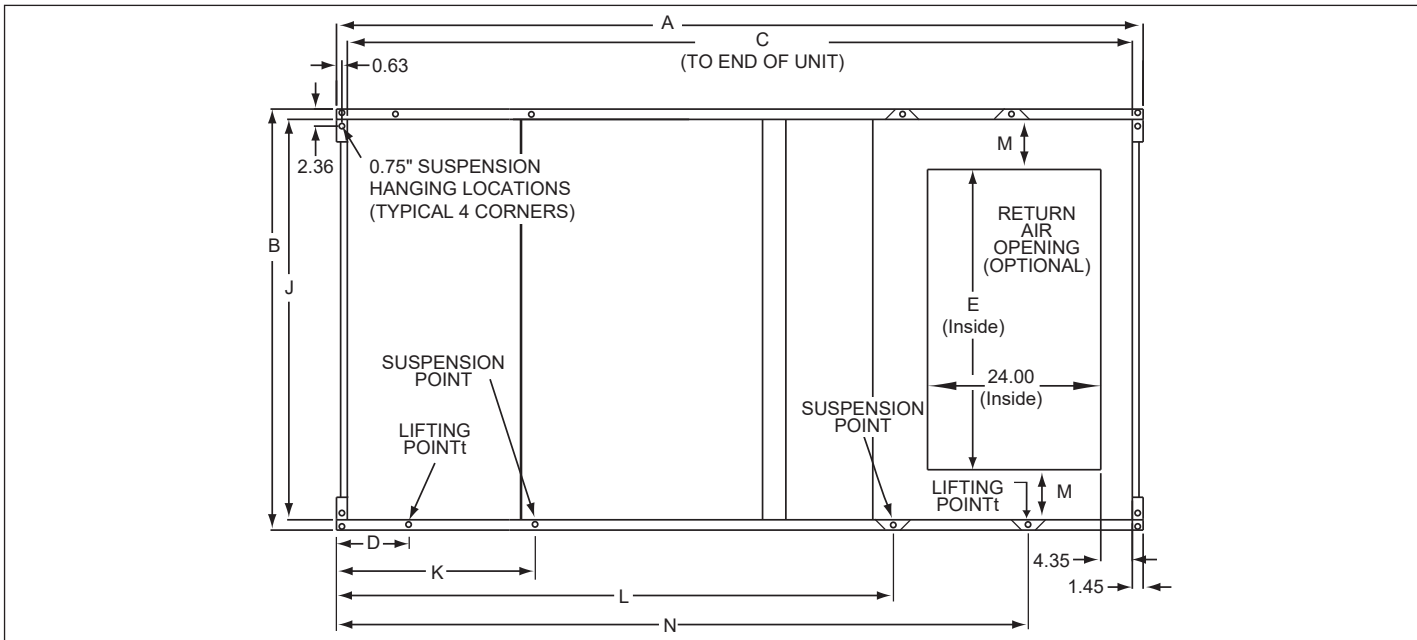

Table 52.1 - Indoor Separated Combustion Blower Package Dimensions for Model Digit 2=B ①

Model Size	Blower Type (Digit 16)	Dimensions (Inches)											
		A	B	C	D	E	F	G	N	K	L	J	M
100/125	All	87.77	37.36	84.73		19.52	81.88	56.96				34.50	7.49
150/175	All	87.77	41.61	84.73		23.49	81.88	56.96				38.75	7.63
200/225	All	87.77	43.71	84.73		23.49	81.88	56.96				40.85	8.69
250/300	E,F,G, or H	87.77	46.75	84.73		29.46	81.88	56.96				43.89	7.21
250/300	I, J, or K	123.62	46.75	120.57		29.46	117.73	92.81				43.89	7.21
350/400	E,F,G, or H	87.77	58.27	84.73		41.40	81.88	56.96				55.41	7.00
350/400	I, J, or K	123.62	58.27	120.57		41.40	117.73	92.81				55.41	7.00
500/600	G, or H	128.77	46.75	119.54	42.00	29.46	81.88	56.96	97.03	42.00		43.89	7.21
500/600	I, J, K, or L	164.63	46.75	155.41	42.00	29.46	117.73	92.81	125.70	90.15		43.89	7.21
700/800	G, or H	128.77	58.27	119.54	42.00	41.40	81.88	56.96	97.03	42.00		55.41	7.00
700/800	I, J, K, or L	164.63	58.27	155.41	42.00	41.40	117.73	92.81	125.70	90.15		55.41	7.00
840/960	I, J, K, or L	205.77	58.27	196.52	48.58	41.40	117.73	92.81	166.84	82.94	166.84	55.41	7.00

Table 52.2 - Indoor Separated Combustion Cooling Package Dimensions for Model Digit 2=C ①

Model Size	Blower Type (Digit 16)	Dimensions							
		A	B	C	E	F	G	J	M
100/125	All	111.75	37.36	108.75	19.52	81.88	56.96	34.50	7.49
150/175	All	111.75	41.61	108.75	23.49	81.88	56.96	38.75	7.63
200/225	All	111.75	43.71	108.75	23.49	81.88	56.96	40.85	8.69
250/300	E, F, G, or H	111.75	46.75	108.75	29.46	81.88	56.96	43.89	7.21
250/300	I, J, or K	147.60	46.75	144.60	29.46	117.73	92.81	43.89	7.21
350/400	E, F, G, or H	111.75	58.27	108.75	41.40	81.88	56.96	55.41	7.00
350/400	I, J, or K	147.60	58.27	144.60	41.40	117.73	92.81	55.41	7.00

① All dimensions shown are in inches.

DIMENSIONS - COOLING COILS

Figure 53.1 - DX Coil Drawing ③

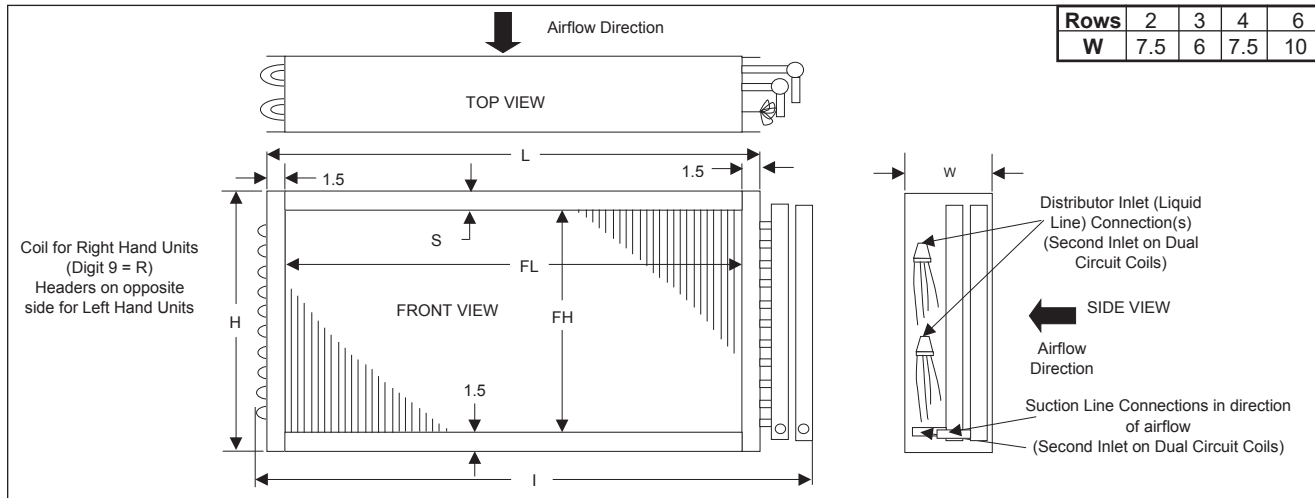

Table 53.1 - DX Coil Dimensions ③

Model Size	Cooling MBH	FH	H	S	DX - Single Circuit ①			DX - Dual Circuit ②		
					FL	I	L	FL	I	L
100/125	All	27.5	30.5	1.5	21	28	24	19.5	29.75	22.5
150/175	All	27.5	30.5	1.5	24	31	27	23	33.25	28.5
200/225	Below 185 MBH	32.5	34.5	0.5	27	34	30	25.5	35.75	28.5
	185 MBH & Up	32.5	34.5	0.5	27	34.5	30			
250/300	Below 185 MBH	32.5	34.5	0.5	30	37	33	28.5	38.75	31.5
	185 MBH & Up	32.5	34.5	0.5	30	37.5	33			
350/400	Below 185 MBH	32.5	34.5	0.5	42	49	45	40.25	50.5	43.25
	185 MBH & Up	32.5	34.5	0.5	42	49.5	45			

① Single Circuit DX coils have 1 each Suction Line and Liquid Lines. Refer to AccuSpec for line size diameters.

② Dual Circuit DX coils have 2 each Suction Line and Liquid Lines. Refer to AccuSpec for line size diameters.

③ All dimensions shown are in inches.

WEIGHTS

Table 54.1 - Unit Weights ①

Model Size	Blower Type (Digit 16)	Base Unit		Motor	Filters	Dampers		Insulation		Double Wall Liners	
		Digit 2				Fresh Air Only	Fresh & Return Air	Digit 2		Digit 2	
		B	C					B	C	B	C
100/125	All	409	519	See Motor Data	6	26	46	5	10	38	72
150/175	All	441	556		6	29	52	5	10	43	77
200/225	All	515	641		6	29	52	7	12	46	85
250/300	E, F, G, or H	568	698		8	33	60	7	12	46	87
250/300	I, J, or K	817	947		15	33	60	14	19	93	134
350/400	E, F, G, or H	652	801		12	38	70	7	12	53	101
350/400	I, J, or K	933	1082		17	38	70	14	19	96	144
500/600	G or H	843	n/a		8	33	60	7	n/a	46	n/a
500/600	I, J, K, or L	1092	n/a		15	33	60	14	n/a	93	n/a
700/800	G or H	981	n/a		12	38	70	7	n/a	53	n/a
700/800	I, J, K, or L	1262	n/a		17	38	70	14	n/a	96	n/a
840/960	I, J, K, or L	1591	n/a		17	38	70	14	n/a	96	n/a

① All weights in pounds and are approximate

Table 54.2 - Motor Weights ①

Supply Voltage (Digit 14)	Motor Type (Digit 18)	Motor Size (Digit 17)											
		A or L	B or M	C or N	D or P	E or Q	F or R	G or S	H or T	I or W	J or X	K or Y	V or Z
		1/3	1/2	3/4	1	1-1/2	2	3	5	7-1/2	10	15	20
A - 115/60/1ph	1 - ODP	25	23	25	32	40	49	81	-	-	-	-	-
	5 - TE	25	28	30	37	45	49	83	-	-	-	-	-
B - 208/60/1ph	1 - ODP	-	23	25	32	40	49	81	87	-	-	-	-
	5 - TE	-	28	30	37	45	49	83	86	-	-	-	-
C - 230/60/1ph	1 - ODP	25	23	25	32	40	49	81	87	-	-	-	-
	5 - TE	25	28	30	37	45	49	83	86	-	-	-	-
D - 208/60/3ph	1 - ODP	17	18	21	-	-	-	-	-	-	-	-	-
	2 - ODP HE	-	-	-	83	94	99	83	94	141	126	220	250
	5 - TE	15	23	26	-	-	-	-	-	-	-	-	-
	6 - TE HE	-	-	-	68	66	66	92	99	158	200	259	368
E - 230/60/3ph	1 - ODP	17	18	21	-	-	-	-	-	-	-	-	-
	2 - ODP HE	-	-	-	40	46	54	87	94	130	126	217	250
	5 - TEFC	15	23	30	-	-	-	-	-	-	-	-	-
	6 - TEFC HE	-	-	-	53	66	67	92	117	194	213	322	368
F - 460/60/3ph	1 - ODP	17	18	21	-	-	-	-	-	-	-	-	-
	2 - ODP HE	-	-	-	40	46	54	87	94	130	126	217	250
	5 - TE	15	23	30	-	-	-	-	-	-	-	-	-
	6 - TE HE	-	-	-	53	66	66	92	117	194	213	322	368
G - 575/60/3ph	1 - ODP	-	25	28	-	-	-	-	-	-	-	-	-
	2 - ODP HE	-	-	-	35	40	45	76	89	90	220	310	360
	5 - TE	-	24	33	-	-	-	-	-	-	-	-	-
	6 - TE HE	-	-	-	68	40	67	100	125	192	200	326	368

① All weights in pounds and are approximate.

MAINTENANCE

⚠ WARNING

When servicing or repairing this equipment, use only factory-approved service replacement parts. A complete replacement parts list may be obtained by contacting Modine Manufacturing Company. Refer to the rating plate on the appliance for complete appliance model number, serial number, and company address. Any substitution of parts or controls not approved by the factory will be at the owner's risk.

⚠ AVERTISSEMENT

Pour l'entretien et les réparations de cet appareil, utilisez uniquement des pièces d'origine certifiées. Pour la liste complète des pièces de rechange, consultez Modine Manufacturing Company. Le numéro de modèle complet, le numéro de série et l'adresse du fabricant figurent sur la plaque signalétique fixée à l'appareil. Toute substitution de pièce ou de commande non approuvée par le fabricant sera aux risques du propriétaire.

⚠ CAUTION

Do not reuse any mechanical or electrical component which has been wet. Such components must be replaced.

⚠ ATTENTION

Ne tentez pas de réutiliser un composant mécanique ou électrique qui a été mouillé. Ces composants doivent être remplacés.

IMPORTANT

To check most of the Possible Remedies in the troubleshooting guide listed in Table 58.1 refer to the applicable sections of the manual.

IMPORTANT

Pour essayer la plupart des solutions possibles suggérées dans le guide de dépannage du Table 58.1 reportez-vous aux sections correspondantes du manuel.

All heating equipment should be serviced before each heating season to assure proper operations. The following items may be required to have more frequent service schedule based on the environment in which the unit is installed, and the frequency of the equipment operation.

Electrical Wiring

The electrical wiring should be checked annually for loose connections or deteriorated insulation.

Blower Assembly

The blower assembly includes the bearings, drive sheaves and belts. Blower bearings should be checked and lubricated based on the blower manufacturer's recommendations. Bearings should also be checked for any unusual wear and replaced if needed.

Drive sheaves should be checked at the same time the bearings are inspected. Check to make sure the sheaves are in alignment and are securely fastened to the blower and motor shafts. Belt tension should be rechecked shortly after the unit has been installed to check for belt stretching. After the initial start-up, monthly checks are recommended.

Filters

If the unit is supplied with a dirty filter switch and light, clean or replace the filters any time the dirty filter light comes on.

Units which do not have a dirty filter warning light should have the filters checked monthly. Clean or replace if necessary. In dirty atmospheres, filter maintenance may be required more often.

Figure 55.1 - Filter Replacement Arrangement for STANDARD Blower Size (Model Digit 16=A through H)

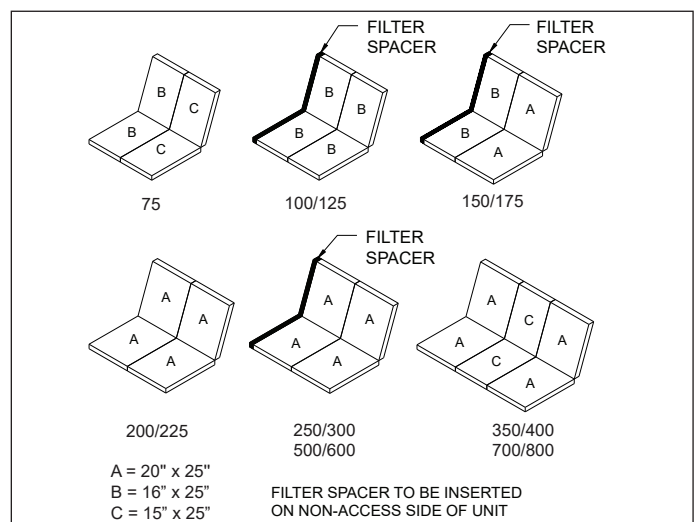
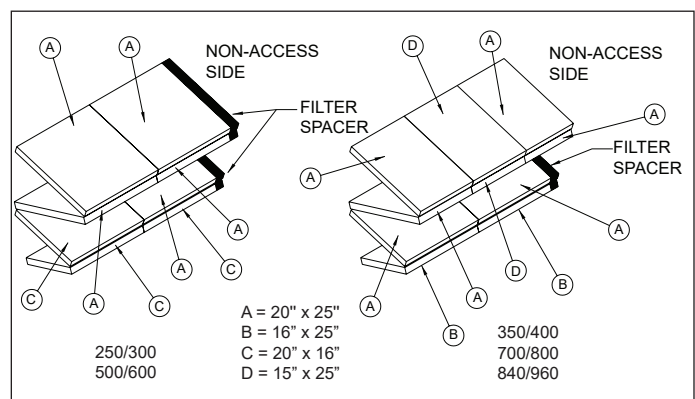

Figure 55.2 - Filter Replacement Arrangement for EXTENDED Blower Size (Model Digit 16 = I, J, K, or L)



MAINTENANCE

Cooling Coil Maintenance

1. Periodically, inspect the coil for signs of corrosion and leaks. Repair and replacement of the coil and the connecting piping, valves, etc., must be performed as needed by a qualified technician.
2. Should the coil surface need cleaning, caution should be exercised in selecting the cleaning solution as well as the cleaning equipment. Improper selection can result in damage to the coil and/or health hazards. Cleaning solutions must not be corrosive or cause damage to copper tube/aluminum fin coils. Clean the coil from the leaving air-side so that foreign material will be washed out of the coil rather than pushed further in. Be sure to carefully read and follow the cleaning fluid manufacturer's recommendations before using any cleaning fluid.
3. For DX coils, replace the filter dryer(s) as needed.

Cooling Coil Drain Pan and Drain System

The drain pan, trap, and drain pipe must be cleaned regularly to avoid blockage that can reduce or stop water flow as follows:

1. At the beginning of the cooling season, inspect and clean the entire cooling coil cabinet and condensate drain pan to remove contaminants.
2. Inspect and clean the condensate drain trap and piping. The use of a cleanout opening at the top of the trap can help facilitate this maintenance.
3. Fill the trap with water to ensure proper operation and replace the cap on the cleanout opening to close the system.
4. During the end of cooling season shutdown of the system, disconnect and remove all water from the trap and drain to prevent freeze damage. If local building codes permit, the trap may be filled with an antifreeze solution.
5. If the unit is used year round, regularly inspect and clean the cooling coil cabinet, condensate drain pan, and trap/drain system to ensure proper function.
6. Depending on climate, freeze protection of the trap may be required during non-cooling days.

Duct Furnace

When providing annual maintenance for the duct furnace, keep the unit free from dust, dirt, grease and foreign matter. Pay particular attention to:

1. The power exhauster discharge opening and the combustion air inlet louvers.
2. The burner ports and pilot burner orifices (avoid the use of hard, sharp instruments capable of damaging surfaces for cleaning these ports). To check the burner port and pilot burner orifice, see Burner and Pilot Assembly Removal.
3. The air shutters and main burner orifices (avoid the use of hard, sharp instruments capable of damaging surfaces for cleaning these orifices). To check the air shutters and main burner orifices, see for Manifold Assembly Removal.

The heat exchanger should be checked annually for cracks and discoloration of the tubes. If a crack is detected, the heat exchanger should be replaced before the unit is put back into service. If the tubes are dark gray, airflow across the heat exchanger should be checked to insure that a blockage has not occurred or the blower is operating properly.

Gas Piping & Controls

The gas valves and piping should be checked annually for general cleanliness and tightness.

The gas controls should be checked to insure that the unit is operating properly.

Manifold Assembly Removal

To remove the manifold (Refer to Figure 56.1)

1. Shut off gas and electric supply.
2. Disconnect gas manifold at ground union joint.
3. Remove the two screws holding the manifold to the heat exchanger support.
4. Slide the manifold through the manifold bracket.
5. Clean the orifices and adjust the air shutters as necessary.
6. Follow steps 3-6 in reverse order to install the manifold assembly.
7. Turn on the electric and gas supply.
8. Check the ground union joint for leaks with a soap solution. Tighten if necessary.

Figure 56.1 - Manifold Assembly Removal

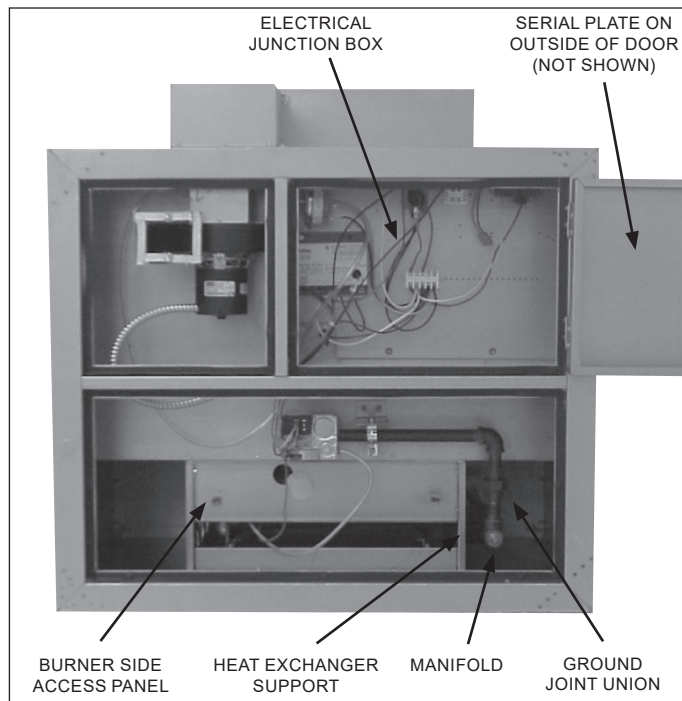

MAINTENANCE

Burner and Pilot Assembly Removal

To remove the burner (Refer to Figure 57.1)

1. Shut off gas and electric supply.
2. Disconnect the pilot supply line from the gas valve.
3. Disconnect the ignition cable from the ignition controller (located in the electrical junction box). Feed the cable through the bushing in the bottom of the electrical junction box.
4. Remove the screws holding the burner side access panel. Attached to the panel are the burner retaining pins that align the burner.
5. Slide the burner assembly out. The pilot is attached to the burner assembly.
6. Examine the burner and pilot assembly for cleanliness and/or obstructions as necessary (see Duct Furnace for cleaning instructions).
7. Replace the burner assembly in reverse order. In replacing the burner, be certain that the rear burner slots are located properly on the burner retaining pins. Do not force the burner side access panel, it will not fit if the burner is not properly aligned.
8. Reconnect the ignition cable and pilot gas supply line.
9. Turn on the electric and gas supply.

Figure 57.1 - Burner and Pilot Assembly Removal

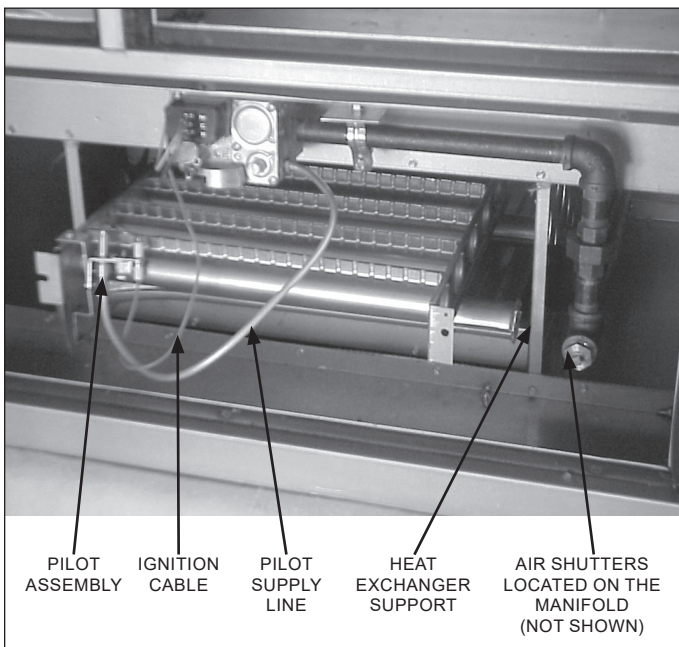

SERVICE & TROUBLESHOOTING

⚠ WARNING

When servicing or repairing this equipment, use only factory-approved service replacement parts. A complete replacement parts list may be obtained by contacting Modine Manufacturing Company. Refer to the rating plate on the unit for complete unit model number, serial number, and company address. Any substitution of parts or controls not approved by the factory will be at the owner's risk.

⚠ AVERTISSEMENT

Pour l'entretien et les réparations de cet appareil, utilisez uniquement des pièces d'origine certifiées. Pour la liste complète des pièces de rechange, consultez Modine Manufacturing Company. Le numéro de modèle complet, le numéro de série et l'adresse du fabricant figurent sur la plaque signalétique fixée à l'appareil. Toute substitution de pièce ou de commande non approuvée par le fabricant sera aux risques du propriétaire.

⚠ CAUTION

Do not reuse any mechanical or electrical component which has been wet. Such component must be replaced.

⚠ ATTENTION

Ne tentez pas de réutiliser un composant mécanique ou électrique qui a été mouillé. Ces composants doivent être remplacés.

IMPORTANT

To check most of the Possible Remedies in the troubleshooting guide listed in Table 58.1 refer to the applicable sections of the manual.

IMPORTANT

Pour essayer la plupart des solutions possibles suggérées dans le guide de dépannage du Table 58.1 reportez-vous aux sections correspondantes du manuel.

Table 58.1 - Troubleshooting

Trouble	Possible Cause	Possible Remedy
Pilot does not light	1. Main gas is off.	1. Open manual gas valve.
	2. Power supply is off.	2. Turn on main power.
	3. Air in gas line.	3. Purge gas line.
	4. Dirt in pilot orifice.	4. Check for plugged pilot orifice and clean with compressed air if necessary.
	5. Gas pressure out of proper range.	5. Adjust to a minimum for Natural Gas - 6" W.C. Minimum for Propane Gas - 11" W.C. Maximum 14" W.C.
	6. Pilot valve does not open.	6. Check wiring for 24 volts to valve.
	a. Defective ignition controller.	a. Replace ignition controller.
	b. Defective gas valve.	b. Replace gas valve.
	7. No Spark at ignitor.	7
	a. Loose wire connections.	a. Check all ignition controller wiring.
b. Pilot sensor is grounded.	b. Replace sensor if cracked or worn	
c. Defective ignition controller.	c. Replace ignition controller.	
8. Safety device has cut power.	8. Check all safety devices (High limit, air flow proving switch, power exhauster centrifugal switch, gas pressure switches, etc.) Determine and correct problem. Reset if necessary.	
Main burners do not light (Pilot is lit)	1. Defective valve.	1. Replace valve.
	2. Loose wiring.	2. Check wiring to gas valve.
	3. Defective pilot sensor	3. Replace pilot sensor.
	4. Defective ignition controller.	4. Replace ignition controller.
	5. Improper thermostat wiring.	5. Verify wiring compared to wiring diagram.
Lifting Flames (See Figure 60.1)	1. Too much primary air.	1. Reduce primary air.
	2. Main pressure set too high.	2. Adjust to a maximum of 14" W.C.
	3. Orifice too large.	3. Check orifice size with those listed on the serial plate.
Yellow Tipping (With propane gas, some yellow tipping is always present.)	1. Insufficient primary air.	1. Increase primary air.
	2. Dirty orifice.	2. Check orifices and clean with compressed air if necessary.
	3. Misaligned orifice.	3. Check manifold, replace if necessary.
Flashback	1. Too much primary air.	1. Reduce primary air.
	2. Main pressure set too high.	2. Adjust to a maximum of 14" W.C.
	3. Orifice too large.	3. Check orifice size with those listed on the serial plate.

SERVICE & TROUBLESHOOTING (CONTINUED)

Troubleshooting (Continued)

Trouble	Possible Cause	Possible Remedy
Floating Flames (See Figure 60.2)	1. Insufficient primary air.	1. Increase primary air.
	2. Main pressure set too high.	2. Adjust to a maximum of 14" W.C.
	3. Orifice too large.	3. Check orifice size with those listed on the serial plate.
	4. Blocked vent cap.	4. Clean louvers in vent cap.
Flame Rollout (See Figure 60.3)	1. Main pressure set too high.	1. Adjust to a maximum of 14" W.C.
	2. Orifice too large.	2. Check orifice size with those listed on the serial plate.
	3. Blocked vent cap.	3. Clean louvers in vent cap.
Not Enough Heat	1. Unit cycling on high limit. ①	1.
	a. Obstructions/leaks in duct system.	a. Clean/correct duct system.
	b. Main pressure set too high.	b. Adjust to a maximum of 14" W.C.
	c. Blower motor not energized.	c. Check that blower motor operates within 45 seconds of when gas controls are energized.
	d. Loose belt	d. Adjust belt tension.
	e. Blower speed too low.	e. Check/correct blower drive settings for proper rpm.
	f. Blocked/damaged venting system.	f. Check/correct venting system.
	g. Defective high limit switch.	g. Replace high limit switch.
	2. Main pressure set too low.	2. Adjust main gas pressure. (Minimum for Natural Gas — 6" W.C. Minimum for Propane Gas — 11" W.C.)
	3. Too much outside air.	3. Adjust outside air damper to decrease outside air percentage (if possible).
	4. Thermostat malfunction.	4. Check/replace thermostat.
	5. Gas controls wired incorrectly.	5. Check unit wiring against the wiring diagram.
	6. Unit undersized.	6. Check design conditions. If unit is undersized, an additional unit(s) or other heat source must be added.
Too Much Heat	1. Thermostat malfunction.	1. Check/replace thermostat.
	2. Gas controls do not shut-off.	2.
	a. Gas controls wired incorrectly.	a. Check unit wiring against the wiring diagram.
	b. Short circuit.	b. Check for loose or worn wires.
Power Exhauster Motor Will Not Start	3. Main gas pressure set too high.	3. Adjust to a maximum of 14" W.C.
	4. Defective gas valve.	4. Replace gas valve.
	1. Power supply is off.	1. Turn on main power.
	2. No 24V power to thermostat.	2. Check control transformer.
	3. Thermostat malfunction.	3. Check/replace thermostat.
	4. Defective power exhauster relay.	4. Replace power exhauster relay.
	5. Defective power exhauster motor.	5. Replace power exhauster motor.

① The duct furnace comes standard with an automatic reset high limit switch that will shut-off the gas should the discharge air temperature become excessive. See Figure 33.1, indicator (49) for the location of the standard automatic reset high limit switch. The switch should operate only when something is wrong with the unit operation. Anytime the switch operates, correct the difficulty immediately or serious damage may result. If the switch cuts off the gas supply during normal operation, refer to the "Not Enough Heat" section of Table 58.1.

SERVICE & TROUBLESHOOTING

Figure 60.1 - Lifting Flame Condition

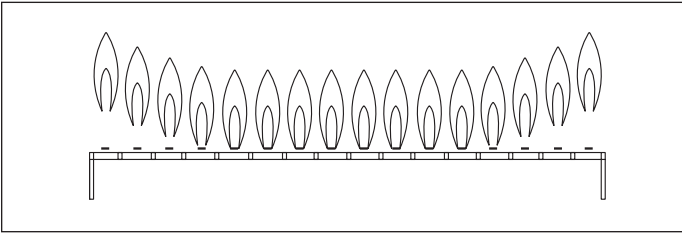

Figure 60.2 - Floating Flame Condition

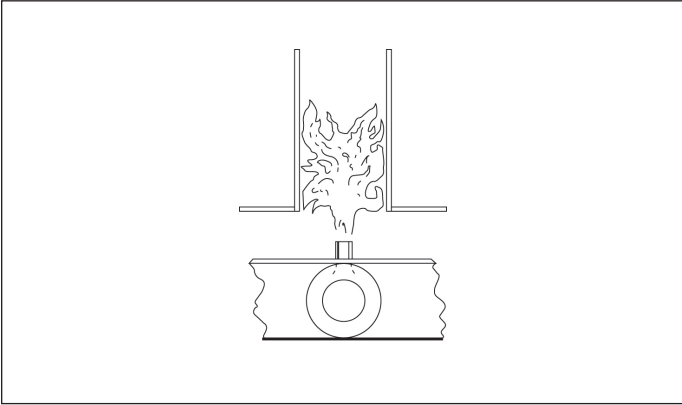
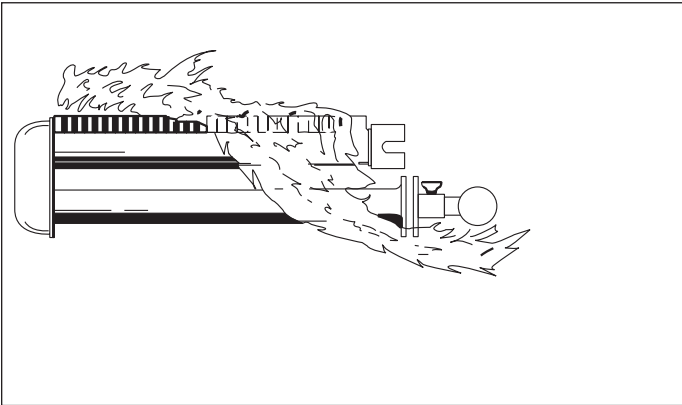

Figure 60.3 - Flame Rollout Appearance



START-UP CHECKLIST

Job Name:	Date:	
Address:	Model No.:	
City & State:	Order No.:	
Start-Up Check List "ALL ITEMS MUST BE CHECKED"	Serial No.:	
<ol style="list-style-type: none"> 1. All shipping straps, braces, tie downs removed? ___ Yes ___ No 2. Unit installed level and secure? ___ Yes ___ No 3. Gas burner properly located and aligned? ___ Yes ___ No 4. Blower and motor alignment okay? ___ Yes ___ No 5. Bearings aligned and tight on shaft/bearing supports? ___ Yes ___ No 6. Electrical connections checked and secure? ___ Yes ___ No 7. Gas piping checked and tightened if necessary? ___ Yes ___ No 8. Any visible damage to unit? ___ Yes ___ No Describe: _____ If damaged, was the damage repaired? ___ Yes ___ No 9. Air inlet and discharge checked for obstructions? ___ Yes ___ No 10. Bearings checked for proper lubrication? ___ Yes ___ No 11. Filters in place and correct to direction of air flow? ___ Yes ___ No 12. Belt tension checked? ___ Yes ___ No 13. Electric supply to unit: _____ Volts, _____ Hz, _____ Phase 14. Gas supply to unit: _____ Natural, _____ Propane 15. Gas supply pressure to unit: _____ " W.C., _____ PSIG 16. Inlet and/or discharge dampers operating correctly? ___ Yes ___ No 17. Blower rotation correct? ___ Yes ___ No 18. Blower speed: Hi Speed _____ RPM, Lo Speed _____ RPM 19. Motor speed: Hi Speed _____ RPM, Lo Speed _____ RPM 20. Is unit noisy? Excessive vibration? ___ Yes ___ No 21. Motor voltage: L1 _____ V, L2 _____ V, L3 _____ V 22. Motor amps: L1 _____ Amp, L2 _____ Amp, L3 _____ Amp 23. High temperature limit control continuity checked? ___ Yes ___ No 24. Burner light off ___ Yes ___ No Low Fire: Does entire burner light off? Hi Fire: Burner pressure reading? _____ " W.C. Is flame clean and stable? ___ Yes ___ No Does flame modulate in response to temperature control(s)? ___ Yes ___ No 25. Gas input checked? ___ Yes ___ No Input at maximum firing rate: _____ Btu/Hr Input at minimum firing rate: - _____ Btu/Hr 26. Gas piping checked for and free of leaks? ___ Yes ___ No 27. Has wiring been verified to match the unit wiring diagram? ___ Yes ___ No 28. Have all the modes of the sequence of operation been verified and tested? ___ Yes ___ No 29. What optional and/or accessory control devices have been set? Device: _____ Setting: _____ (°F/psi/Inches W.C./etc.) ___ Yes ___ No Device: _____ Setting: _____ (°F/psi/Inches W.C./etc.) ___ Yes ___ No Device: _____ Setting: _____ (°F/psi/Inches W.C./etc.) ___ Yes ___ No 		

Customer/Owner instructed in operation and maintenance of unit? ___ Yes ___ No

Name of Person(s) Instructed: _____

Comments: _____

Start-Up Company Name: _____ Phone: _____

Signature: _____ Date: _____

MODEL DESIGNATIONS

Model Identification

Duct furnace/make-up air units contain an ETL/ETL Canada certified indoor duct furnace. This duct furnace is combined with either a blower section or a blower and cooling section to make a complete make-up air or heating/ventilating/ cooling unit that is ETL/ETL Canada certified. For this reason, two identification plates are used on these models. The Serial Plate is used to identify the duct furnace and its components. The Model Identification Plate is used to identify the complete model, including blower and cooling sections.

Replacement Parts Ordering

When servicing, repairing or replacing parts on these units, locate the model identification plate of the unit and always give the complete Model Number and Serial Number from the model identification plate. The model identification plate is located on the blower section electrical compartment door. For a complete description of the model number, see Model Nomenclature on page 63.

Figure 62.1 - Furnace Serial Plate Location

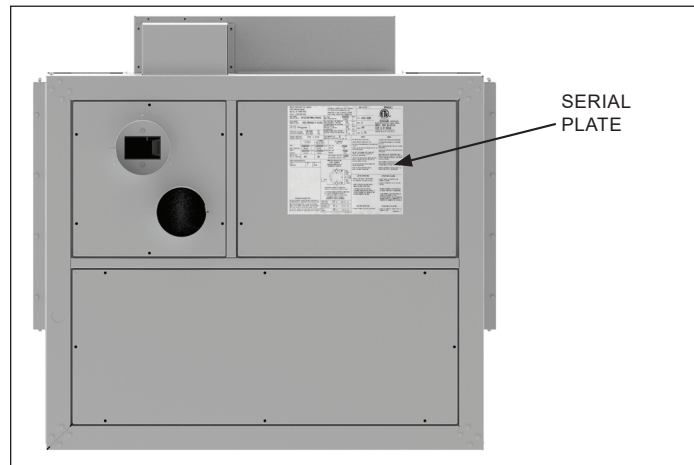

Figure 62.2 - Furnace Serial Plate (sample shown, actual data may vary)

Modine Manufacturing Company 1500 DeKoven Avenue Racine, WI 53403-2552 Phone: 1-800-828-4328		SEPARATED COMBUSTION DUCT FURNACE FOR INDUSTRIAL/COMMERCIAL USE CHAUDIÈRE À GAZ À CONDUIT SÉPARÉ POUR USAGE INDUSTRIEL/COMMERCIAL		Made in U.S.A.		APPROVALS	
MODEL NUMBER NUMÉRO DE MODÈLE: DFS200TMLP40D2		MIN. INPUT DEBIT CALORIFIQUE MIN. 80000 23424 BTU/HR V		VOLTS 200-208		ETL US	
SERIAL NUMBER NUMÉRO DE SÉRIE: 0917093017-2155		MIN. INLET PRESS. FOR PURPOSE OF INPUT ADJUSTMENT / PRESSION D'ALIMENTATION EN GAZ MIN. ADMISE 11 2.74 IN W.C. IPa		PHASE 1		Intertek 9900100	
TYPE OF GAS TYPE OF GAZ: Propane		MANIFOLD PRESSURE PRESSION A LA TUBULURE D'ALIMENTATION 10 2.49 IN W.C. IPa		HERTZ 60		ANSI Z83.8-2016 CSA 2.6-2016	
TEMPERATURE RISE RANGE ELEVATION DE TEMPERATURE: 20-60 °F 11-33 °C		MAXIMUM EXTERNAL STATIC PRESSURE PRESSION STATIQUE EXTERIEUR MAXIMUM 3 0.75 IN W.C. IPa		AMPS 1.76		APPROVED FOR USE IN MASSACHUSETTS APPROVED FOR USE IN CA BY THE CEC	
CATEGORY (HORIZ/VERT) CATÉGORIE (HORIZ/VERT): III / III		VENT CONNECTOR SIZE CONNECTEUR DE VENTILATION: 6 IN 15.24 CM		GENERAL			
INPUT DEBIT CALORIFIQUE: 200000 58560 BTU/HR V		(IN CANADA) 2000 TO 4500 FT. 610 ET 1370 M. 180000 BTU/HR 52704 V		AIR THROUGHPUT DEBIT D'AIR: 2500 71 CM MIN		FOR INDOOR INSTALLATIONS ONLY. MINIMUM AMBIENT TEMPERATURE -40°F. FOR INSTALLATION DOWNSTREAM OF REFRIGERATION SYSTEMS. INSTALL ON THE POSITIVE PRESSURE SIDE OF AIR CIRCULATING BLOWER.	
OUTPUT RENDIMENT: 162000 47434 BTU/HR V		MIN. CFM CM MIN: 2500 71		MAX. CFM CM MAX: 7500 212		SEULEMENT POUR INSTALLATION INTÉRIÈRE LA TEMPERATURE MINIMUM DE L'AIR DEHORS EST -40°C POUR L'INSTALLATION QUE SUEVE LES SYSTEMS REFRIGERANTS. INSTALLER DU CÔTÉ DE LA PRESSION POSITIVE VENTILATEUR.	
ORIFICE SIZE DIM. DE L'INJECTEUR: 42		MIN VARIABLE SPEED CFM * CM * 1650 47		FOR UNITS WITH MANUAL RESET HIGH LIMIT SWITCH, RESET BUTTON IS LOCATED IN ELECTRICAL JUNCTION BOX. (IN USA) FOR INSTALLATIONS ABOVE 2000 FEET, DEDUCT 4 PERCENT FOR EACH 1000 FEET OF ELEVATION ABOVE SEA LEVEL.			
POWER EXHAUSTER MOTOR DATA		COMBUSTIBLE MATERIALS AND SERVICE CLEARANCES MATÉRIAUX COMBUSTIBLES ET DÉGAGEMENTS D'ENTRETIEN		SEE INSTALLATION AND SERVICE MANUAL FOR VENTING INSTRUCTIONS REFER TO INSTALLATION AND SERVICE MANUAL FOR MORE INSTRUCTIONS			
VOLTS: 208/230		AMPS: 1		HP: 0.08		VOIR LE MANUEL D'INSTALLATION ET DE SERVICE POUR D'INSTALLATION D'INSTRUCTIONS LES SYSTEMS D'ÉVACUATION D'INSTRUCTIONS POUR PLUS D'INSTRUCTIONS	
CERTAINING REPLACEMENT PARTS For parts ordering, contact the parts wholesaler or the manufacturer's representative serving your area. When inquiring about parts, always provide model number, serial number, description, and part number. When ordering parts, provide part number listed. For service, contact your local qualified installation and service contractor or appropriate utility company.		ACCESS SIDE CÔTÉ D'ACCÈS: 27 IN 68.6 CM		NON-ACCESS SIDE CÔTÉ NON-ACCÈS: 6 IN 15.2 CM		LIGHTING INSTRUCTIONS 1. OPEN ALL GAS VALVES. TURN ON POWER. 2. SET THERMOSTAT TO DESIRED SETTING. REFER TO INSTALLATION AND SERVICE MANUAL FOR MORE INSTRUCTIONS * FOR UNITS WITH TWO STAGE OR ELECTRONIC MODULATING GAS CONTROLS, A FACTORY DISCHARGE AIR CONTROLLER AND NO ROOM THERMOSTAT INCLUDED.	
3 IN MINIMUM CLEARANCE TO COMBUSTIBLE MATERIAL IS FROM OUTSIDE SURFACE OF VENT LA DISTANCE MINIMUM DE MATÉRIAU COMBUSTIBLE DE 7.6CM EST DÉTERMINÉE À PARTIR DE L' EXTERIEUR DU CONDUIT DE VENTILATION. RECOMMENDED SERVICE CLEARANCES DÉGAGEMENT DE SERVICE RECOMMENDÉ		TOP DÉSSUS: 10 IN 25.4 CM		SHUT DOWN INSTRUCTIONS: 1. TURN OFF POWER & CLOSE ALL GAS VALVES.		INSTRUCTIONS D'ALLUMAGE 1. OUVRIR TOUTES LES ROBINETS À GAZ. DONNER LE COURANT. 2. RÉGLER LE THERMOSTAT SUR LA POSITION DÉSIRÉE. REFERER AU MANUEL D'INSTALLATION ET DE SERVICE POUR PLUS D'INSTRUCTIONS * POUR APPAREILS AVEC DEUX PHASES OU APPAREILS DE CONTRÔLE DE GAZ ÉLECTRONIQUES MODULÉS, UN AIR CONTRÔLEUR DÉGARGE INSTALLÉ À LA MANUFACTURE, ET THERMOSTAT DE CHAMBRE N'EST PAS INCLUS.	

Figure 62.3 - Model ID Plate Example (sample shown, actual data may vary)

MODEL IDENTIFICATION PLATE				MODEL NUMBER DBS960TMRHN20F2IQ5DDA00			
VOLTAGE 460V3~		HERTZ PHASE 60 3		SERIAL NUMBER 15100905051234-1111 1		ORDER 99999999 SPO 12345678	
MCC 3		KW (HP) 1.12 (1.5)		SHORT CIRCUIT CURRENT: 5KA RMS SYMMETRICAL, 460V MAXIMUM Refrigerant: R410a			
SUPPLY VOLTAGE 460V3~		HERTZ PHASE 60 3		FLA 5.2 MCA 6.9 MOP (TIME DELAY) 15			

MODEL NOMENCLATURE FOR SYSTEM UNITS

Model Nomenclature

1	2	3	4 5 6	7	8	9	10	11	12	13	14	15	16	17	18	19	20 21	22	23
PT	UC	V	MBH	HE	DS	AS	ATR	GT	GV	SS	SV	TR	BB	HP	MT	SA	AC	EC	CC

1 - Product Type (PT)

D or I - Indoor Indirect Fired Heating & Make-Up Air Unit

2 - Unit Configuration (UC)

B - Blower Package - Furnace & Blower

C - Cooling Package - Furnace, Blower, & Cooling Cabinet

3 - Venting (V)

S - Separated Combustion

4,5,6 - Furnace Input Rating (MBH) (Except for 840 & 960)

100 - 100,000 Btu/Hr Input	350 - 350,000 Btu/Hr Input
125 - 125,000 Btu/Hr Input	400 - 400,000 Btu/Hr Input
150 - 150,000 Btu/Hr Input	500 - 500,000 Btu/Hr Input
175 - 175,000 Btu/Hr Input	600 - 600,000 Btu/Hr Input
200 - 200,000 Btu/Hr Input	700 - 700,000 Btu/Hr Input
225 - 225,000 Btu/Hr Input	800 - 800,000 Btu/Hr Input
250 - 250,000 Btu/Hr Input	840 - 1,050,000 Btu/Hr Input
300 - 300,000 Btu/Hr Input	960 - 1,200,000 Btu/Hr Input

7 - Heat Exchanger/Burner/Drip Pan Material (HE)

T - 409 Stainless Steel Heat Exchanger/Burner/Drip Pan

8 - Development Sequence Designation (DS)

F - Single Stage

M - 2-stage or Modulating

9 - Access Side (AS)

R - Right Hand

L - Left hand

10 - Air Temperature Rise (ATR)

H - High 60°-100°F

L - Low 20°-60°F

11 - Gas Type (GT)

N - Natural with ignition controller

P - Propane with ignition controller

12 - Gas Valve (GV)

1 - Single Stage

2 - Two Stage

4 - Electronic Modulation

7 - Electronic Modulation 0-10 Vdc External Input

9 - Electronic Modulation with Modine Control System

13 - Additional Safety Switches (SS)

0 - No Switches (Standard)

3 - High and Low Gas Pressure Switch (Premium)

14 - Supply Voltage (SV)

A - 115/60/1

B - 208/60/1

C - 230/60/1

D - 208/60/3

E - 230/60/3

F - 460/60/3

G - 575/60/3

15 - Transformer (TR)

1 - 40 VA

2 - 75 VA

3 - 150 VA

4 - 250 VA

0 - None

16 - Blower Size & Bearing Type (BB)

C - 9-9 Spider Bearings

D - 9-9 Pillow Block Bearings

E - 12-12 Spider Bearings

F - 12-12 Pillow Block Bearings

G - 15-15 Spider Bearings

H - 15-15 Pillow Block Bearings

I - 18-18 Spider Bearings under 15 Hp

J - 18-18 Pillow Block Bearings under 15 Hp

K - 18-18 Pillow Block Bearings under 15 Hp & up

L - 20-18 Pillow Block Bearings

17 - Motor Horsepower (HP)

A - 1/3 Hp

B - 1/2 Hp

C - 3/4 Hp

D - 1 Hp

E - 1-1/2 Hp

F - 2 Hp

G - 3 Hp

H - 5 Hp

I - 7-1/2 Hp

J - 10 Hp

K - 15 Hp

V - 20 Hp

L - 1/3 Hp with Motor Starter

M - 1/2 Hp with Motor Starter

N - 3/4 Hp with Motor Starter

P - 1 Hp with Motor Starter

Q - 1-1/2 Hp with Motor Starter

R - 2 Hp Hp with Motor Starter

S - 3 Hp with Motor Starter

T - 5 Hp with Motor Starter

W - 7-1/2 Hp with Motor Starter

X - 10 Hp with Motor Starter

Y - 15 Hp with Motor Starter

Z - 20 Hp with Motor Starter

18 - Motor Type (MT)

1 - ODP

2 - ODP - High Eff.

5 - TE

6 - TE - High Eff.

19 - Sheave Arrangement (SA)

A-Z - (See Sheave Tables)

20, 21 - Air Control (AC)

AA - RA Opening

BA - FA Opening

CA - FA & RA Openings

DA - FA Dampers w/2 pos motor (No RA)

EA - FA & RA Dampers w/2 pos motor

GA - FA & RA Mod motor w/0-10 Vdc External Input

GC - FA & RA Mod motor w/Minimum Position (Factory Mounted)

GE - FA & RA Mod motor w/3 pos. damper (100% RA, Variable, 100% OA)

22 - Evaporative Cooling (EC)

0 - None

23 - Cooling Coil (CC)

0 - None

1 - Factory Installed Coil

As Modine Manufacturing Company has a continuous product improvement program, it reserves the right to change design and specifications without notice.



Modine Manufacturing Company

1500 DeKoven Avenue

Racine, WI 53403

Phone: 1.800.828.4328

www.modinehvac.com